

ASSEMBLY INSTRUCTIONS

1. Before installation, please read the Assembly Instruction carefully.
2. Please check whether the Parts and Hardware are consistent with the list.
3. It is normal for the sealed environment to smell, not a product quality problem.

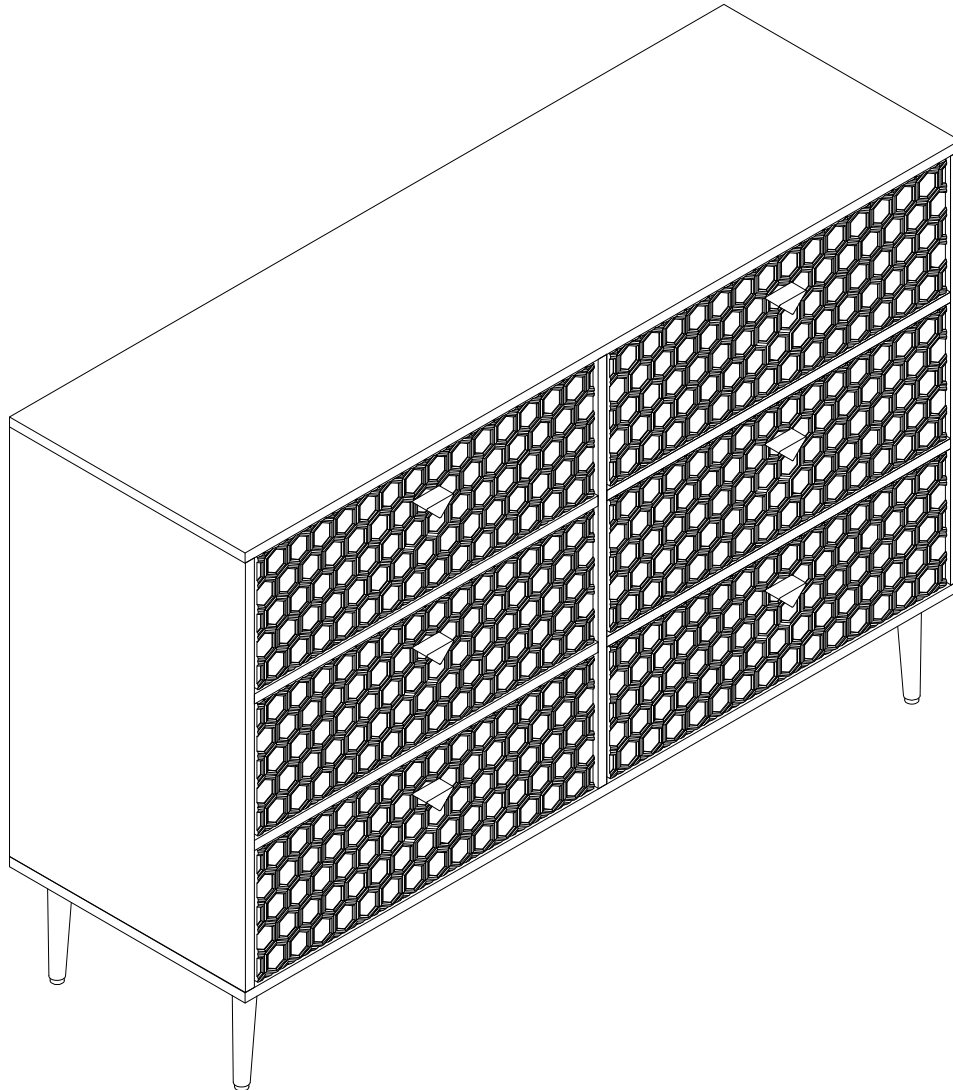

Phone number:

(909) 297-5794/ (323) 982-8955

service@boyelliving.com

Web: www.boyelliving.com

ASSEMBLY INSTRUCTIONS

Part List:

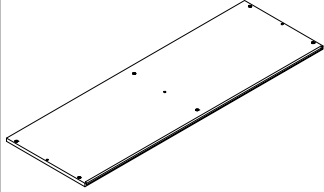
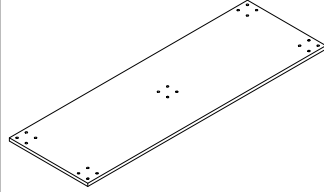
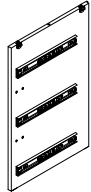
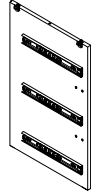
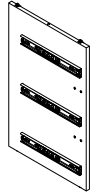
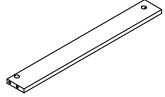
ITEM	DESCRIPTION	PART	QTY
1	Top panel		1
2	Bottom panel		1
3	Left side panel		1
4	Right side panel		1
5	Partition Panel		1
6	Left crossbeam		2

Part List:

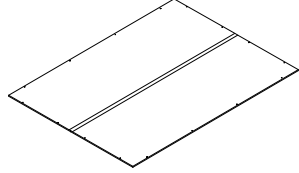
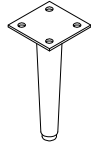
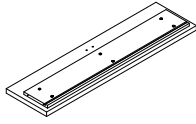
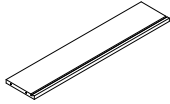
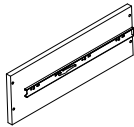
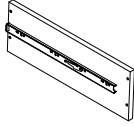
ITEM	DESCRIPTION	PART	QTY
7	Back panel		1
8	Leg		5
9	drawer front		6
10	Drawer back		6
11	Drawer Left Side		6
12	Drawer Right Side		6

ASSEMBLY INSTRUCTIONS

Part List:

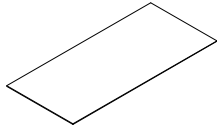



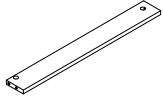

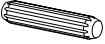

ITEM	DESCRIPTION	PART	QTY
13	Drawer bottom		6

Part List:







ITEM	DESCRIPTION	PART	QTY
14	Right crossbeam		2

ASSEMBLY INSTRUCTION

Hardware List:

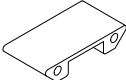
ITEM	DESCRIPTION	PART	QTY
A	Wooden dowel	 Φ8*30mm	14
B	Short bolt	 Φ1/4"*1/2"	20
C	Cam Bolt		8
D	Cam Lock		8
E	Allen wrench		1
F	Round head screw	 Φ3*16mm	22
G	Safety wall strap		2
H	Plastic anchor		2

Hardware List:

ITEM	DESCRIPTION	PART	QTY
I	Mounting screw	 Φ4*38mm	2
J	Flat Head screw	 Φ4*30mm	48
K	Handle		6
L	Bolt	 Φ5/32"*1-1/8"	12
M	Washer		2
N	Long bolt	 Φ1/4"*1"	6

- * Required screwdriver & mallet, not included.
- * Before discarding packing materials, please check to make sure that all parts and hardware is present.
- * Two people needed for assembly.
- * Please follow the instructions closely; do not over tighten screws or bolts unless instructed.
- * After a few days from initial assembly, the product may have acclimated to the new environment. Please retighten the hardware.

Guideline For Assembling of Plastic Lock

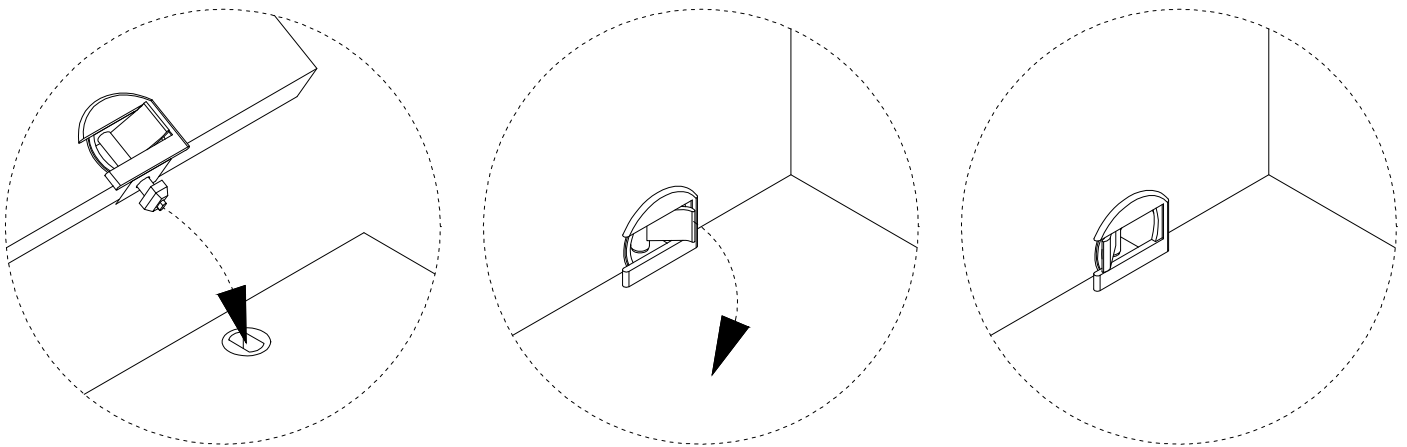

ASSEMBLY INSTRUCTION

Guideline For Assembling of Cam Lock(A & B)

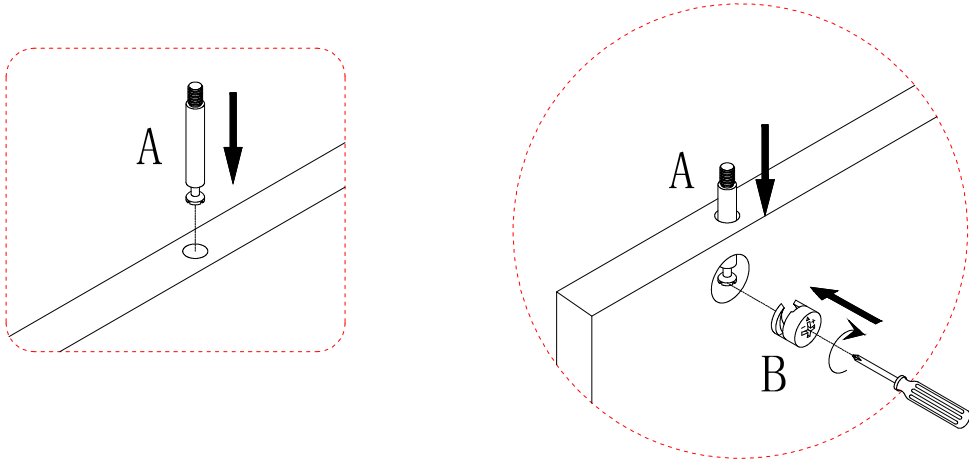

Screw camlock bolt (A) to wood part.
Do not assemble camlock (B) unless instructed.
To assemble camlock (B), ensure long side of the + is facing the bolt (A) before inserting into hole.

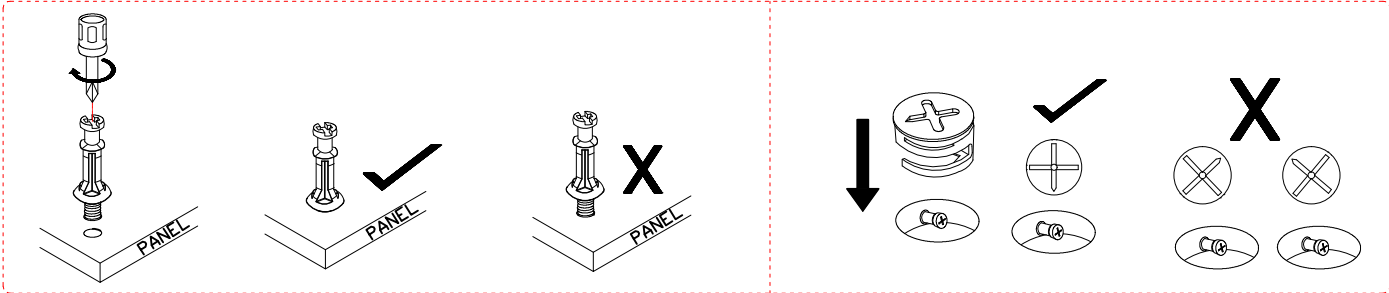



ASSEMBLY INSTRUCTION

STEP 1

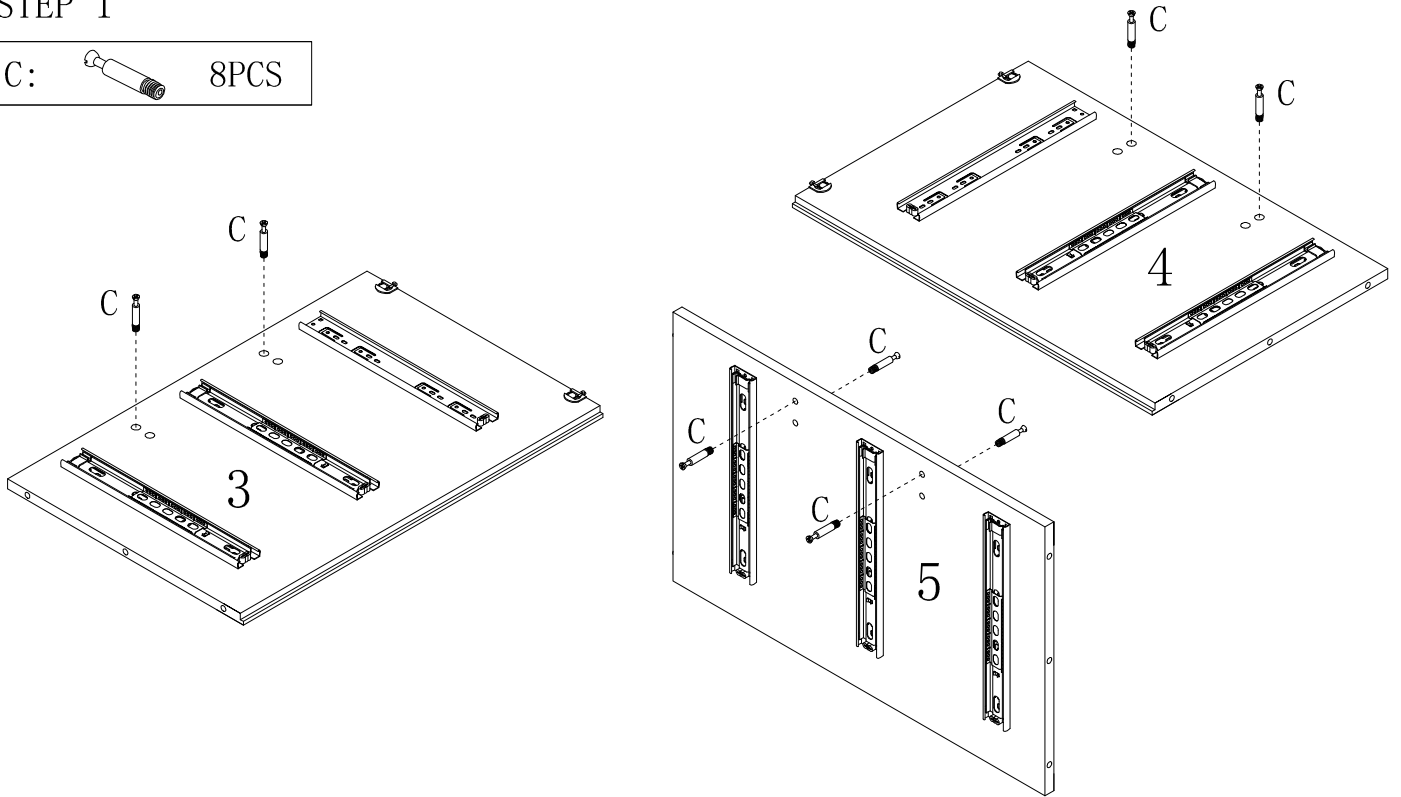
C:  8PCS



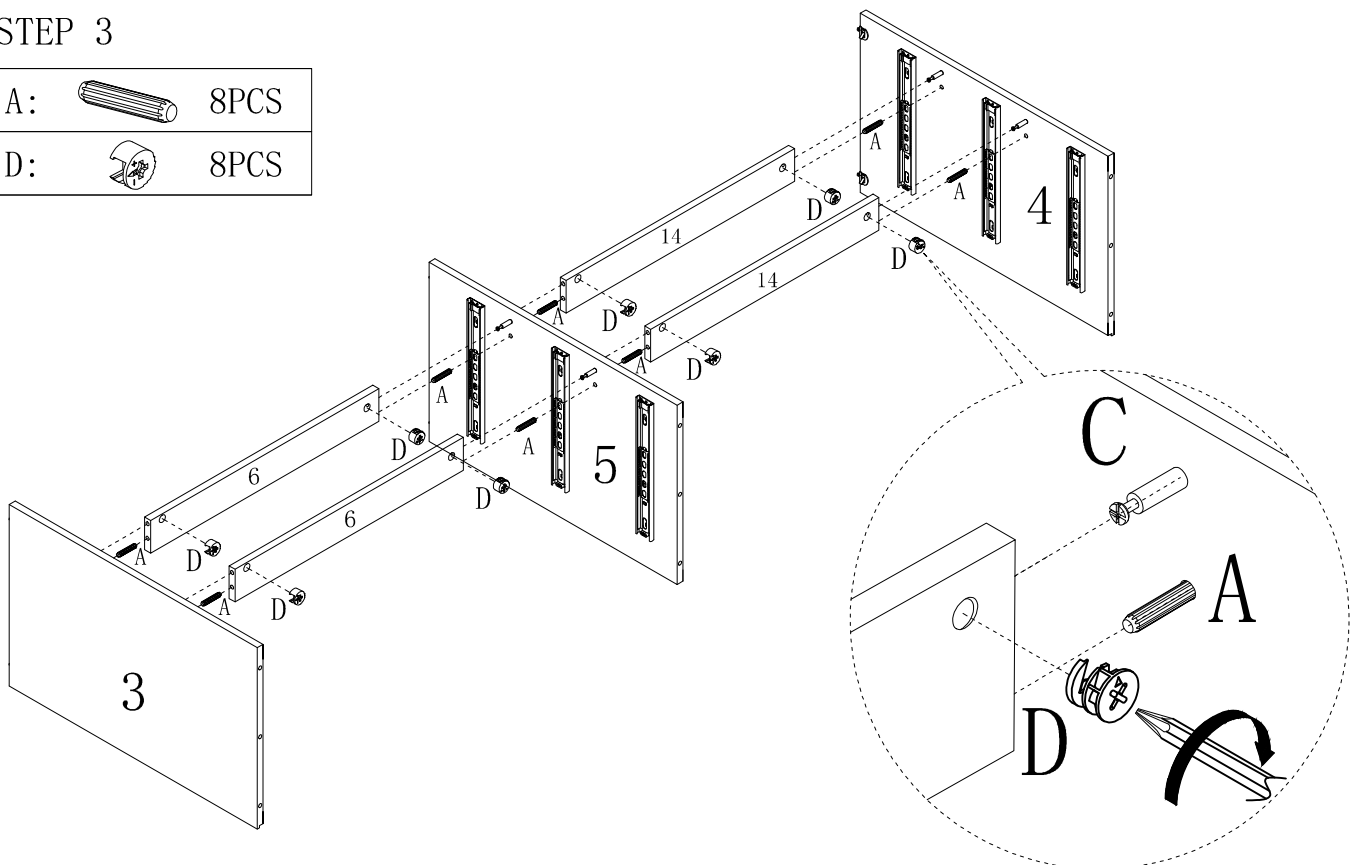

STEP 3

A:  8PCS
D:  8PCS



ASSEMBLY INSTRUCTION

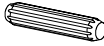

STEP 2

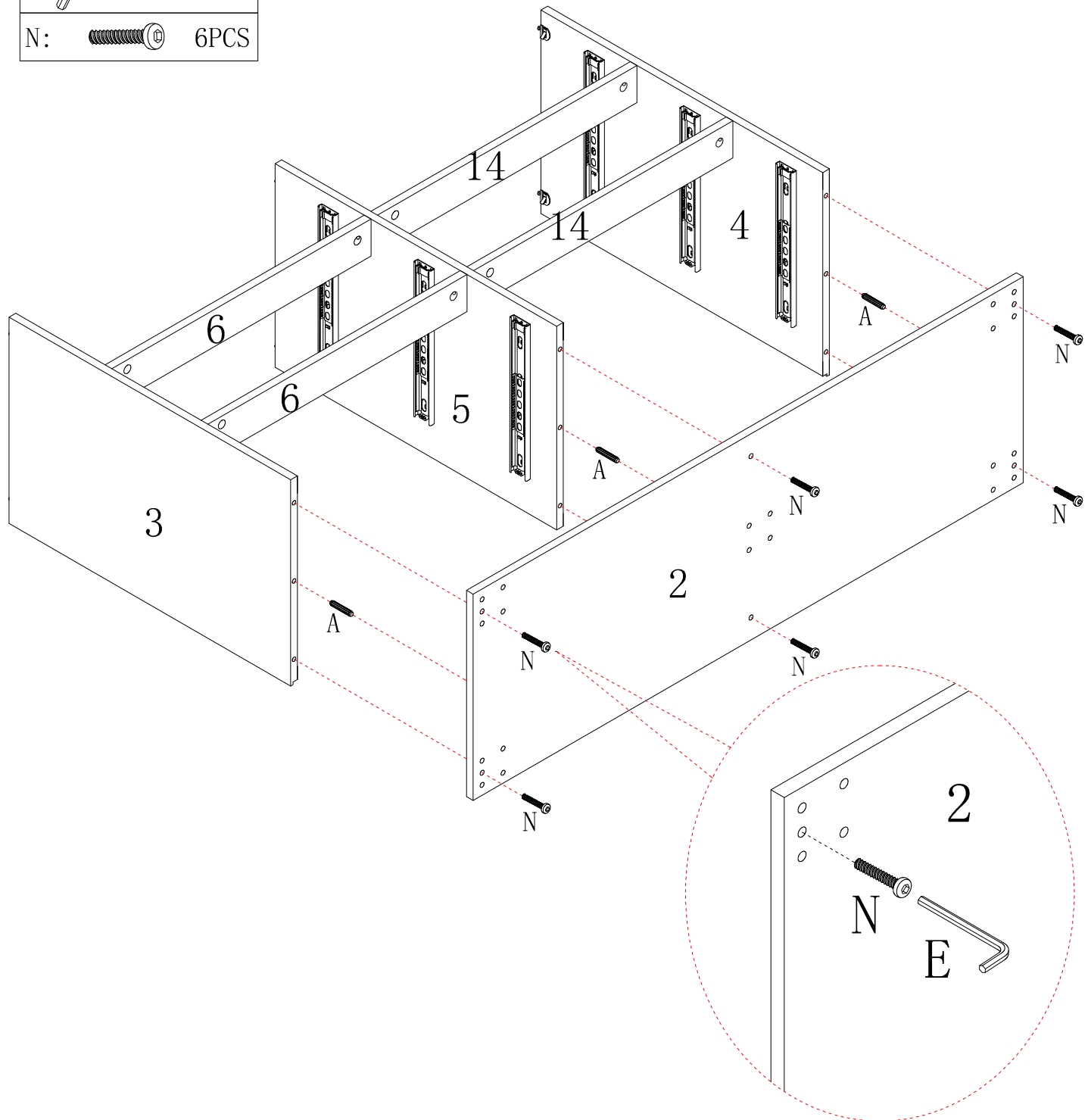
A:		3PCS
E:		1PC
N:		6PCS



ASSEMBLY INSTRUCTION

STEP 3

B:		20PCS
E:		1PC

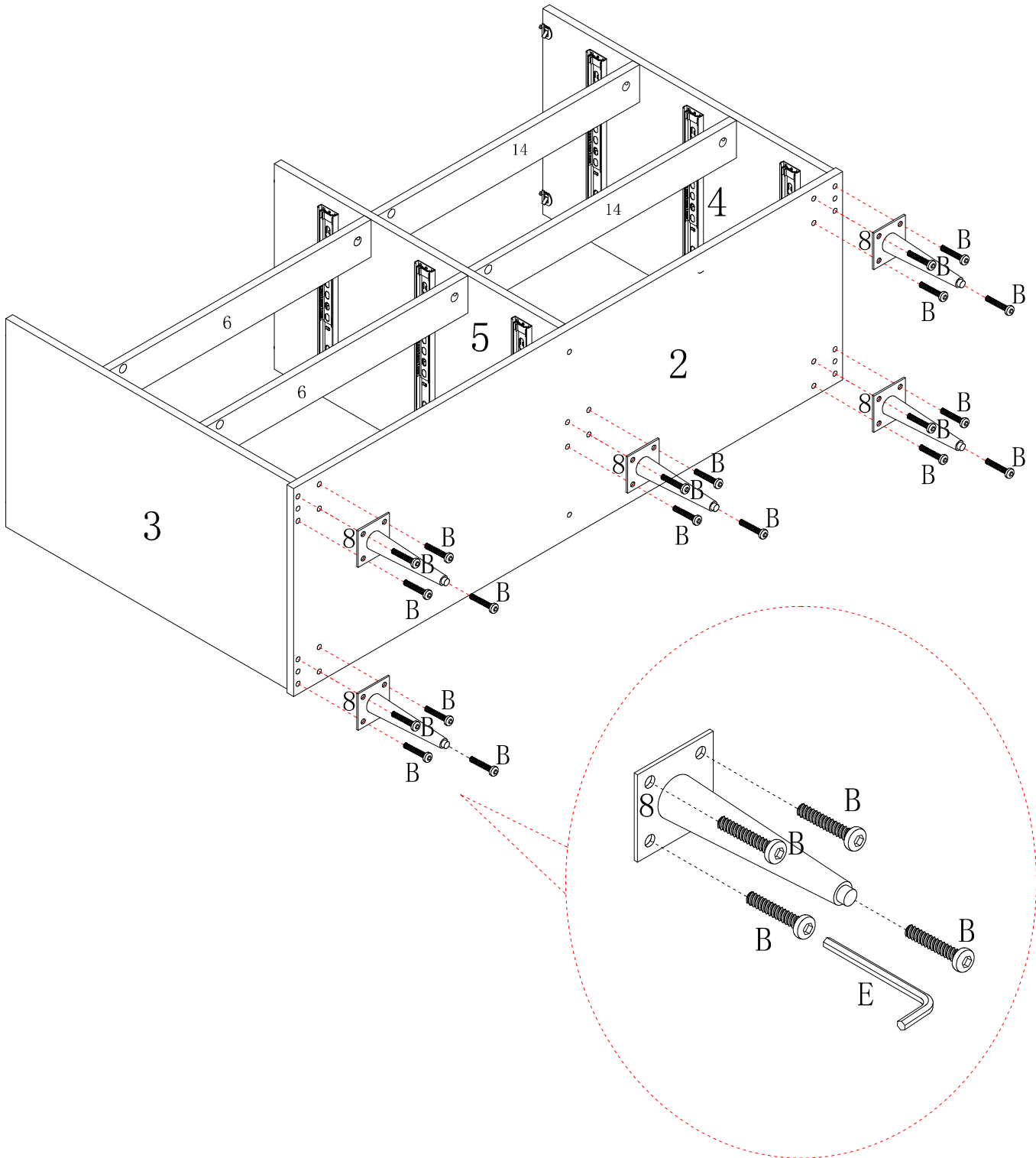

ASSEMBLY INSTRUCTION

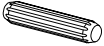

STEP 4

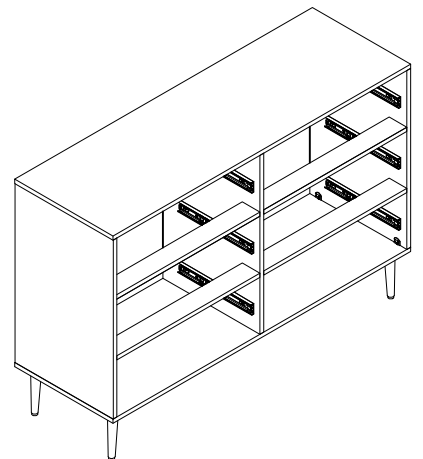
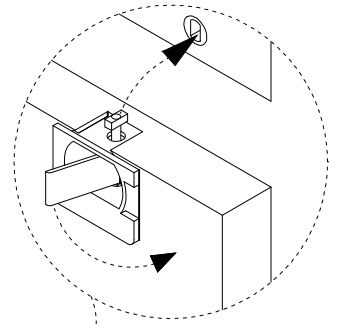
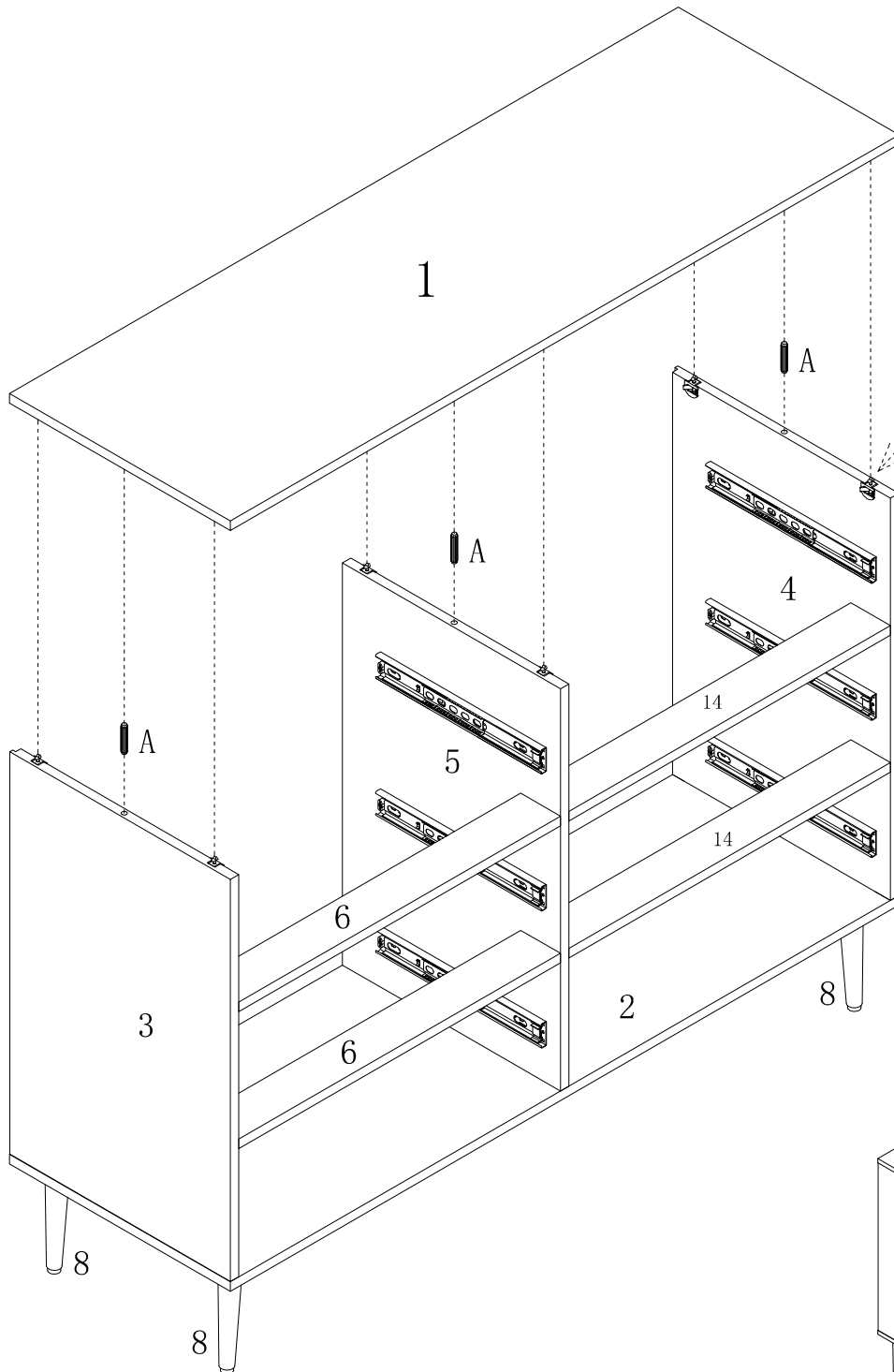
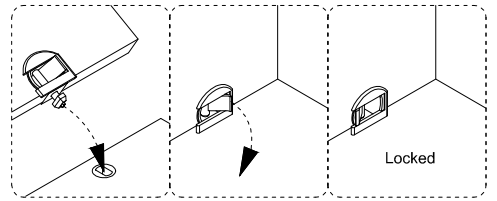
A:  3PCS



ASSEMBLY INSTRUCTION

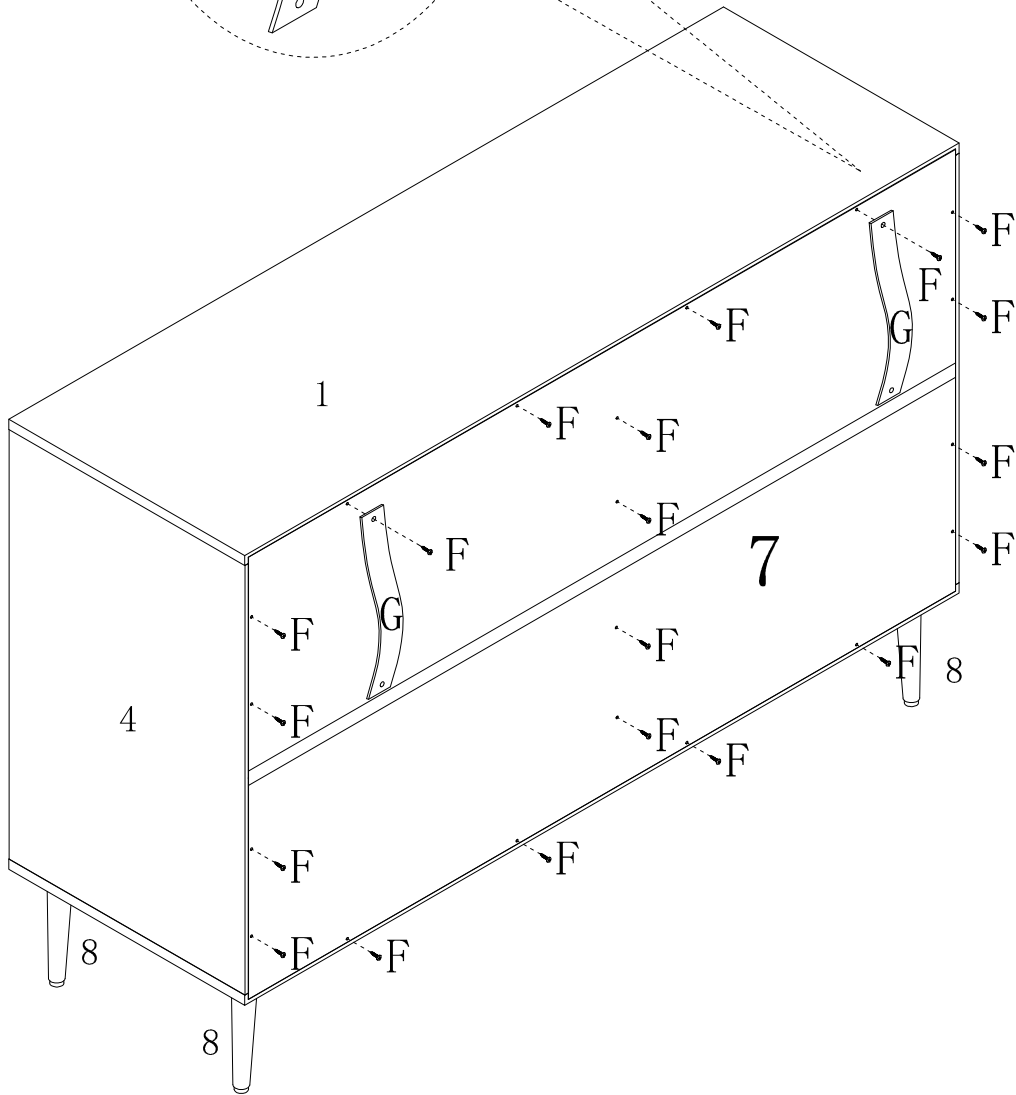
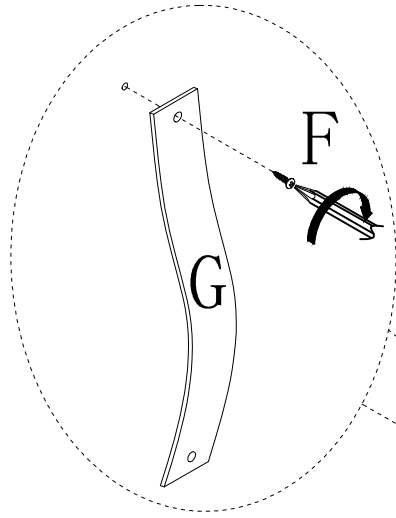

STEP 5

F:		20PCS
G:		2PCS



ASSEMBLY INSTRUCTION

STEP 6

J:		48PCS
K:		6PCS
L:		12PCS

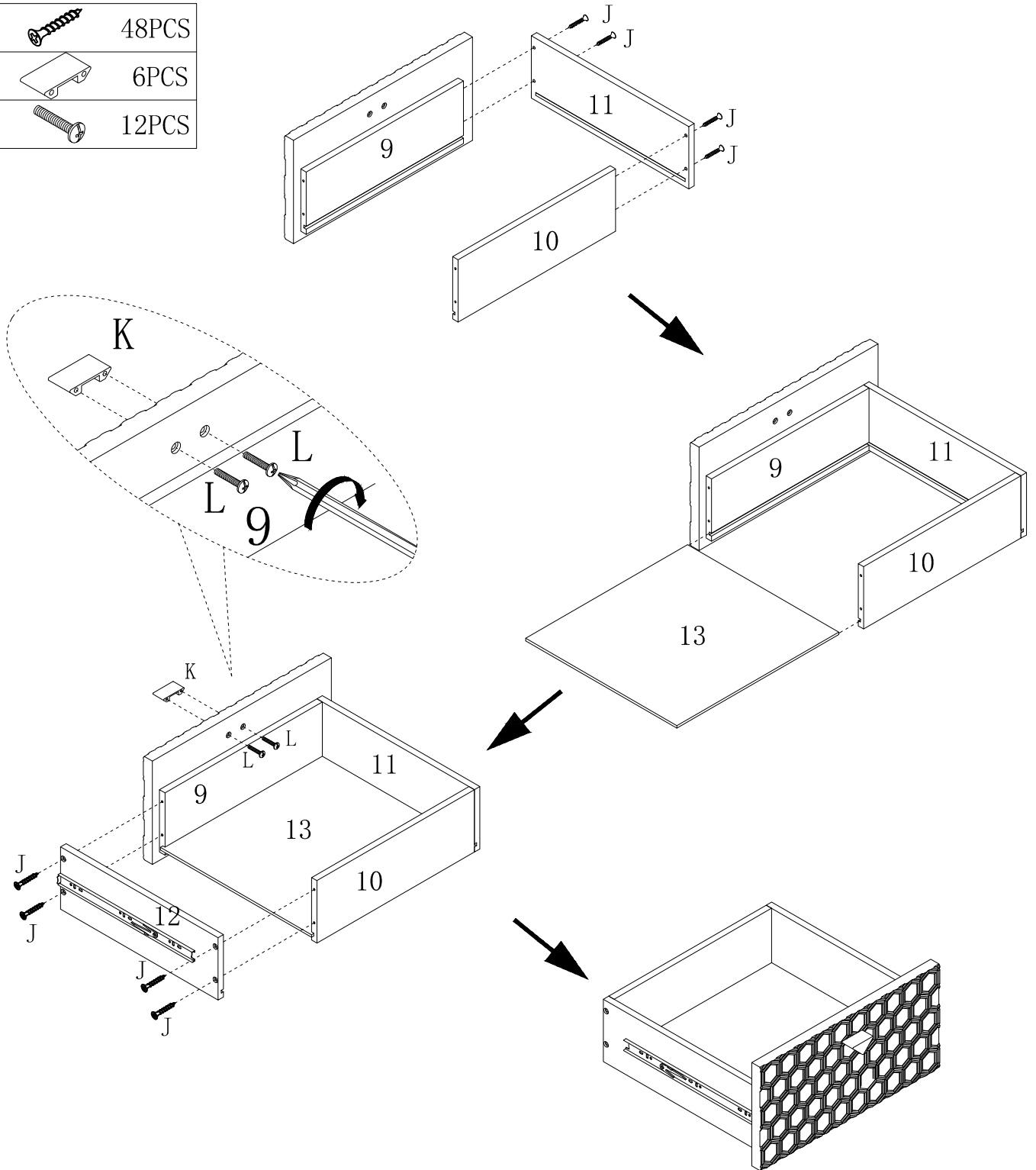

6 drawers are assembled in the same way

ASSEMBLY INSTRUCTION

STEP 7

Note: Place the slidable part to the front position before sliding in

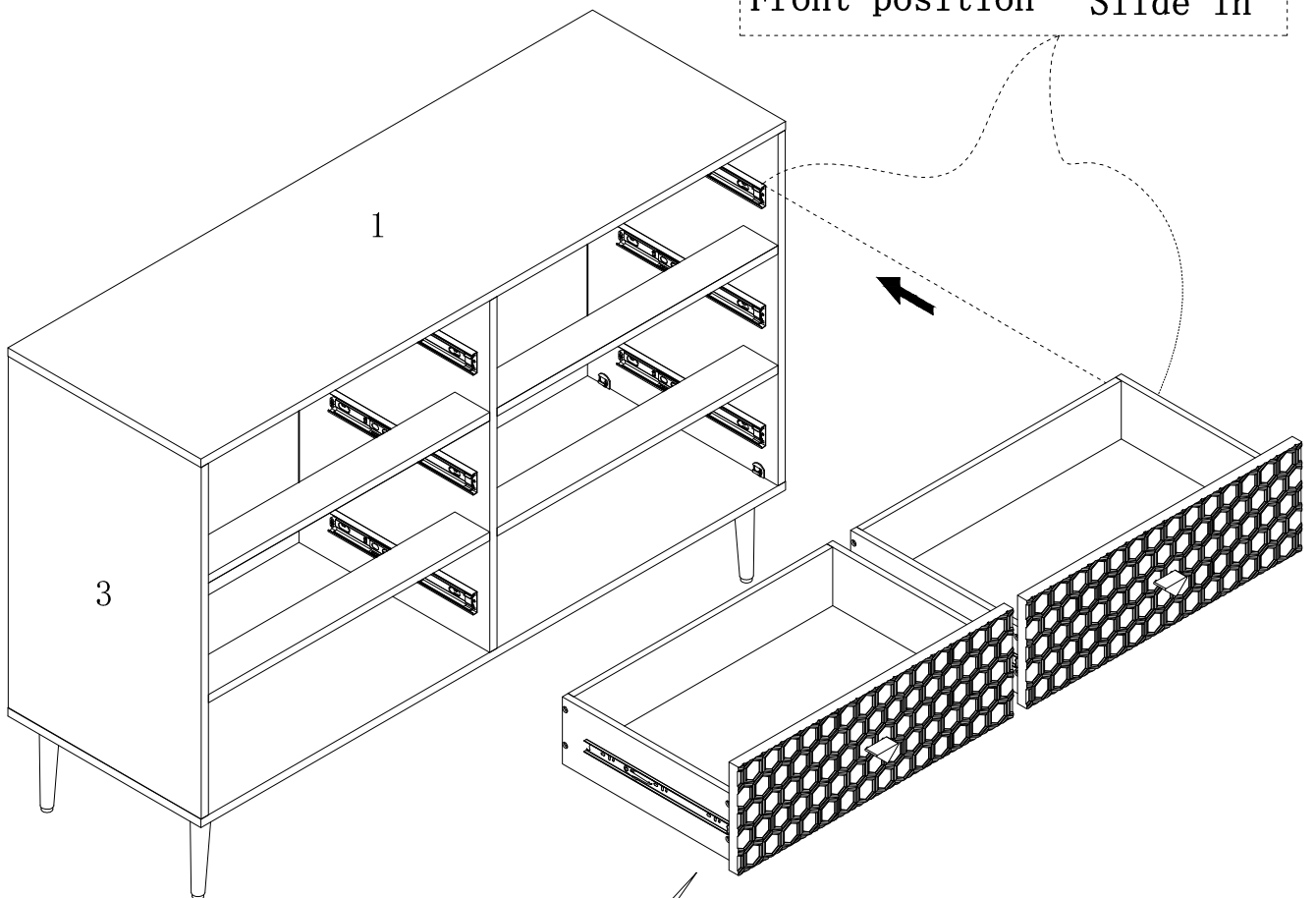
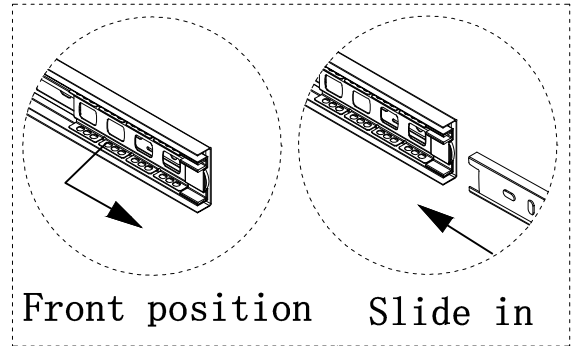

Reminder: If the front and both ends of the drawer are tilted, do not use force, You can refer to the above steps to smoothly insert the slide rail.

STEP 8

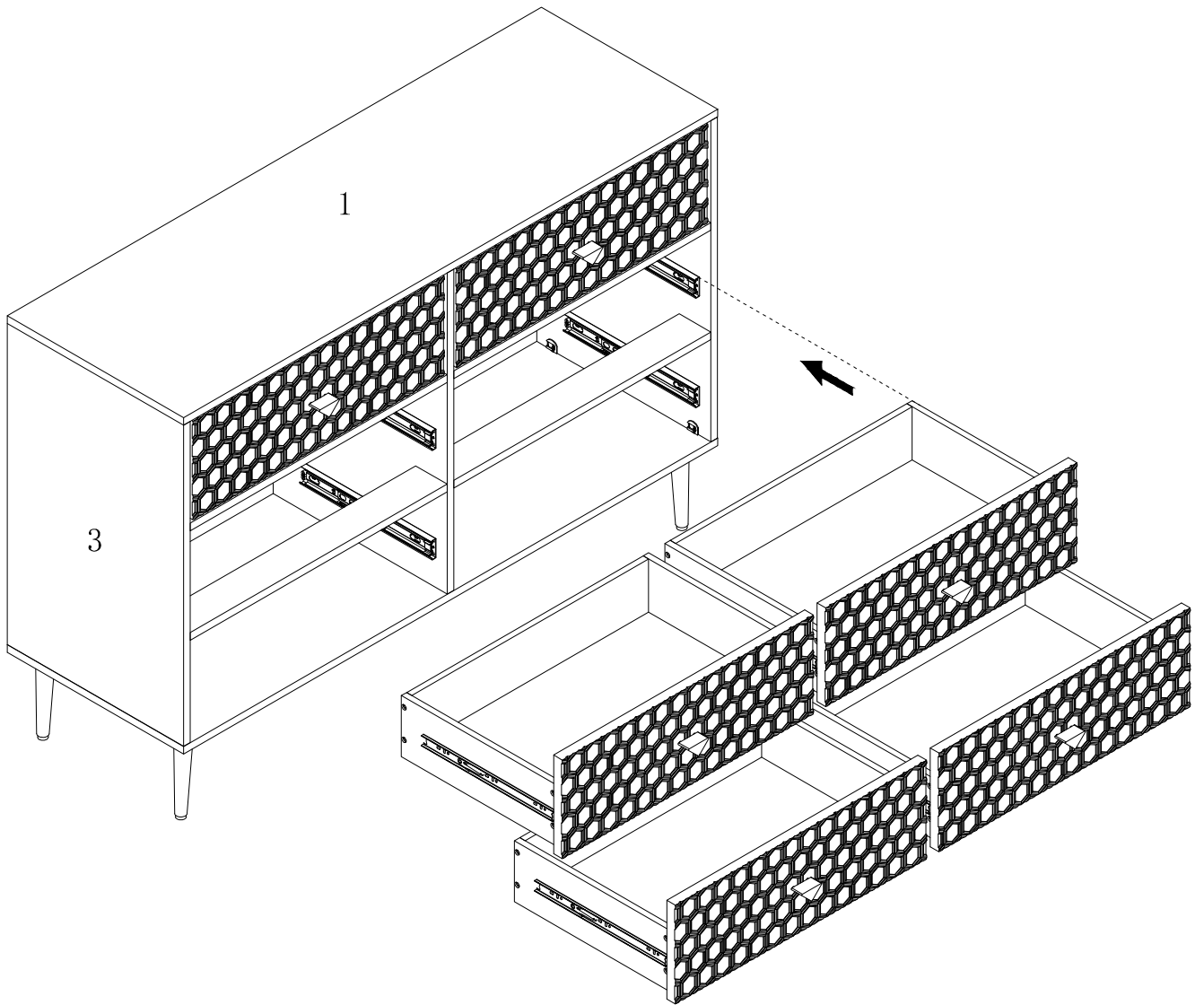

ASSEMBLY INSTRUCTION

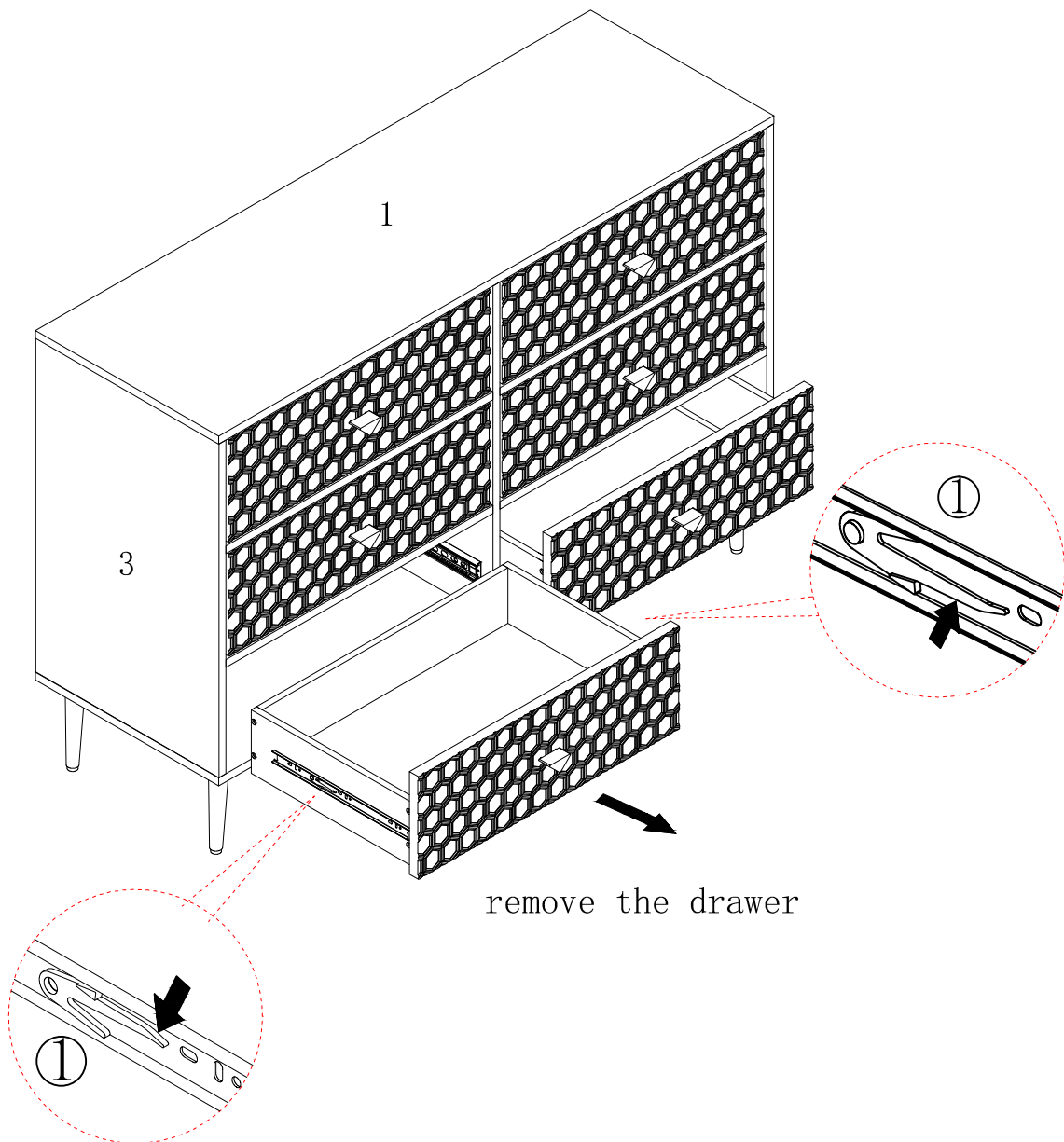

STEP 9



To remove the drawer. lift up on the left side buckle and press down on the right side buckle, operating both left and right at the same time, and move outward to remove it.

ASSEMBLY INSTRUCTION

STEP 10

H:		2PCS
I:		2PCS
M:		2PCS

For safety reasons,
it is recommended to install
safety wall strap to fix the item.

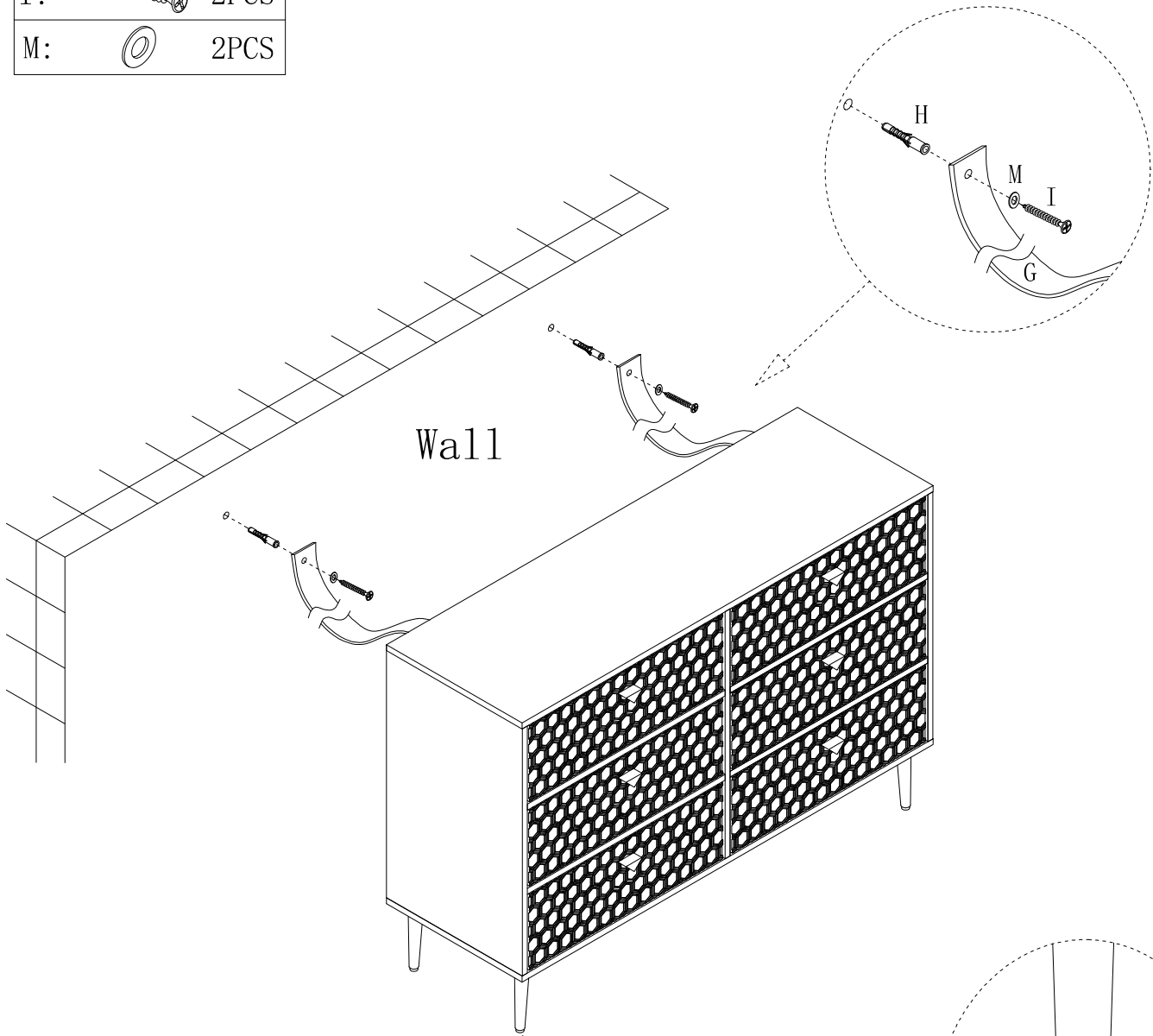

After installation, adjust the
adjustable foot to keep the cabinet
balanced and align the door.

