

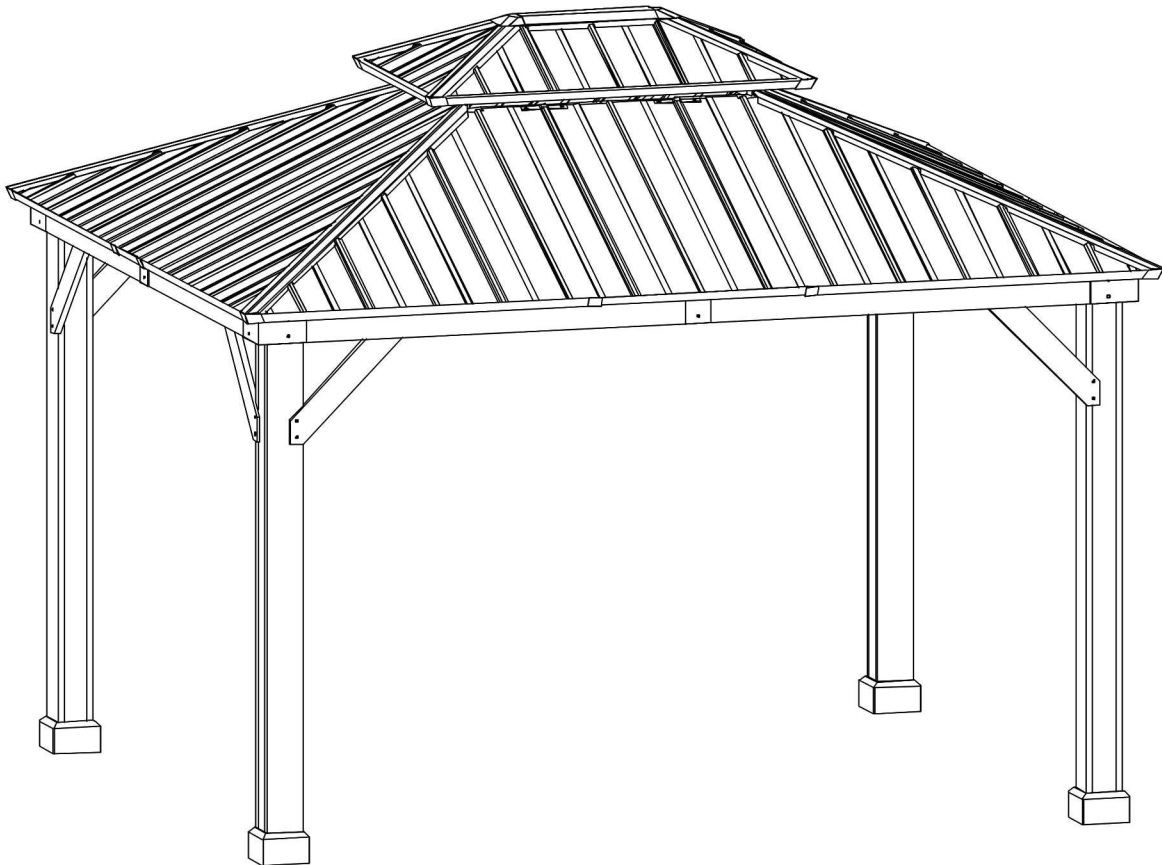

MONDAWE

Website: www.mondawe.com
Customer Service: service@mondawe.com
Phone: 888-328-5111

Site Internet : www.mondawe.com
Email de Service Client : service@mondawe.com
Numéro de Téléphone : 888-328-5111



4MO1012140

Assembly Instruction

Instruction de montage

10x12ft Cedar Framed Galvanized Steel Double Roof Gazebo

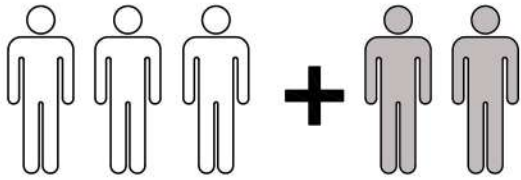

EN: Three or more people are required for assembly

FR: Trois personnes ou plus sont nécessaires pour l'assemblage

EN: The following tools are not included and needed for assembly

FR: Les outils suivants ne sont pas inclus et nécessaires pour l'assemblage

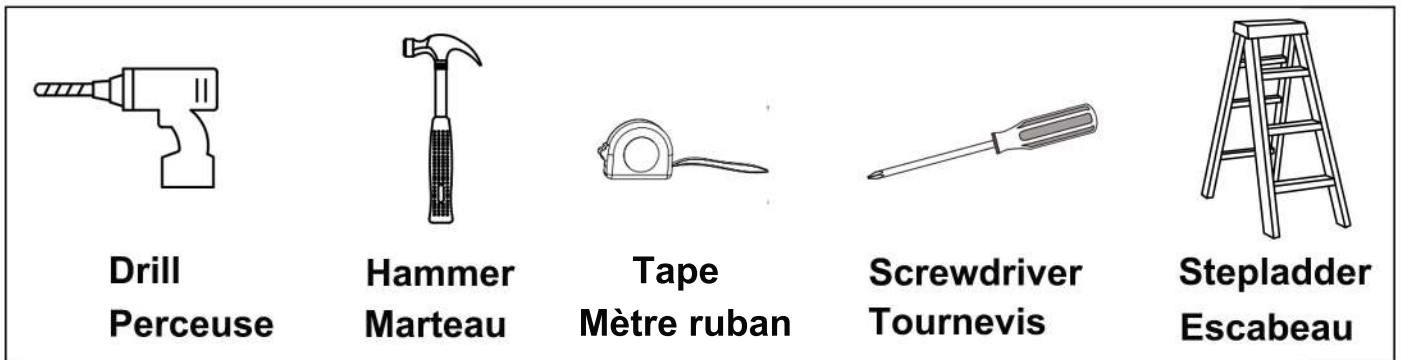

EN: Note:

1. The gazebo come with 4 carton boxes.
2. Wearing protective gloves is recommended.
3. Do not fully tighten screws prior to complete assembly.







FR: Avis:

1. Le gazebo est livré avec 4 boîtes en carton.
2. Le port de gants de protection est recommandé.
3. Ne serrez pas complètement les vis avant de terminer l'assemblage.

EN









Before You Start

-  Please read all instructions carefully.
-  Retain instructions for future reference.
-  Separate and count all parts and hardware.
-  Read through each step carefully and follow the proper order.
-  We recommend that, where possible, all items are assembled near to the area in which they will be placed in use, to avoid moving the product unnecessarily once assembled.
-  Always place the product on a flat, steady and stable surface.
-  Keep all small parts and packaging materials for this product away from babies and children as they potentially pose a serious choking hazard.

FR



Avant de Commencer

-  Veuillez lire attentivement toutes les instructions.
-  Conservez les instructions pour vous y référer ultérieurement.
-  Vérifiez toutes les pièces et les accessoires.
-  Lisez attentivement chaque étape et suivez l'ordre correct.
-  Nous recommandons que, dans la mesure du possible, tous les produits soient assemblés à proximité de la zone où ils seront utilisés, afin d'éviter tout déplacement inutile du produit une fois assemblé.
-  Placez toujours le produit sur une surface plane et stable.
-  Conservez toutes les petites pièces de ce produit et les matériaux d'emballage hors de portée des bébés et des enfants, car ils pourraient présenter un risque d'étouffement.

PARTS LIST (Carton Box -1)

08

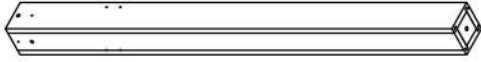

Post

2PCS

01



Long side outer left beam

2PCS

02



Long side outer right beam

2PCS

PARTS LIST (Carton Box -2)

08



Post

2PCS

03



Short side outer left beam

2PCS



04



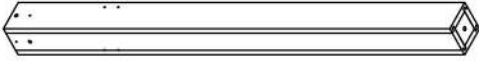

Short side outer right beam

2PCS





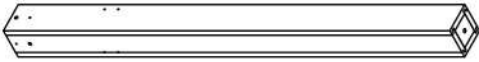













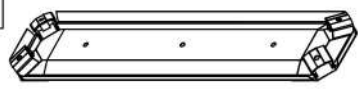
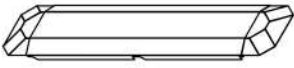

Liste des pièces(Boîte en carton 1)

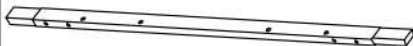
08  Poteau	01  Poutre extérieur gauche de côté long
2	2
02  Poutre droit extérieur du côté long	
2	



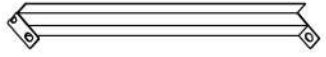



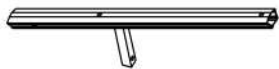
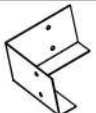



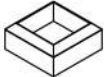







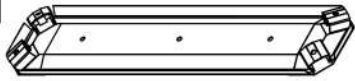

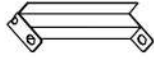

Liste des pièces(Boîte en carton 2)

08  Poteau	03  Poutre extérieur gauche du côté court
2	2
04  Poutre droit extérieur du côté court	
2	

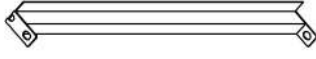









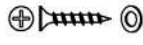













PARTS LIST (Carton Box -3)

G1  Big roof slant beam 4PCS	09  Base cover 4PCS	H1  Big roof middle beam 8PCS
K7  Big roof left blocking bar 4PCS	K8  Big roof right blocking bar 4PCS	Q1  Small roof short tube 2PCS
K1  Big roof short middle tube 4PCS	S2  Long slant beam cover 4PCS	S1  Small roof slant beam cover 4PCS
M1  Small roof connector 1PC	P1  Small roof cover 1PC	I1  Big roof short side tube 2PCS
K3  Big roof short tube 8PCS	F8  Middle cover 4PCS	K5  Short side middle blocking bar 2PCS
I2  Big roof long side tube 2PCS	Q2  Small roof long tube 2PCS	E1  Long curtain bar 4PCS
E2  Short curtain bar 4PCS	K6  Long side middle blocking bar 2PCS	B6  Base 4PCS
G5  Slant beam bottom connector 4PCS	K2  Big roof long middle tube 4PCS	K4  Big roof long tube 8PCS
L1  Small roof slant beam 4PCS	F9  Conner cover 4PCS	











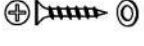

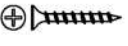









Liste des pièces(Boîte en carton 3)

G1  Poutre inclinée de grand toit 4	O9  Couvercle de base 4	H1  Poutre centrale de grand toit 8
K7  Barre de blocage gauche de grand toit 4	K8  Barre de blocage droite du grand toit 4	Q1  Tube court de petit toit 2
K1  Court tube central de grand toit 4	S2  Couverture d'une longue poutre inclinée 4	S1  Couverture de poutre inclinée de petit toit 4
M1  Connecteur de petit toit 1	P1  Couverture de petit toit 1	I1  Tube latéral court de grand toit 2
K3  Tube court de grand toit 8	F8  Couvercle central 4	K5  Barre de blocage centrale du côté court 2
I2  Long tube latéral de grand toit 2	Q2  Long tube de petit toit 2	E1  Barre à rideau longue 4
E2  Barre à rideau court 4	K6  Barre de blocage centrale de côté long 2	B6  Base 4
G5  Connecteur inférieur de poutre inclinée 4	K2  Long tube central de grand toit 4	K4  Long tube de grand toit 8
L1  Poutre inclinée de petit toit 4	F9  Couvercle d'angle 4	

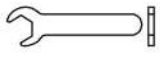



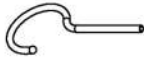

HARDWARE LIST (Carton Box -3)

AA	M10X205	BB	M5X25	CC	M10X80
					
Outer Hex head bolt & Washer		Self-tapping screw & Washer		Self-tapping screw & Washer	
8PCS		48+5PCS		8PCS	
DD	M8X35	EE	M5X40	FF	M8X25
					
Self-tapping screw & Washer		Self-tapping screw		Inner Hex head screw & Washer	
32+3PCS		92+9PCS		24+2PCS	
GG	M6	HH	M6X15	II	M6X15
					
Nut & Washer		Inner Hex head screw & Washer		Outer Hex head bolt & Washer	
14+2PCS		52+5PCS		16+2PCS	
JJ	M6	KK	M6X55	MM	M10
					
Washer		Inner Hex head screw & Nut		Nut	
28+3PCS		12+2PCS		8+1PCS	
PP	M8X10	TT	M6X15	UU	ø6x200
					
T-Nut		Inner Hex head screw & Washer		Stake	
24+3PCS		76+8PCS		16PCS	
VV	M3	Z1	M6	Z2	M6
					
Drill		Wrench		Screwdriver set head	
2PCS		2PCS		1PC	
Z3	M10	Z4	M8	Z5	M6
					
Wrench		Allen key		Allen key	
2PCS		2PCS		2PCS	
Z6	M6	Z7	M8	R1	
					
Hex screwdriver head		Hex screwdriver head		Press panel	
1PC		1PC		28PCS	
N1					
					
Hook					
1PC					

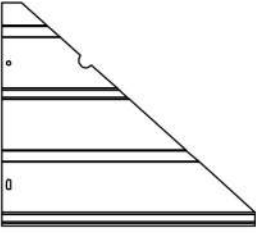
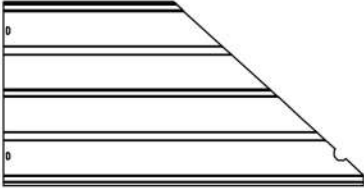
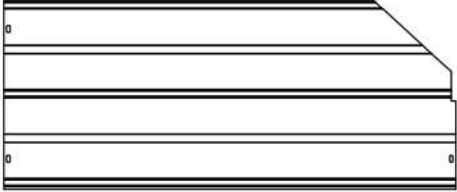
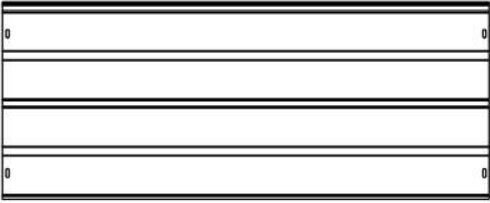
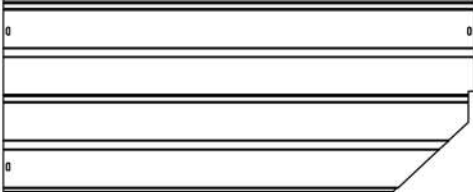
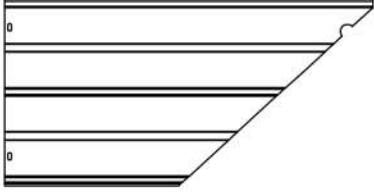
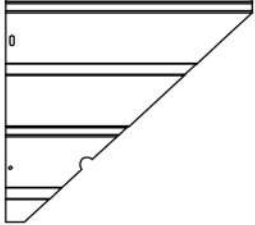
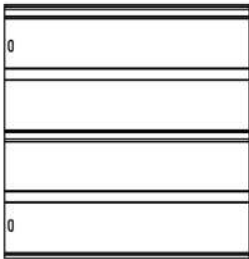

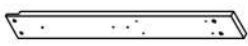



Liste des quincaillerie(Boîte en carton 3)

AA	M10X205	BB	M5X25	CC	M10X80
	Boulon de tête hexagonal extérieur & Rondelle		Vis taraudeuse & Rondelle		Vis taraudeuse & Rondelle
8		48+5		8	
DD	M8X35	EE	M5X40	FF	M8X25
	Vis taraudeuse & Rondelle		Vis taraudeuse & Rondelle		Vis à tête hexagonale interne & Rondelle
32+3		92+9		24+2	
GG	M6	HH	M6X15	II	M6X15
	Écrou & Rondelle		Vis à tête hexagonale interne & Rondelle		Boulon de tête hexagonal extérieur&Rondelle
14+2		52+5		16+2	
JJ	M6	KK	M6X55	MM	M10
	Rondelle		Vis à tête hexagonale interne & Écrou		Écrou
28+3		12+2		8+1	
PP	M8X10	TT	M6X15	UU	ø6x200
	T-Écrou		Vis à tête hexagonale interne & Rondelle		Piquet
24+3		76+8		16	
VV	M3	Z1	M6	Z2	M6
	Foret		Clef de tête hexagonal extérieur		Tête de jeu de tournevis
2		2		1	
Z3	M10	Z4	M8	Z5	M6
	Clef de tête hexagonal extérieur		Clef de tête hexagonal intérieur		Clef de tête hexagonal intérieur
2		2		2	
Z6	M6	Z7	M8	R1	
	Tête de tournevis hexagonale		Tête de tournevis hexagonale		Panneau de presse
1		1		28	
N1					
	Crochet				
1					

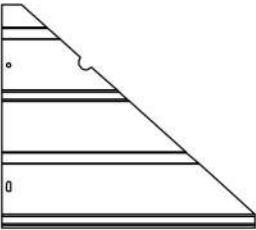
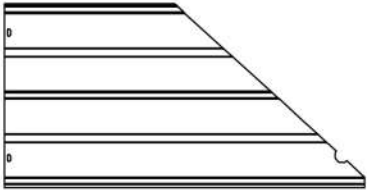
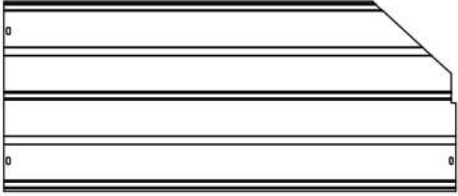
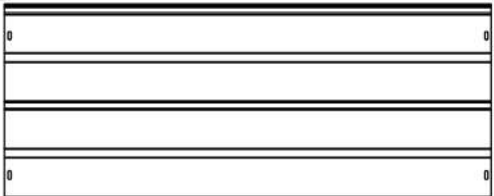
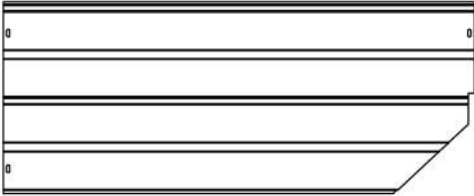
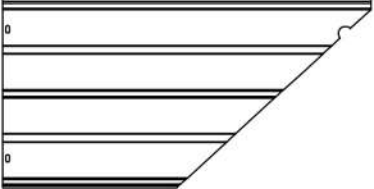
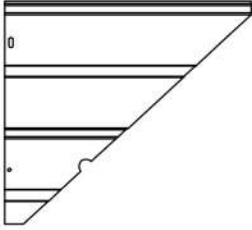
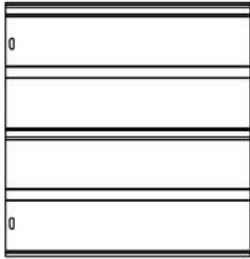
PARTS LIST (Carton Box -4)

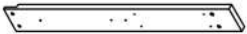
<p>T1</p>  <p style="text-align: center;">Left small cover plate</p> <p style="text-align: center;">8PCS</p>	<p>T2</p>  <p style="text-align: center;">Big roof left cover plate</p> <p style="text-align: center;">4PCS</p>
<p>T3</p>  <p style="text-align: center;">Big roof left middle big cover plate</p> <p style="text-align: center;">4PCS</p>	<p>T4</p>  <p style="text-align: center;">Big roof middle big cover plate</p> <p style="text-align: center;">2PCS</p>
<p>T5</p>  <p style="text-align: center;">Big roof right middle big cover plate</p> <p style="text-align: center;">4PCS</p>	<p>T6</p>  <p style="text-align: center;">Big roof right cover plate</p> <p style="text-align: center;">4PCS</p>
<p>T7</p>  <p style="text-align: center;">Right small cover plate</p> <p style="text-align: center;">8PCS</p>	<p>T8</p>  <p style="text-align: center;">Small roof middle cover plate</p> <p style="text-align: center;">2PCS</p>
<p>05</p>  <p style="text-align: center;">Inner middle beam</p> <p style="text-align: center;">4PCS</p>	<p>06</p>  <p style="text-align: center;">Long side inner short beam</p> <p style="text-align: center;">4PCS</p>
<p>07</p>  <p style="text-align: center;">Short side inner short beam</p> <p style="text-align: center;">4PCS</p>	<p>10</p>  <p style="text-align: center;">Left slant support</p> <p style="text-align: center;">4PCS</p>
<p>11</p>  <p style="text-align: center;">Right slant support</p> <p style="text-align: center;">4PCS</p>	

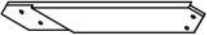
Liste des pièces(Boîte en carton 4)

<p>T1</p>  <p>Petite plaque de couverture gauche</p>	<p>T2</p>  <p>Plaque de couverture gauche de grand toit</p>
<p>8</p>	<p>4</p>
<p>T3</p>  <p>Milieu gauche grande plaque de couverture de grand toit</p>	<p>T4</p>  <p>Moyenne grande plaque de couverture de grand toit</p>
<p>4</p>	<p>2</p>
<p>T5</p>  <p>Milieu droit grande plaque de couverture de grand toit</p>	<p>T6</p>  <p>Plaque de couverture droite de grand toit</p>
<p>4</p>	<p>4</p>
<p>T7</p>  <p>Petite plaque de couverture droite</p>	<p>T8</p>  <p>Plaque de couverture centrale de petit toit</p>
<p>8</p>	<p>2</p>
<p>05</p>  <p>Poutre central intérieur</p>	<p>06</p>  <p>Poutre court intérieur de côté long</p>
<p>4</p>	<p>4</p>
<p>07</p>  <p>Poutre court intérieur de côté court</p>	<p>10</p>  <p>Support de gauche</p>
<p>4</p>	<p>4</p>
<p>11</p>  <p>Support côté droit</p>	
<p>4</p>	

Exploded Views

Vue éclatées

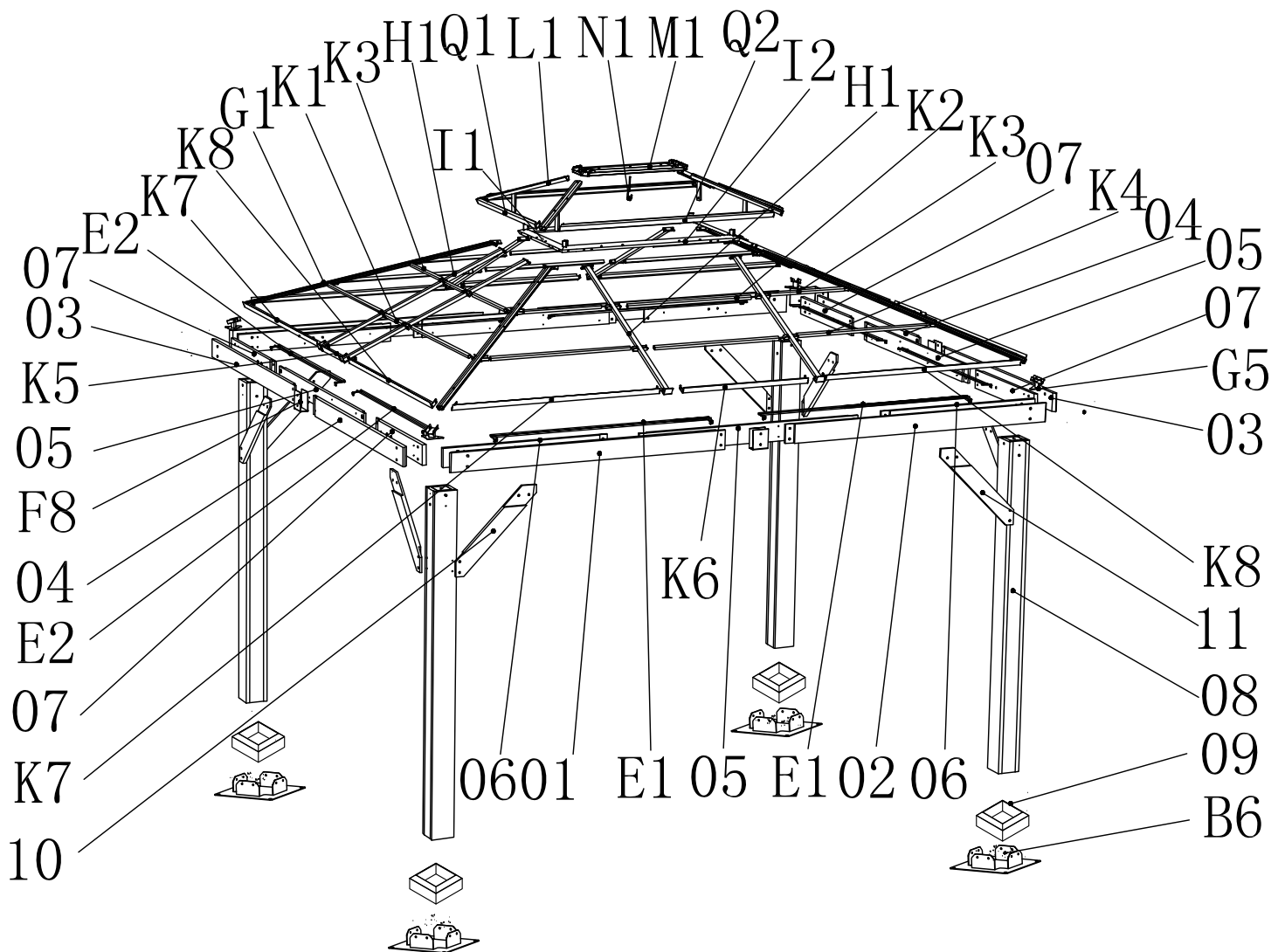
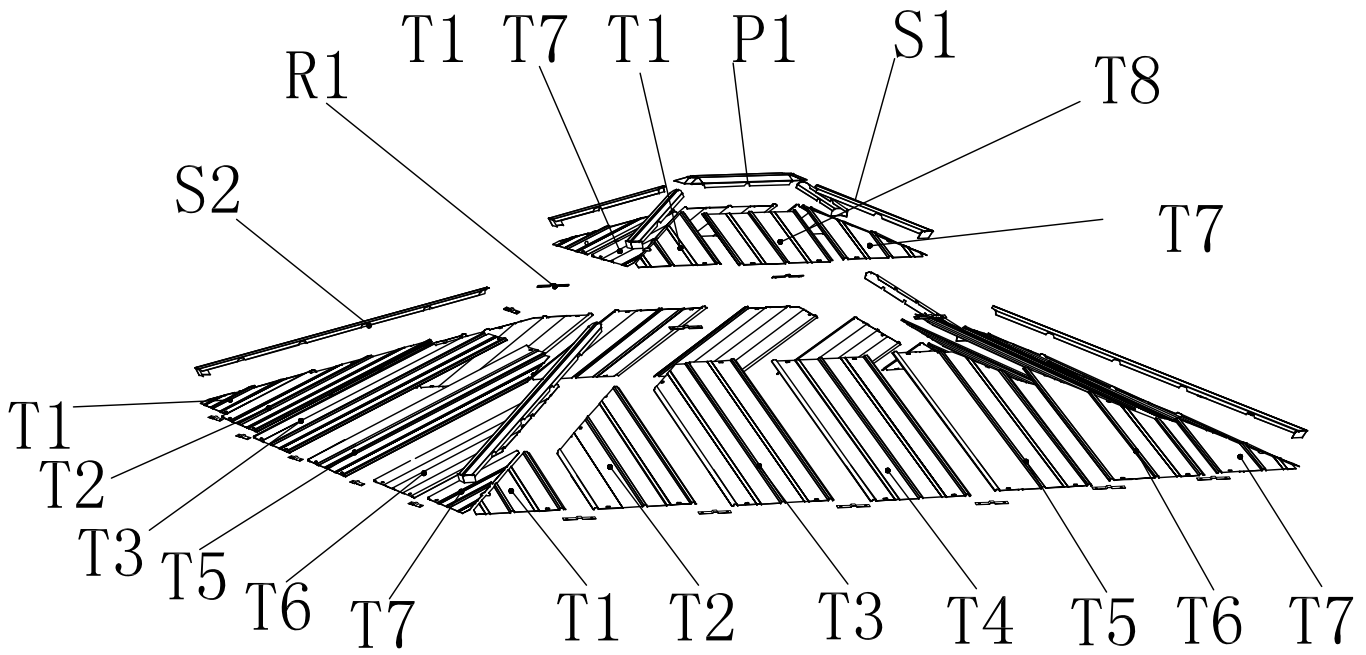

<1>



08 4X

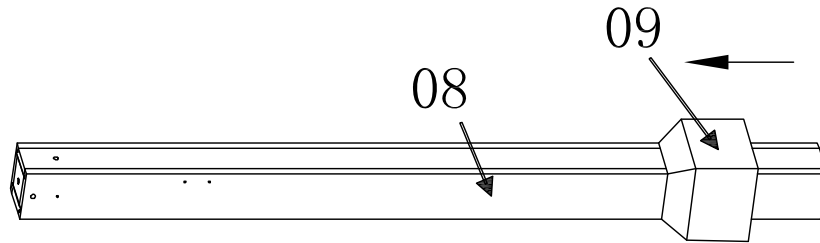

EN: Put base cover **09** through bottom of post **08**.

FR: Placez le couvercle de base **09** au bas du poteau **08**.



09 4X

<2>

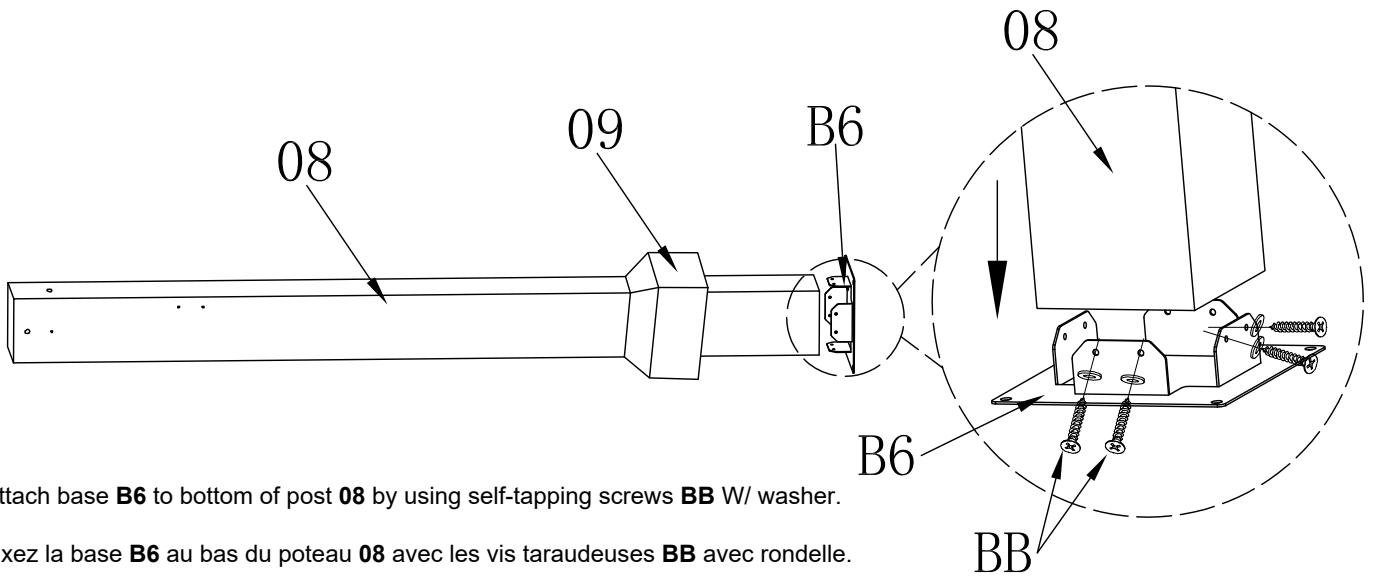

EN: Attach base **B6** to bottom of post **08** by using self-tapping screws **BB** w/ washer.

FR: Fixez la base **B6** au bas du poteau **08** avec les vis taraudeuses **BB** avec rondelle.



B6 4X



BB 32X

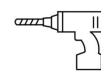

EN: Required drill
FR: Perceuse est nécessaire

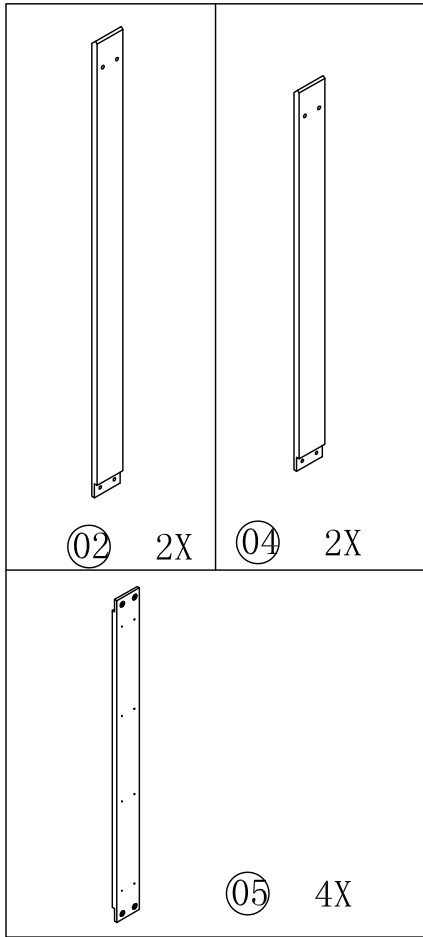

EN: Insert T-Nut **PP** to long side outer right beams **02**/short side outer right beams **04**/inner middle beam **05**.

<3>

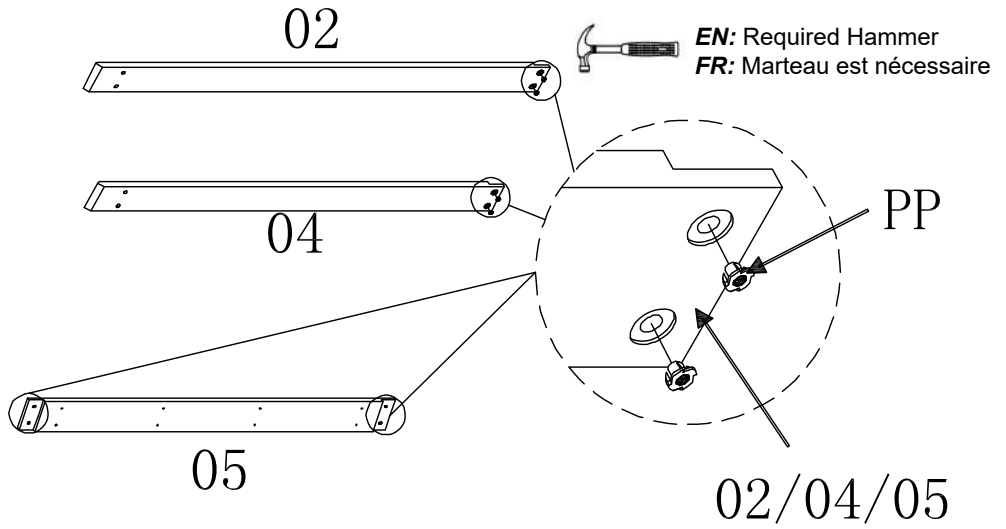

FR: Insérer l'écrou en T **PP** aux poutres extérieures droites **02** des poutres latérales longues/ extérieures droites **04** des poutres latérales courtes/centrales intérieures **05**.



PP 24X

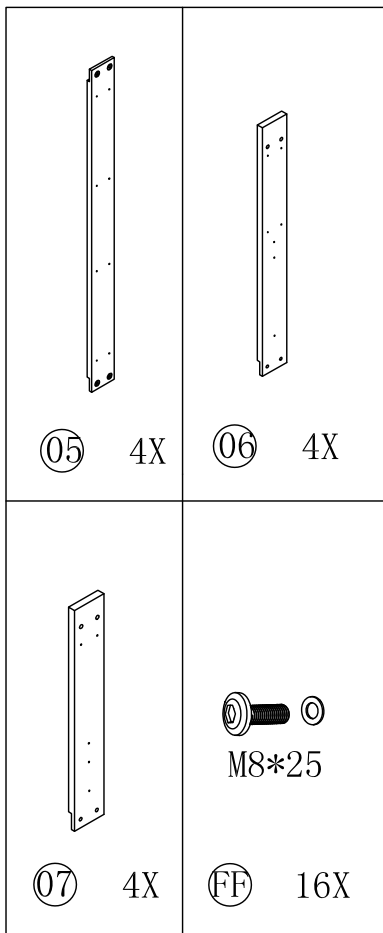

<4>

EN: Connect inner middle beam **05** with 2 long side short beam **06** fasten by using screws **FF**, Connect inner middle beam **05** with 2 short side short beams **07** fasten by using screws **FF**.

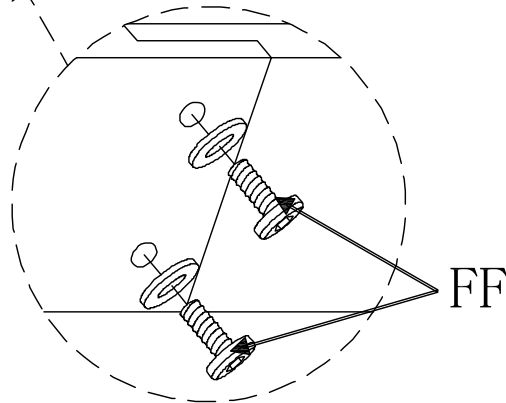
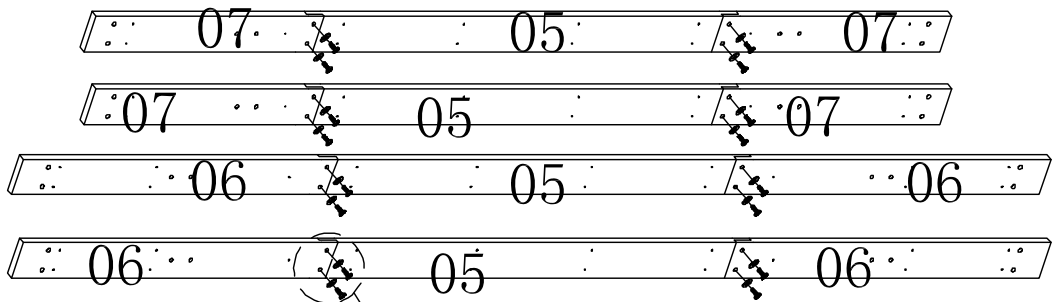

FR: Connecter la poutre centrale intérieure **05** avec 2 poutres courtes **06** de côté long, fixer avec les vis **FF**, connecter la poutre centrale intérieure **05** avec 2 poutres courtes **07** de côté court, fixer avec les vis **FF**.

<5>

EN: Connect middle covers **F8** with long side outer left/right beam **01/02**, fasten by using screws W/ washer **FF**, Connect middle covers **F8** with short side outer left/right Beam **03/04**, fasten by using screws W/ washer **FF**.

FR: Connectez les couvercles du milieu **F8** avec la poutre extérieure gauche/droite **01/02** de côté long, fixez à l'aide de vis avec rondelle **FF**, connectez les couvercles centraux **F8** avec la poutre extérieure gauche/droite **03/04** de côté court, fixez à l'aide de vis avec rondelle **FF**.

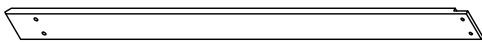
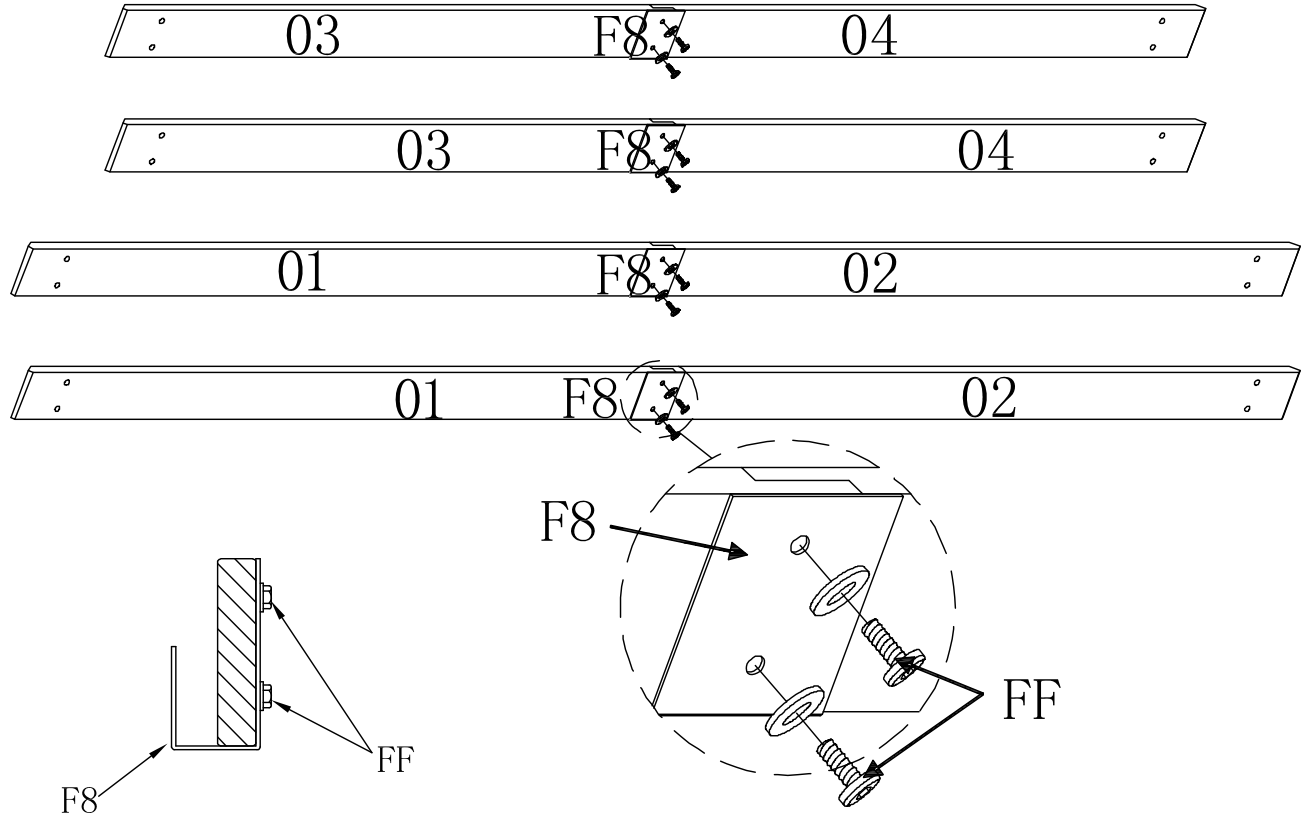

① 2X

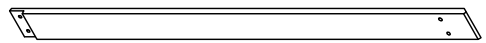

② 2X

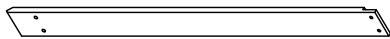

③ 2X

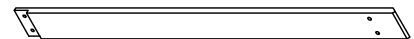

④ 2X



ⓕ 4X



M8*25

ⓕ 8X

<6>

EN: Insert assembled short side inner beams **05/07** into assembled short side outer beams **03/04** by using screw **EE**. Insert assemble long side inner beam **05/06** into assembled long side outer beams **01/02** by using screw **EE**.

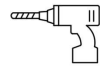
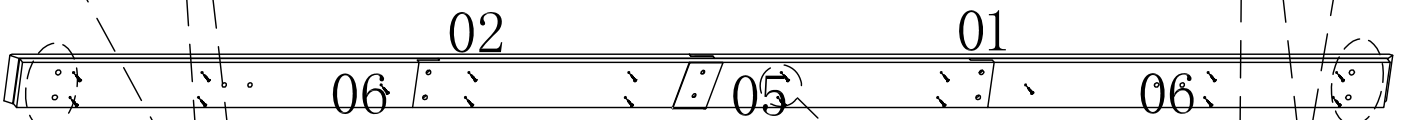
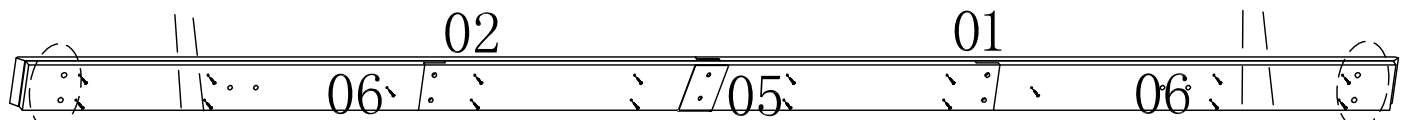
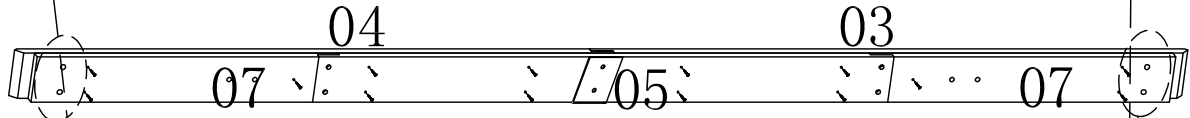
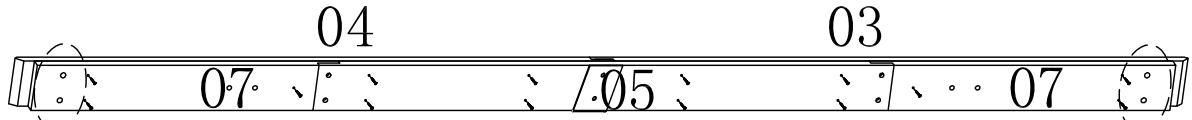

EN: Required drill

FR: Perceuse est nécessaire

EN: Note: Before connecting, ensure the all inner holes aligned with outer holes.

FR: Avis: Avant de vous connecter, assurez-vous que tous les trous intérieurs sont alignés avec les trous extérieurs.



(STEP1)

(STEP3)

(STEP2)

FR: Insérez les poutres iintérieures assemblées **05/07** de côté court dans les poutres extérieures assemblées **03/04** de côté court à l'aide d'une vis **EE**. Insérez l'assemblage de la poutre intérieure **05/06** du côté long dans les poutres extérieures assemblées **01/02** de côté long avec les vis **EE**.

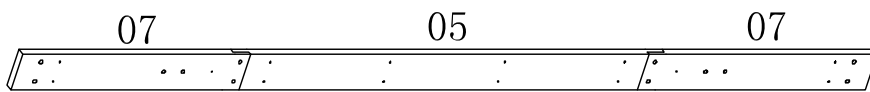

2X

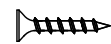

M5*40



64X

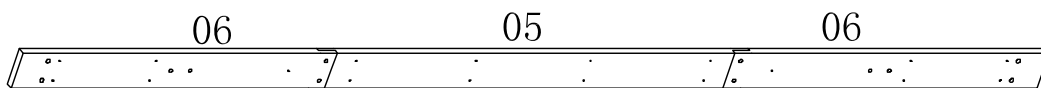

2X

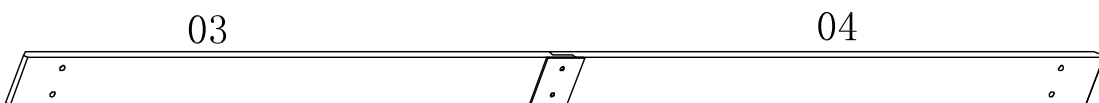

2X

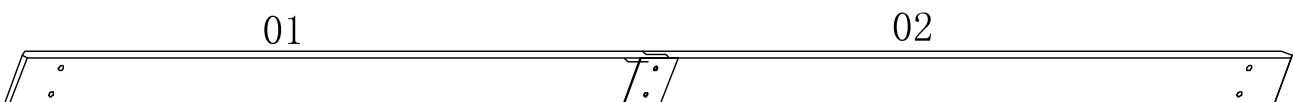

2X

<7>

EN: Lay flat post **08** on ground, attach assembled long side beam **01/02//05/06** and corner covers **F9** to post **08** by using bolts **AA**, screws **CC** and Nut **MM**, Don't lock it.
 (Note: Bolts **AA** used for hole on post, self-tapping screws **CC** used for leading hole on post.)

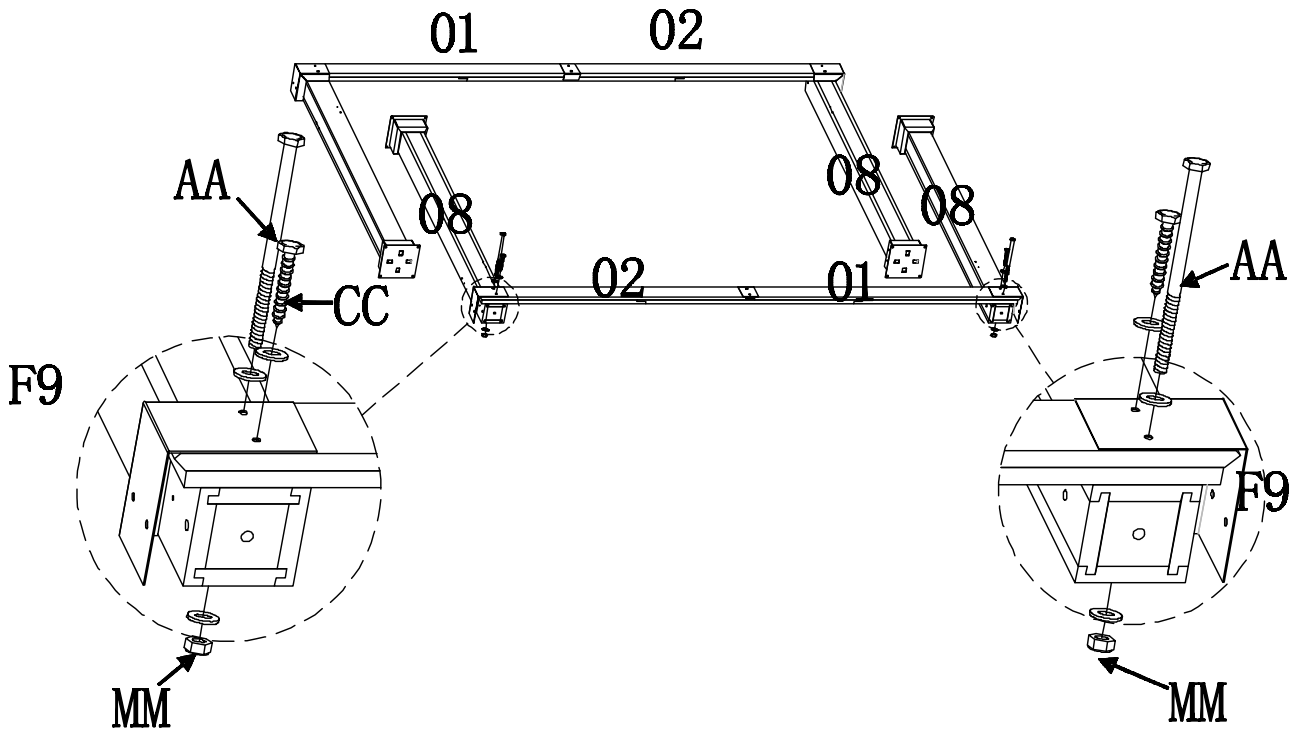

FR: Posez le poteau plat **08** sur le sol, fixez la poutre latérale longue assemblée **01/02//05/06** et les couvercles d'angle **F9** au poteau **08** avec les boulons **AA**, des vis **CC** et des écrous **MM**, ne le verrouillez pas.
 (Avis: boulons **AA** utilisés pour trou sur poteau, vis taraudeuses **CC** utilisées pour trous guidés sur poteau.)

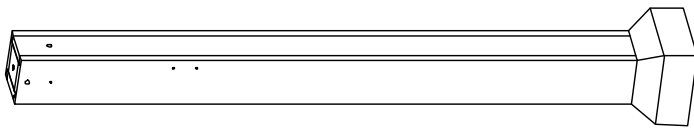

4X

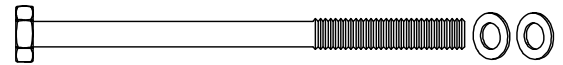

M10*205

Ⓐ 4X

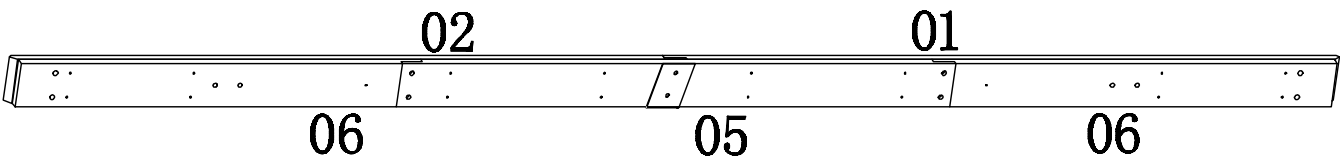

2X

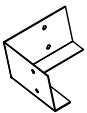

Ⓕ 4X

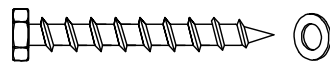

M10*80

Ⓒ 4X



M10

Ⓜ 4X

<8>

EN: Connect assembled short side Beam **03/04/05/07** with assembled corner covers/long side beam/post **F9/01/02/05/06/08** by using bolts **AA**, screws **CC** and nut **MM**, then lock long /short side beam and post.

FR: Connectez la poutre latérale courte assemblée **03/04/05/07** avec les couvercles d'angle assemblés / poutre latérale longue/poteau **F9/01/02/05/06/08** avec les boulons **AA**, les vis **CC**, l'écrou **MM**, puis le verrouillage long / poutre latérale courte et poteau.

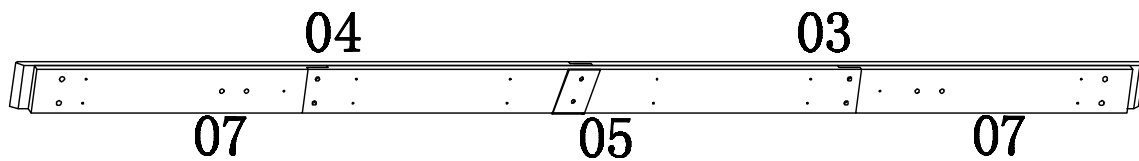
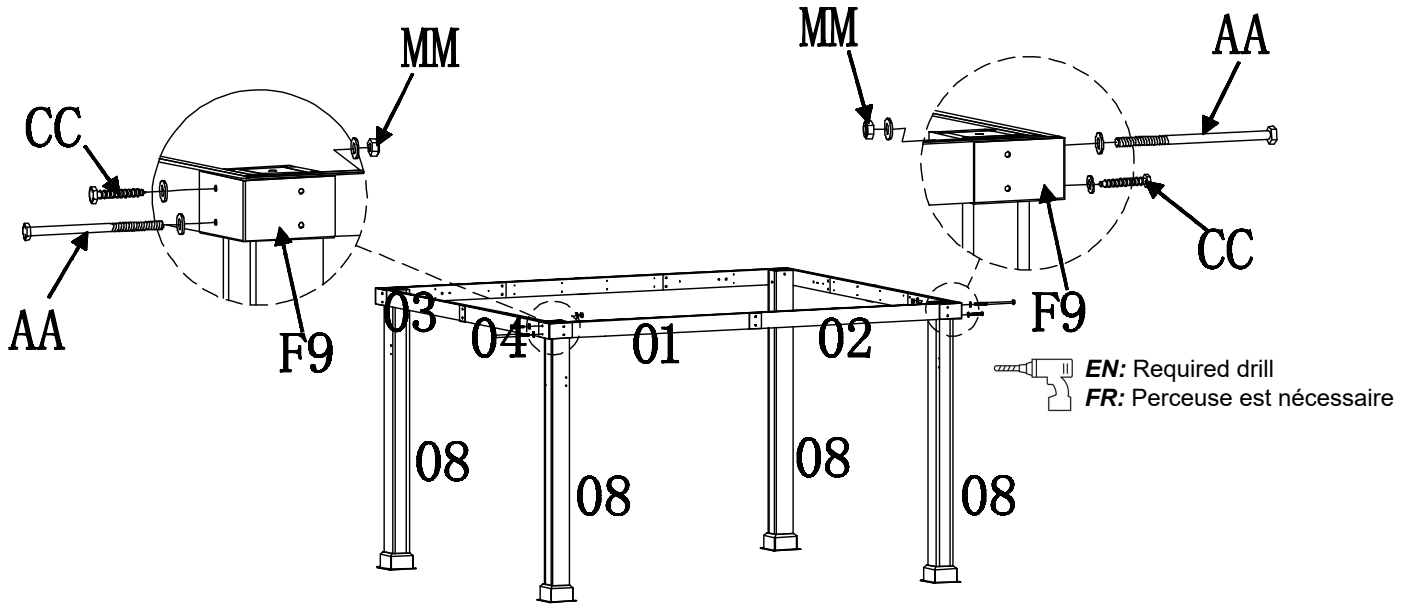

2X

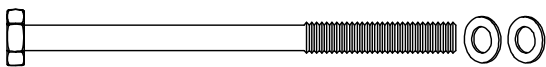

M10*205

AA 4X



M10

MM 4X

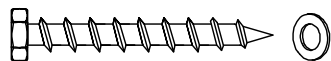

M10*80

CC 4X

<9>

EN: Attach top of left/right support 10/11 to assembled beam and attached the bottom of Left/right support 10/11 to post 08 by using self-tapping screws DD.

FR: Fixez le haut du support gauche/droit 10/11 à la poutre assemblée et fixez le bas du support gauche/droit 10/11 au poteau 08 avec les vis taraudeuses DD.

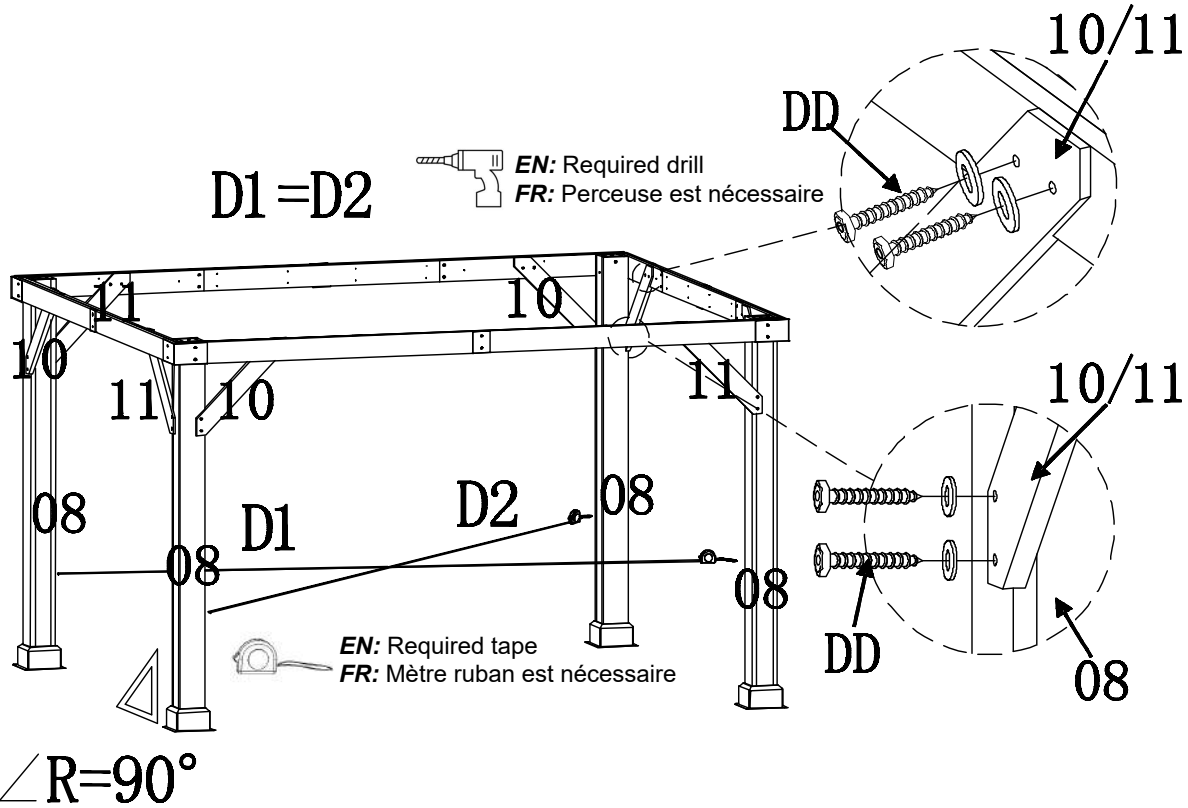

EN: Note: Make sure the distances are equal between two diagonals of posts by using tape before to next assemble step. Keep the beam at right angles to the post, the post at right angles to the ground, and keep the beam horizontal.

FR: Avis: Assurez-vous que les distances sont égales entre deux diagonales de poteaux en utilisant du ruban à mesurer avant l'étape suivante d'assemblage. Maintenez la poutre perpendiculaire au poteau, le poteau perpendiculairement au sol et maintenez la poutre horizontale.

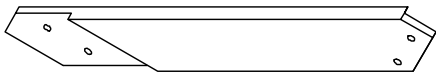

⑩ 4X

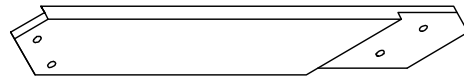

⑪ 4X

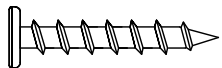

⊙ M8*35

⊙ DD 32X

<10>

EN: Attach long curtain bar **E1** to inner long side beam, attach short curtain bar **E2** to inner short side beam, fasten by using self-tapping screws **EE** w/ washers **JJ**.
Note: ensure the distance from edge of long curtain bar **E1** to the post **08** is 1.2 inch and ensure the distance from edge of short curtain bar **E2** to the post **08** is 0.6 inch.

EN: Measure length by tape
FR: Mesure de longueur avec les mètre ruban

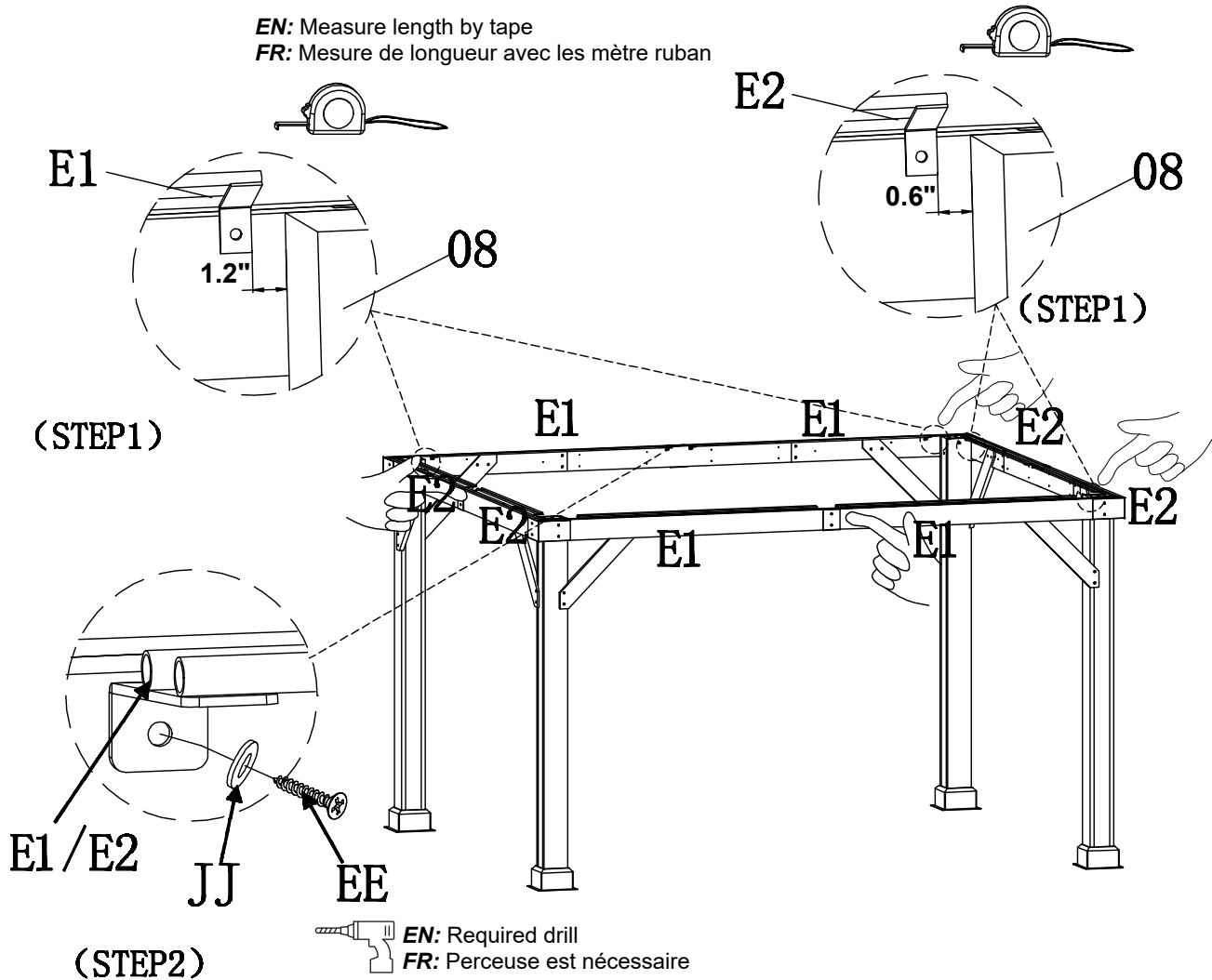

FR: Fixez la longue barre à rideau **E1** à la poutre latérale longue intérieure, fixez la barre de rideau courte **E2** à la poutre latérale courte intérieure, fixez avec les vis taraudeuses **EE** avec rondelles **JJ**.

Avis: assurez-vous que la distance entre le bord de la longue barre de rideau **E1** et le poteau **08** est de 1.2" et assurez-vous que la distance entre le bord de la barre de rideau courte **E2** et le poteau **08** est de 0.6".

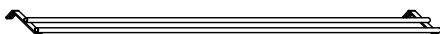

E1 4X

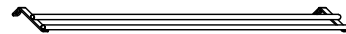

E2 4X

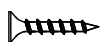

M5*40

EE 16X



JJ 16X

<11>

 **EN:** Required drill
FR: Perceuse est nécessaire

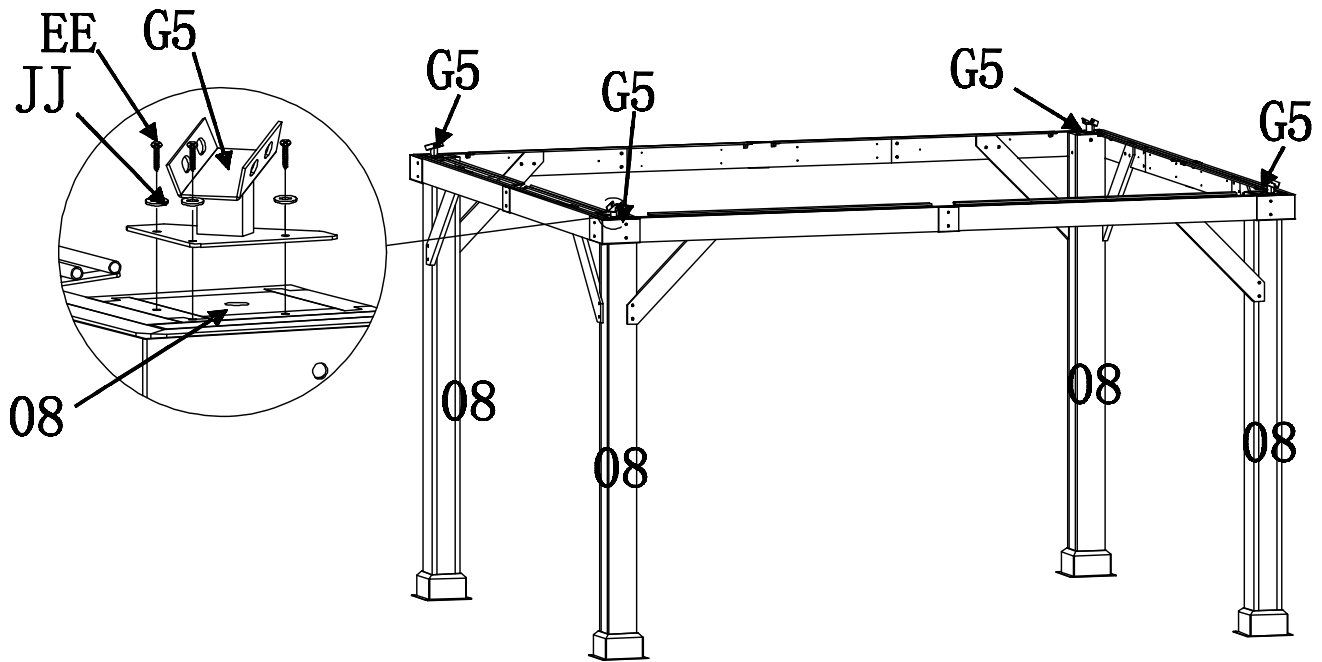

EN: Attach slant beam bottom connectors **G5** to the top of post **08** by using self-tapping screws **EE** w/ washers **JJ**.

FR: Fixez les connecteurs inférieurs inclinés **G5** au sommet du poteau **08** avec les vis taraudeuses **EE** avec rondelles **JJ**.



G5 4X



EE 12X



JJ 12X

<12>

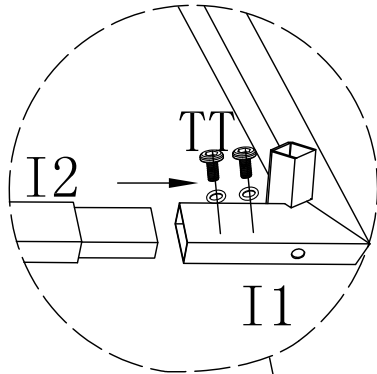

EN: Connect short side tubes of big roof I1 with the long side tubes of big roof I2 by using screws TT.

FR: Connectez les tubes latéraux courts du grand toit I1 avec les tubes latéraux longs du grand toit I2 avec les vis TT.

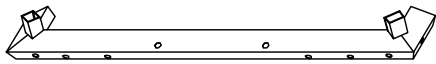
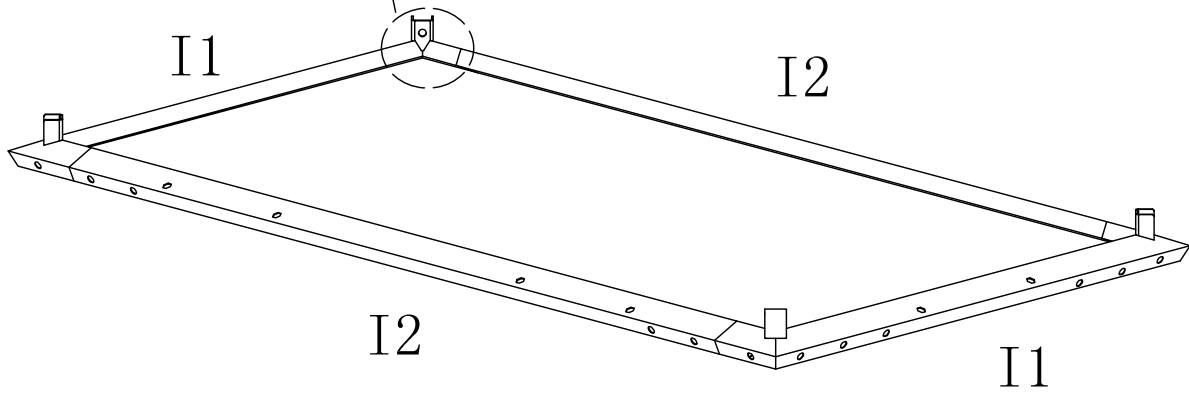

⑪ 2X

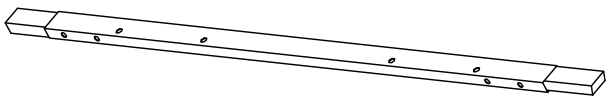

⑫ 2X



TT 8X

<13>

EN: Connect top of big roof middle beam **H1** with the short tubes **I2** of big roof by using screws **TT**.

FR: Connectez le haut de la poutre centrale **H1** du grand toit avec les tubes courts **I2** du grand toit avec les vis **TT**.

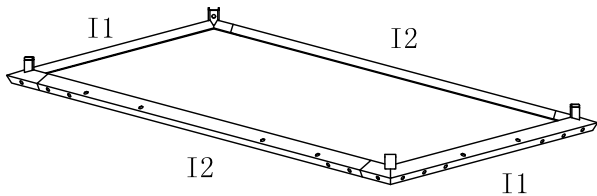
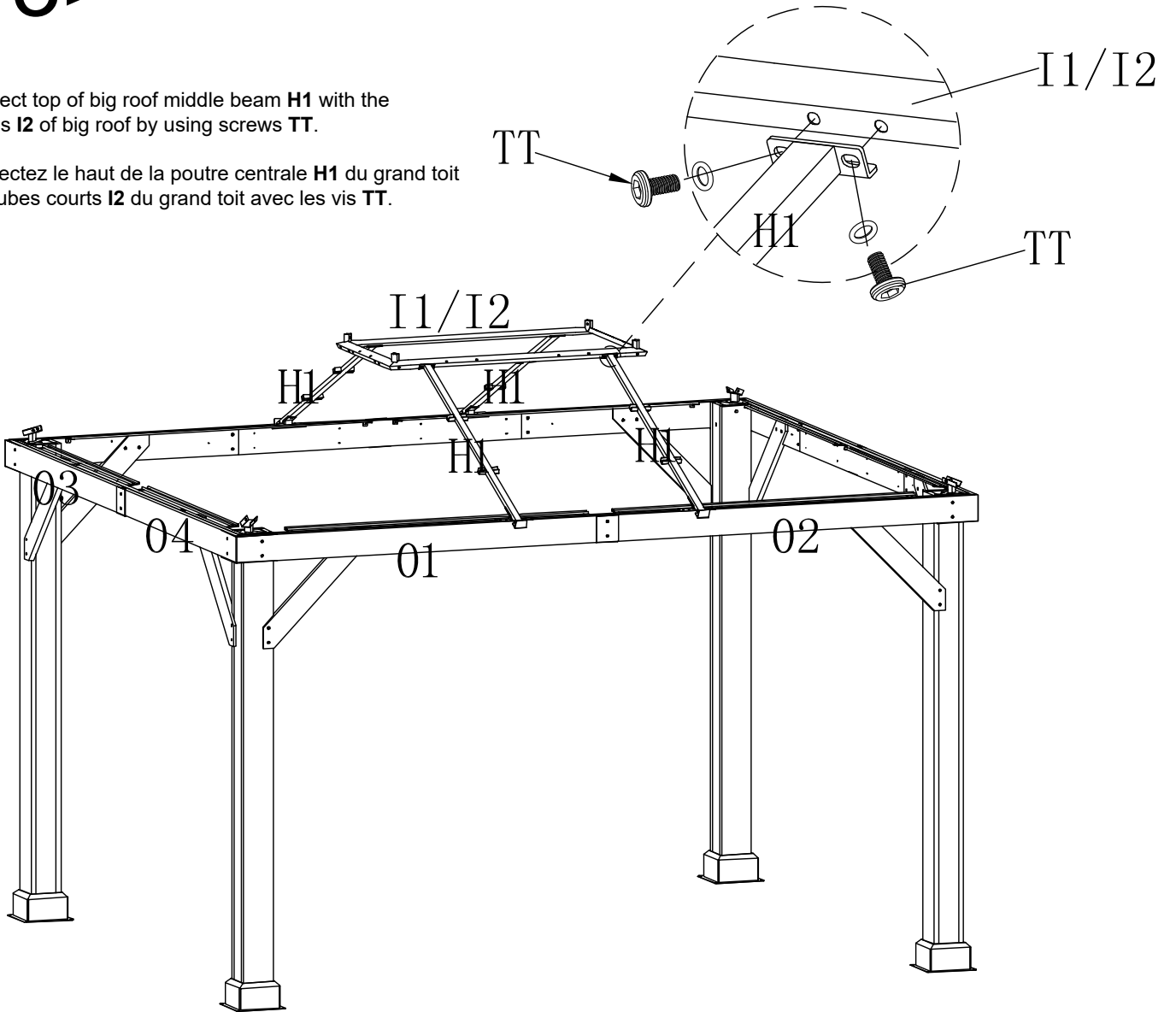

1X

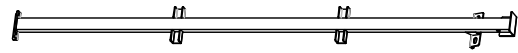

(H1) 4X



M6*15

(TT) 8X

<14>

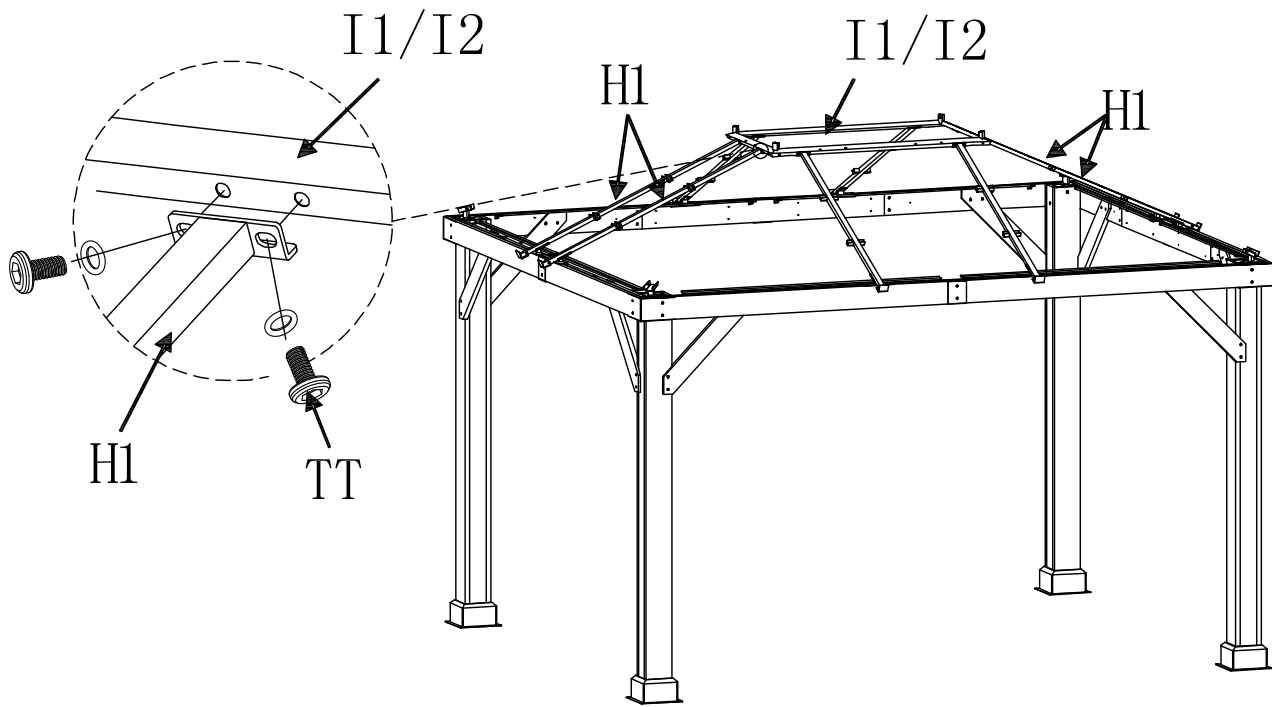

EN: Connect top of big roof middle beam **H1** with the short tubes **I1** of big roof by using screws **TT**.

FR: Connectez le haut de la poutre centrale **H1** du grand toit avec les tubes courts **I1** du grand toit avec les vis **TT**.

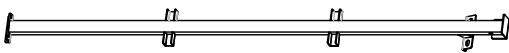

(H1) 4X



M6*15

(TT) 8X

<15>

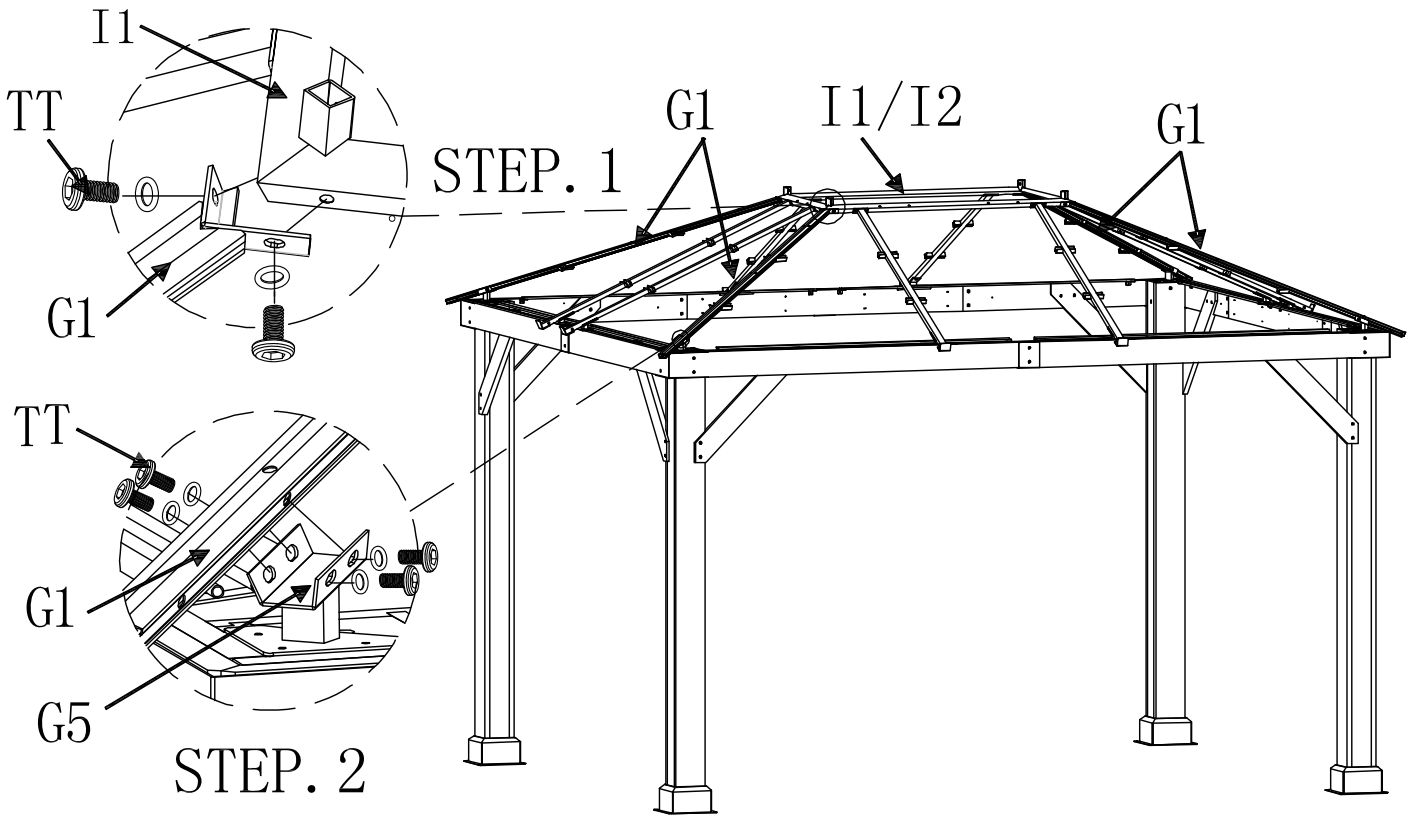

EN: Connect top of long slant beam **G1** with the short /long side tubes **I1/I2** of big roof by using screws **TT**, then connect bottom of long slant beam **G1** with slant beam bottom connector **G5** by using screws **TT**.

FR: Connectez le haut de la longue poutre inclinée **G1** avec les tubes latéraux courts/longs **I1/I2** du grand toit avec les vis **TT**, puis Connectez le bas de la poutre oblique longue **G1** avec le connecteur inférieur de la poutre oblique **G5** à l'aide de vis **TT**.



ⓐ G1 4X



ⓐ TT 24X

<16>

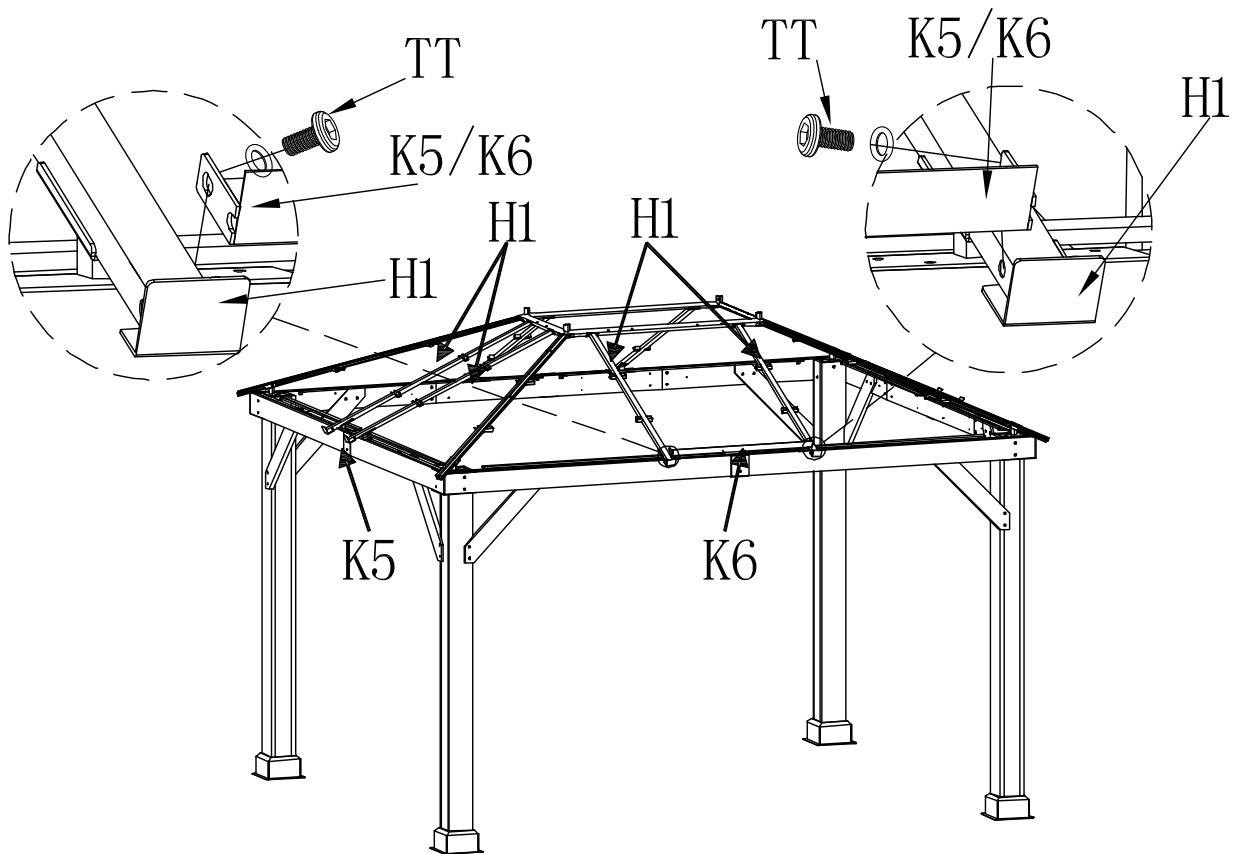

EN: Insert two ends of big roof short/long middle blocking bar **K5/K6** to the bottom of big roof middle beam **H1** and big roof slant beam **G1** by using screws **TT**.

FR: Insérer deux extrémités de barre de blocage centrale courte/longue **K5/K6** de grand toit au bas de la poutre centrale **H1** du grand toit et poutre inclinée **G1** du grand toit avec les vis **TT**.

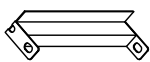

Ⓚ5 2X



M6*15

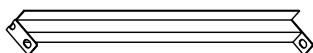

Ⓚ6 2X

Ⓣ1 8X

<17>

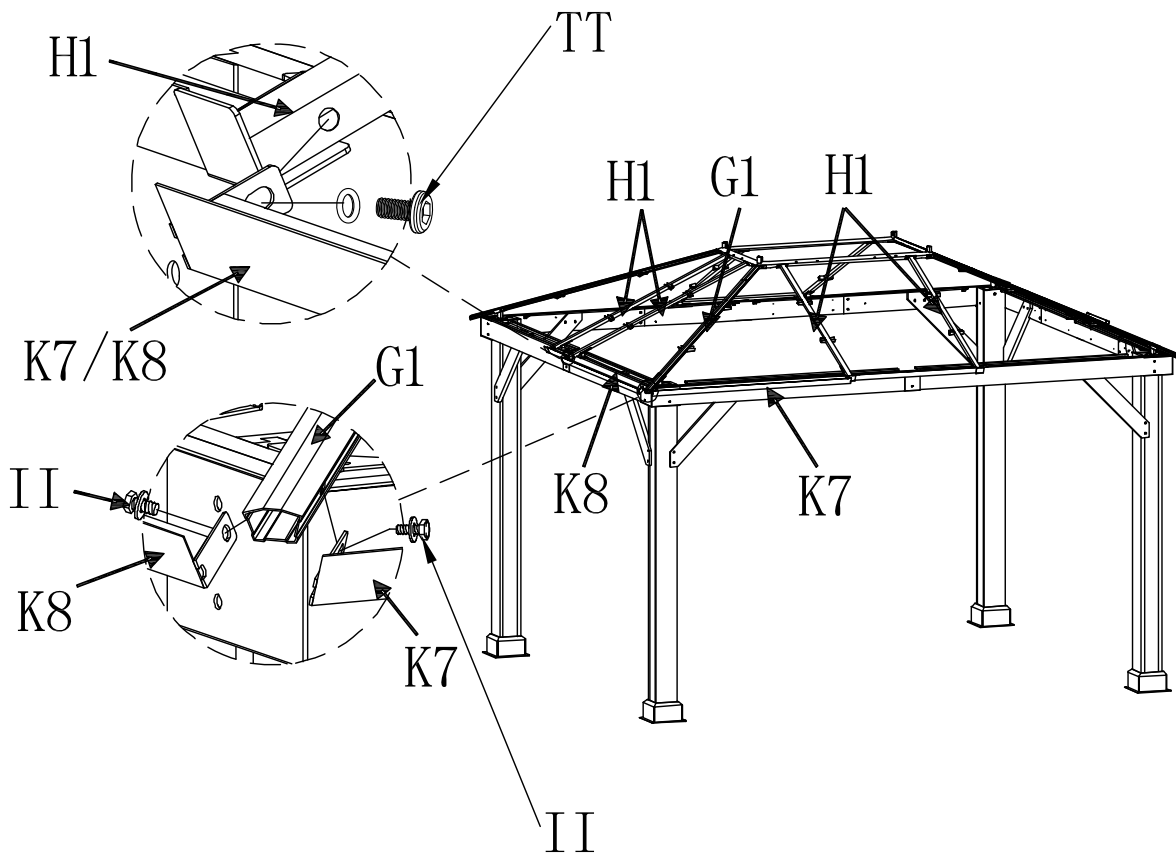

EN: Insert two ends of big roof left/right blocking bar **K7/K8** to the bottom of big roof middle beam **H1** and big roof slant beam **G1** by using screws **TT**/bolts **II**.

FR: Insérez deux extrémités de barre de blocage gauche/droite **K7/K8** de grand toit au bas de la poutre centrale **H1** du grand toit et de la poutre inclinée **G1** du grand toit avec les vis **TT**/boulons **II**.

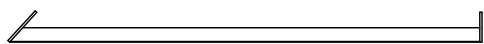

(K7) 4X



M6*15

(TT) 8X

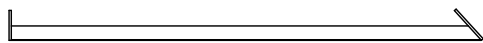

(K8) 4X



M6*15

(II) 8X

<18>

EN: Connect bottom of big roof middle beam **H1** with assembled beam by using self-tapping screws **BB**.

FR: Connectez le bas de la grande poutre centrale **H1** du toit avec la poutre assemblée avec les vis **BB**.

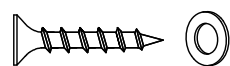
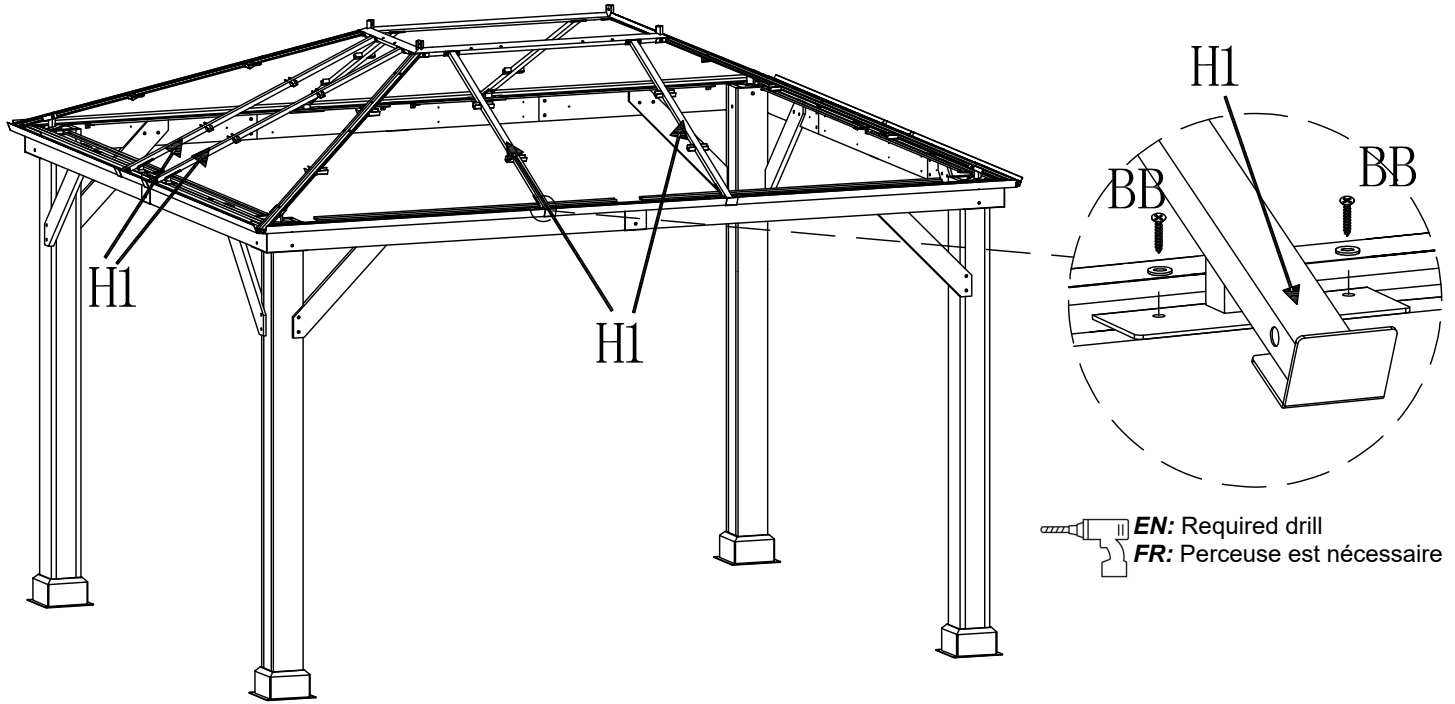

M5*25



16X

<19>

EN: Insert bottom of small roof slant beam **L1** into big roof assembled frame **I1/I2**, then insert small roof slant beam **L1** upper end into small roof connector **M1**.

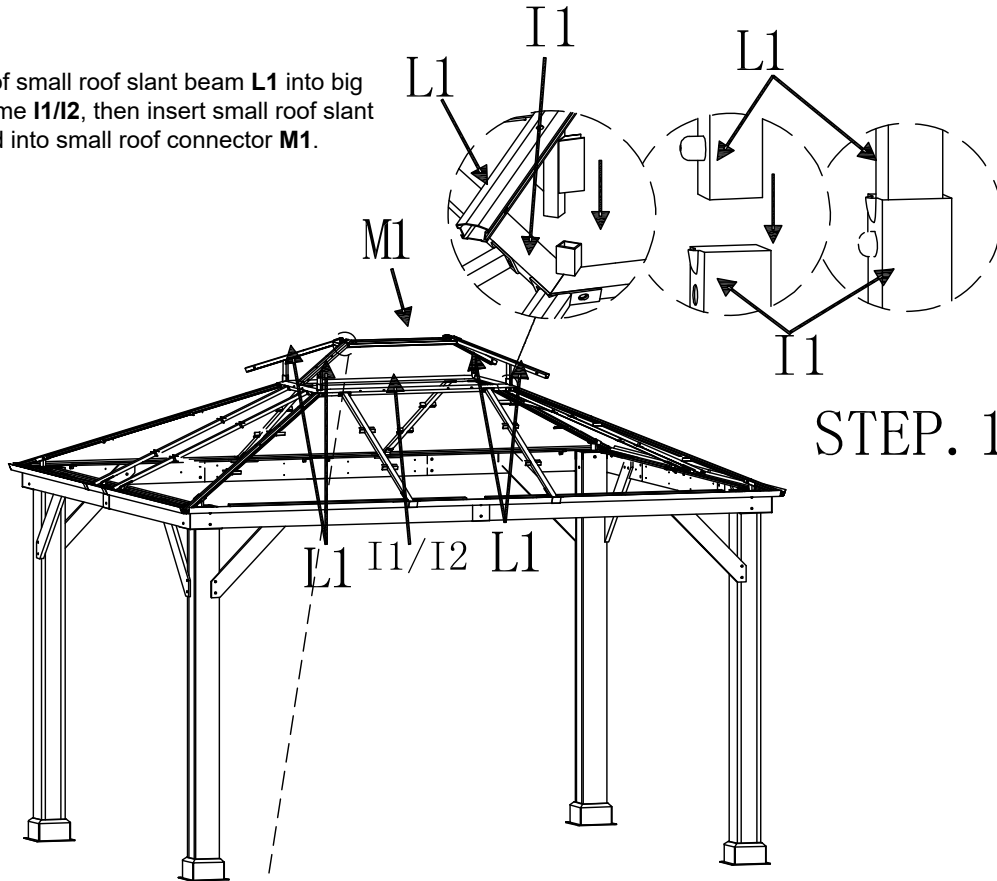

STEP. 1

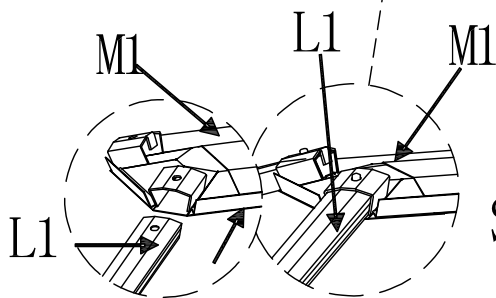

FR: Insérez le bas de la poutre oblique **L1** du petit toit dans le grand toit assemblé cadre **J1/J2**, puis insérez la petite poutre inclinée toit **L1** extrémité supérieure dans le petit connecteur de toit **M1**.

STEP. 2

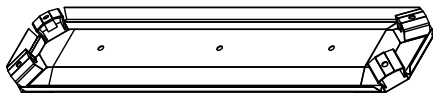

Ⓜ1 1X

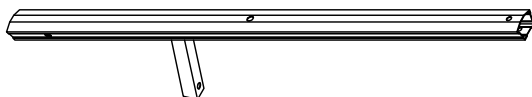

Ⓛ1 4X

<20>

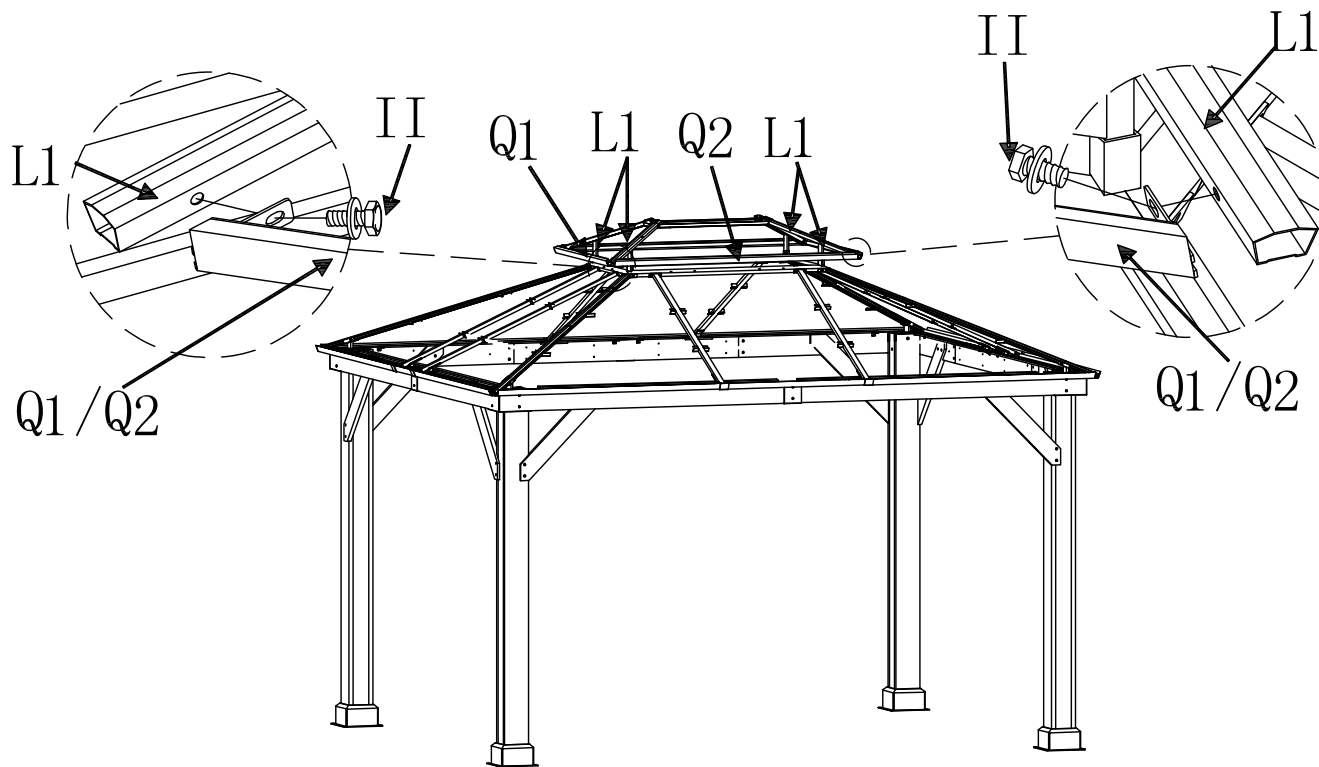

EN: Attach small roof short/long tubes **Q1/Q2** to small roof slant beam **L1** by using bolt **II**.

FR: Fixer des tubes courts/longs de petit toit **Q1/Q2** à une poutre incliné **L1** de petit toit avec les boulon **II**.



Ⓠ 2X

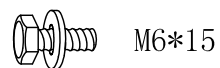

Ⓡ 8X



Ⓠ 2X

<21>

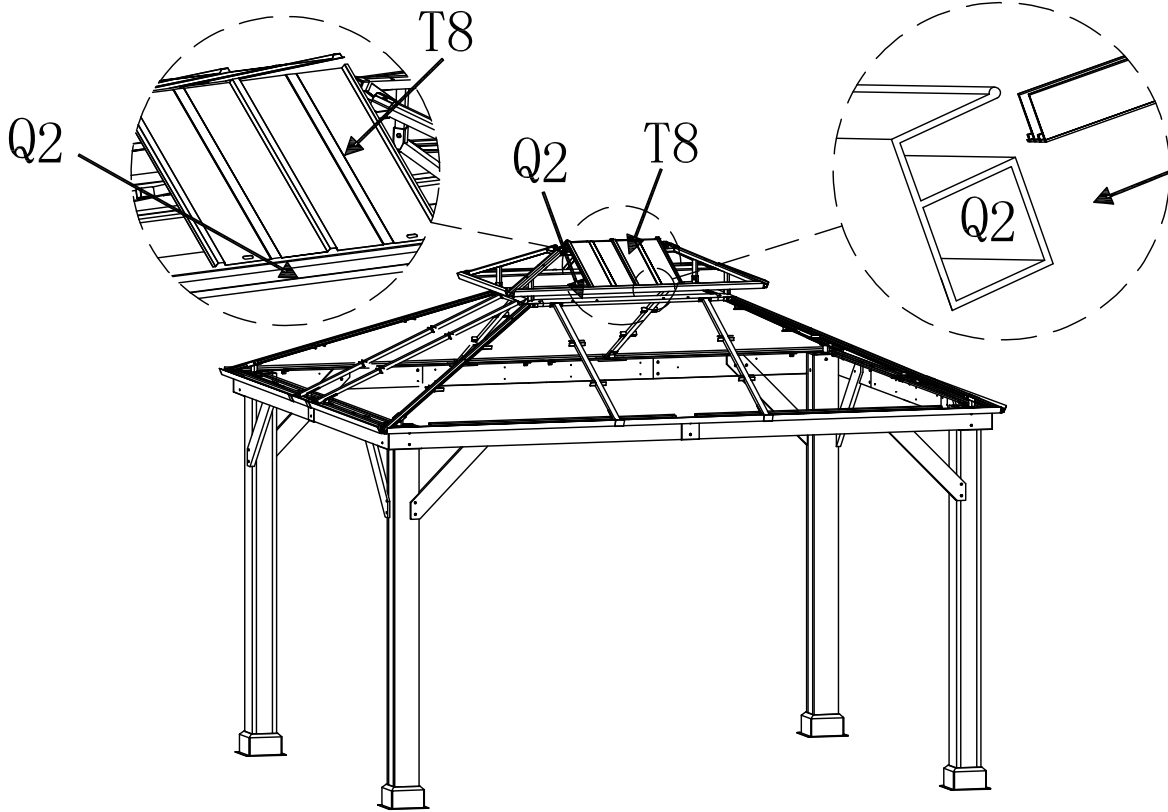

EN: Attach small roof middle cover plate **T8** to small roof assembled frame.
(Note: Insert lower end of cover plate into groove of small roof long tubes **Q2**.)

FR: Fixer la plaque de couverture centrale **T8** de petit toit à la charpente assemblée de petit toit.
(Avis: insérer l'extrémité inférieure de la plaque de couverture dans la rainure de petits tubes longs de toit **Q2**.)

EN: note: Place the small roof cover plate from the middle position to both side.

FR: Avis: Placez la plaque de couverture du petit toit de la position centrale des deux côtés.

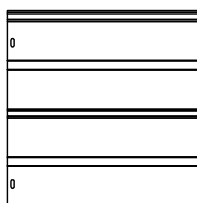

Ⓣ8 2X

<22>

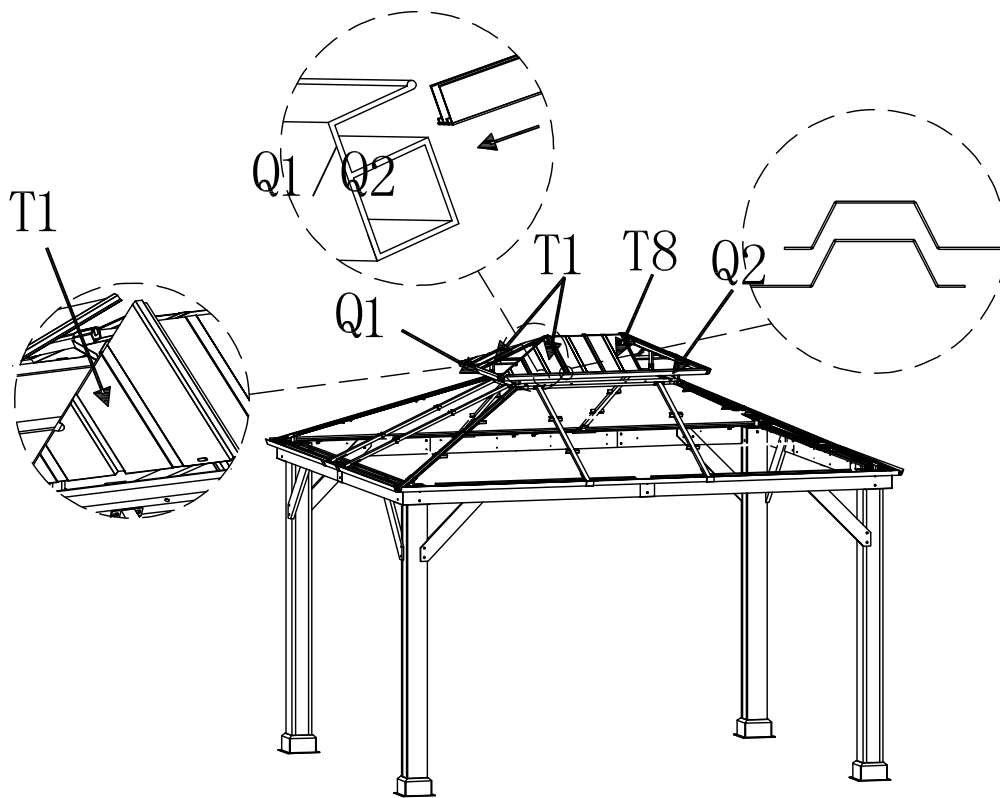

EN: Attach small roof left cover plate **T1** to small roof assembled frame.

(Note: Insert lower end of cover plate into groove of small roof short/long tubes **Q1/Q2**, connection of cover plates are interlock.)

FR: Fixer la plaque de couverture gauche **T1** de petit toit à la charpente assemblée de petit toit.

(Avis: Insérer l'extrémité inférieure de la plaque de recouvrement dans la rainure des tubes courts/longs **Q1/Q2** de petit toit, connexion de l'emboîtement de la plaque de recouvrement.)

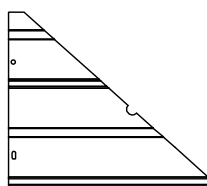

Ⓣ1 4X

<23>

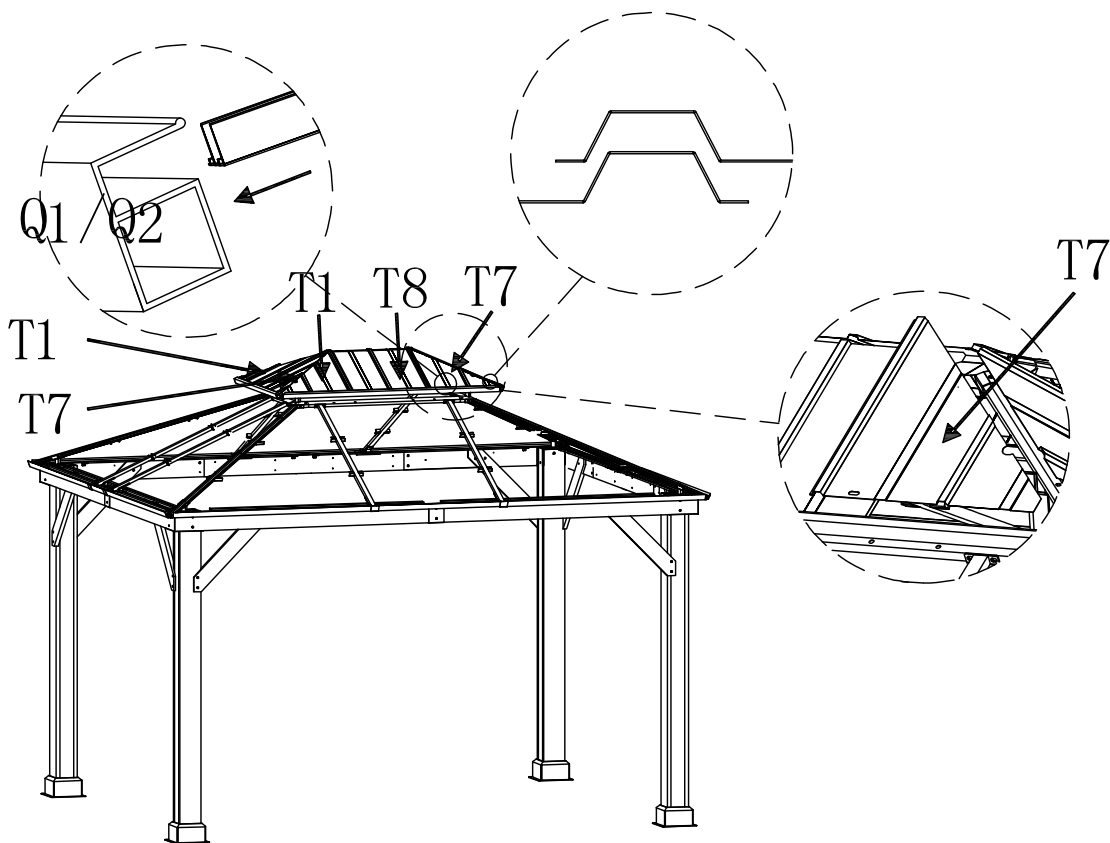

EN: Attach small roof right cover plate **T7** to small roof assembled frame.
(Note: Insert lower end of cover plate into groove of small roof short/long tubes **Q1/Q2**, connection of cover plates are interlock.)

FR: Fixez la plaque de couverture droite du petit toit **T7** à la charpente assemblée du petit toit.
(Avis: Insérez l'extrémité inférieure de la plaque de recouvrement dans la rainure de petits tubes courts / longs de toit **Q1/Q2**, connexion de l'emboîtement de la plaque de recouvrement.)

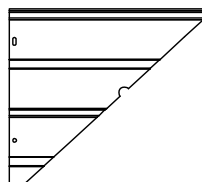

Ⓣ7 4X

<24>

EN: Insert the screws **KK** into the hole of small roof covers **S1**/Big roof slant covers **S2** and secure it with nuts.

FR: Insérez les vis **KK** dans le trou des petits couvercles de toit **S1**/Grandes couvertures inclinées de toit **S2** et fixez-les avec des écrous.

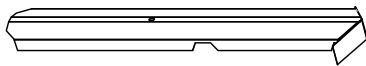
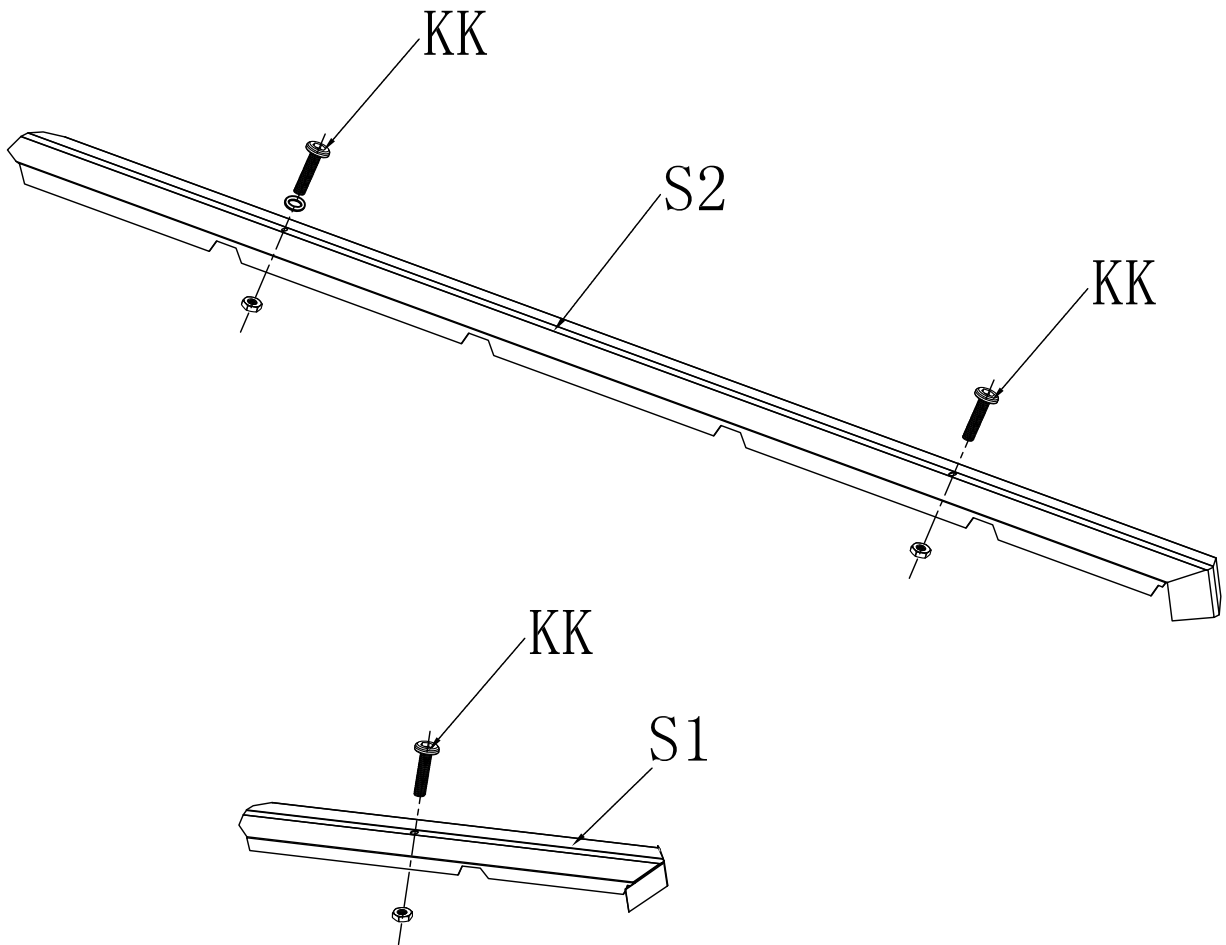

(S1) 4X



(KK) 12X M6*55

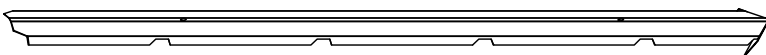

(S2) 4X

<25>

EN: Attach small roof side cover plate **S1** to small roof slant beam **L1**, fix inner side small roof slant beam **L1** by using nuts **GG**.

FR: Fixer la plaque de couverture latérale **S1** de petit toit à la poutre oblique **L1** de petit toit, fixer la poutre inclinée latérale intérieure **L1** de petit toit avec des écrous **GG**.

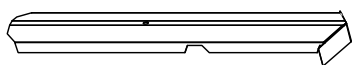
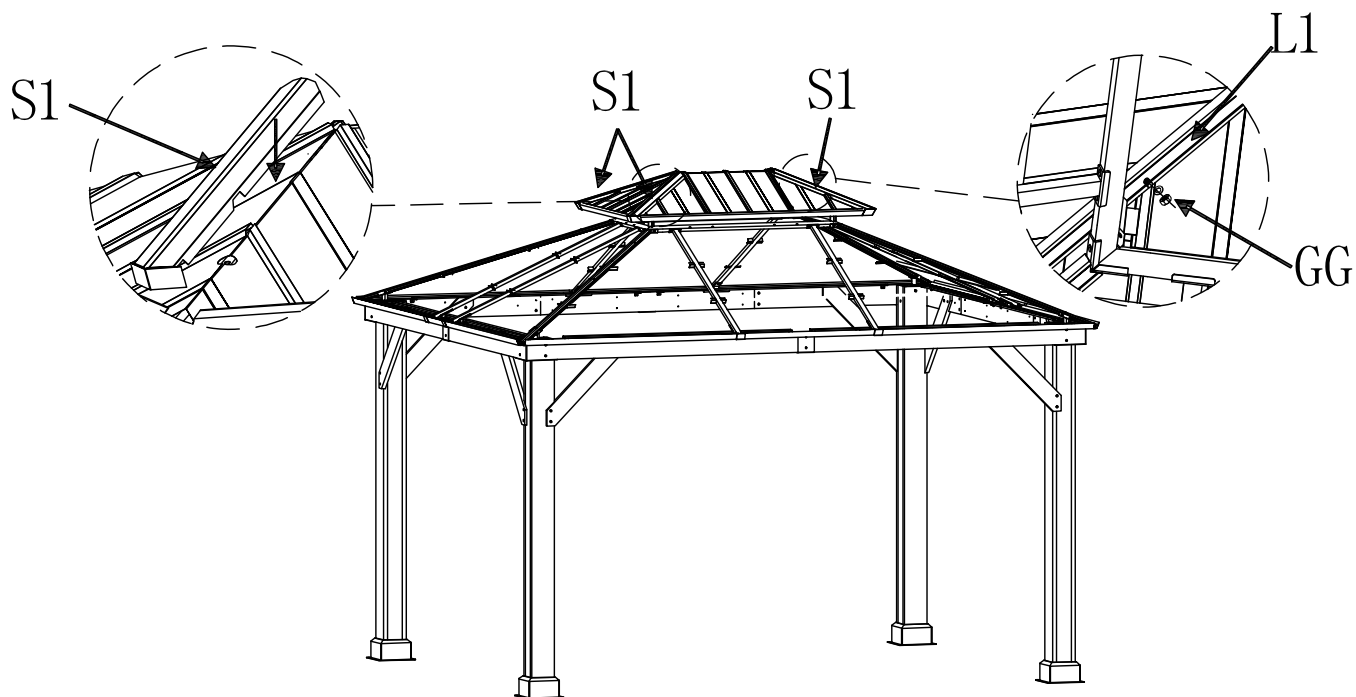

(S1) 4X



(GG) 4X

<26>

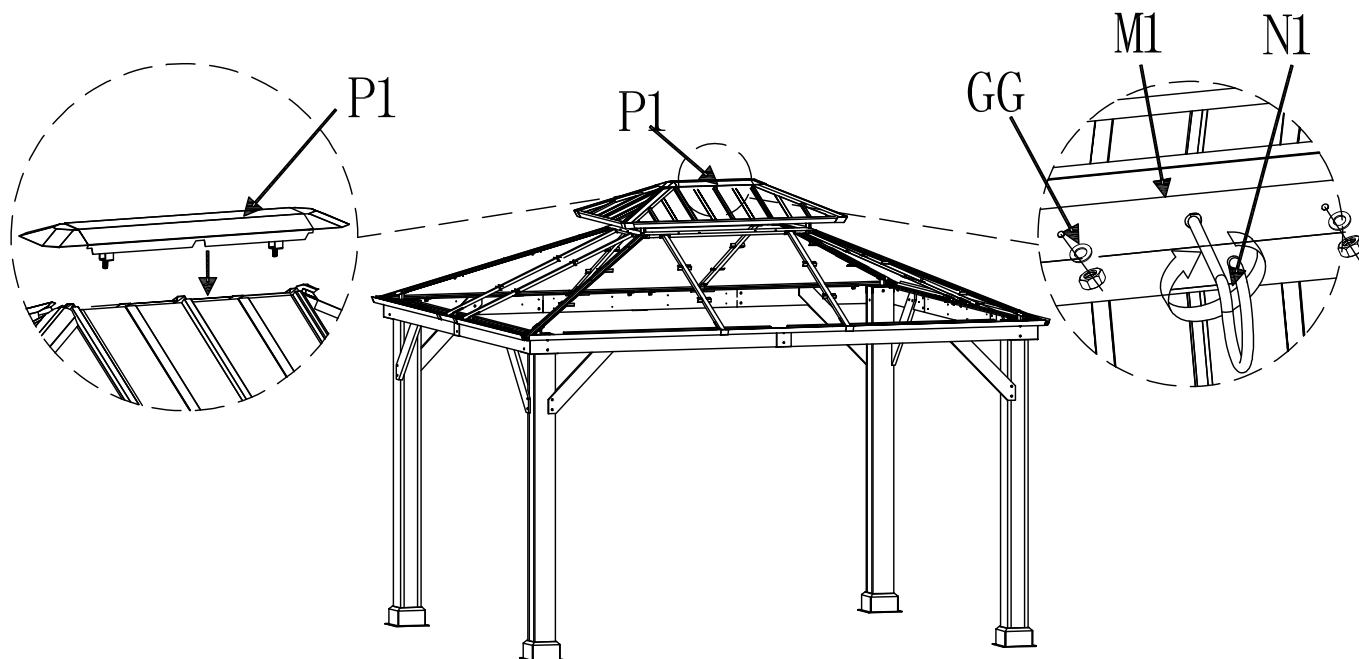

EN: Attach small roof cover **P1** to small roof connector **M1**, fix inner side small roof connector **M1** by using nut W/washer **GG**, then attach Hook **N1** to small roof connector **M1**, turn hook to the right to tighten.

FR: Fixez le petit couvercle de toit **P1** au petit connecteur de toit **M1**, fixez le petit connecteur de toit **M1** du côté intérieur avec les écrou avec rondelle **GG**, puis fixez le crochet **N1** au petit connecteur de toit **M1**, tournez le crochet vers la droite pour serrer.

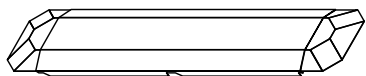

Ⓟ **P1** 1X



Ⓟ **N1** 1X



Ⓟ **GG** 2X

<27>

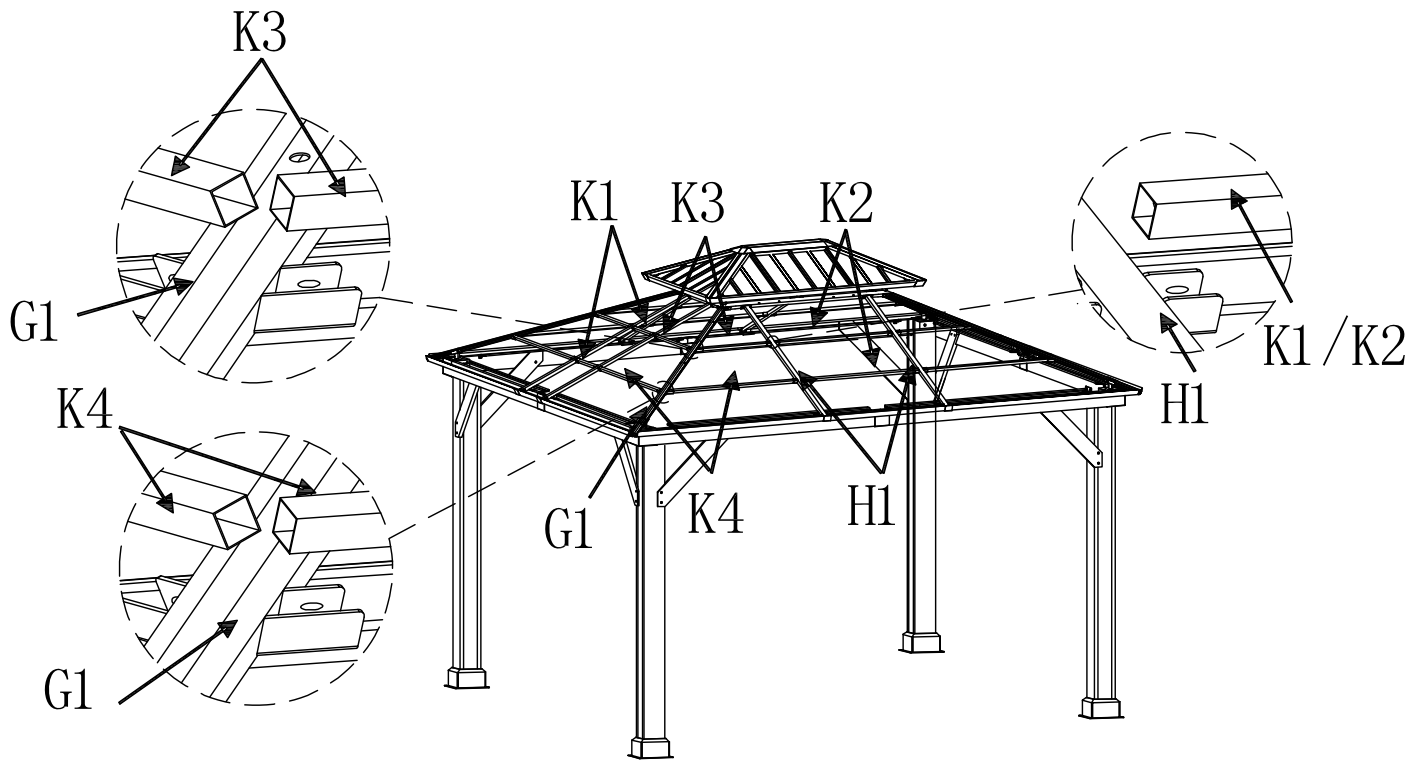

EN: Insert two ends of big roof short/long tubes **K1/K2/K3/K4** to big roof middle beam **H1** and big roof slant beam **G1**.

FR: Insérez deux extrémités de tubes courts/longs **K1/K2/K3/K4** de grand toit à la poutre centrale **H1** de grand toit et à la poutre inclinée **G1** de grand toit.

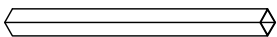

Ⓚ1 4X

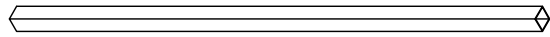

Ⓚ2 4X

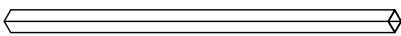

Ⓚ3 8X



Ⓚ4 8X

<28>

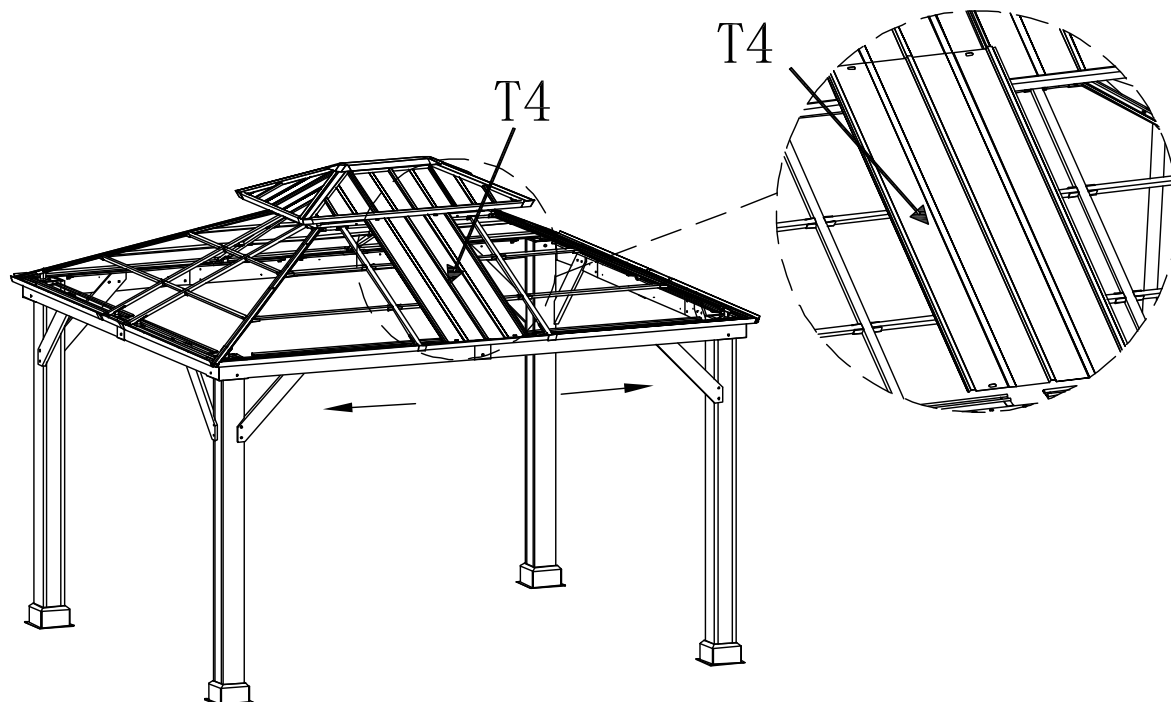

EN: Attach big roof middle cover plate **T4** to big roof assembled frame.

FR: Fixez la plaque de couverture centrale **T4** de grand toit à la charpente assemblée du grand toit.

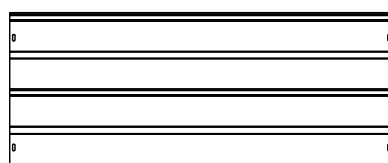

Ⓣ4 2X

<29>

EN: Attach small press panel **R1** to upper of big roof left middle cover plates **T3**/middle cover plates **T4**/ right middle cover plates **T5** to assembled frame by using screws **TT**.

FR: Fixez la petite presse **R1** à la partie supérieure des plaques de couverture centrale gauche **T3**/plaques de couverture centrale **T4**/ plaques de couverture centrale droite **T5** à la charpente assemblée de grand toit avec les vis **TT**.

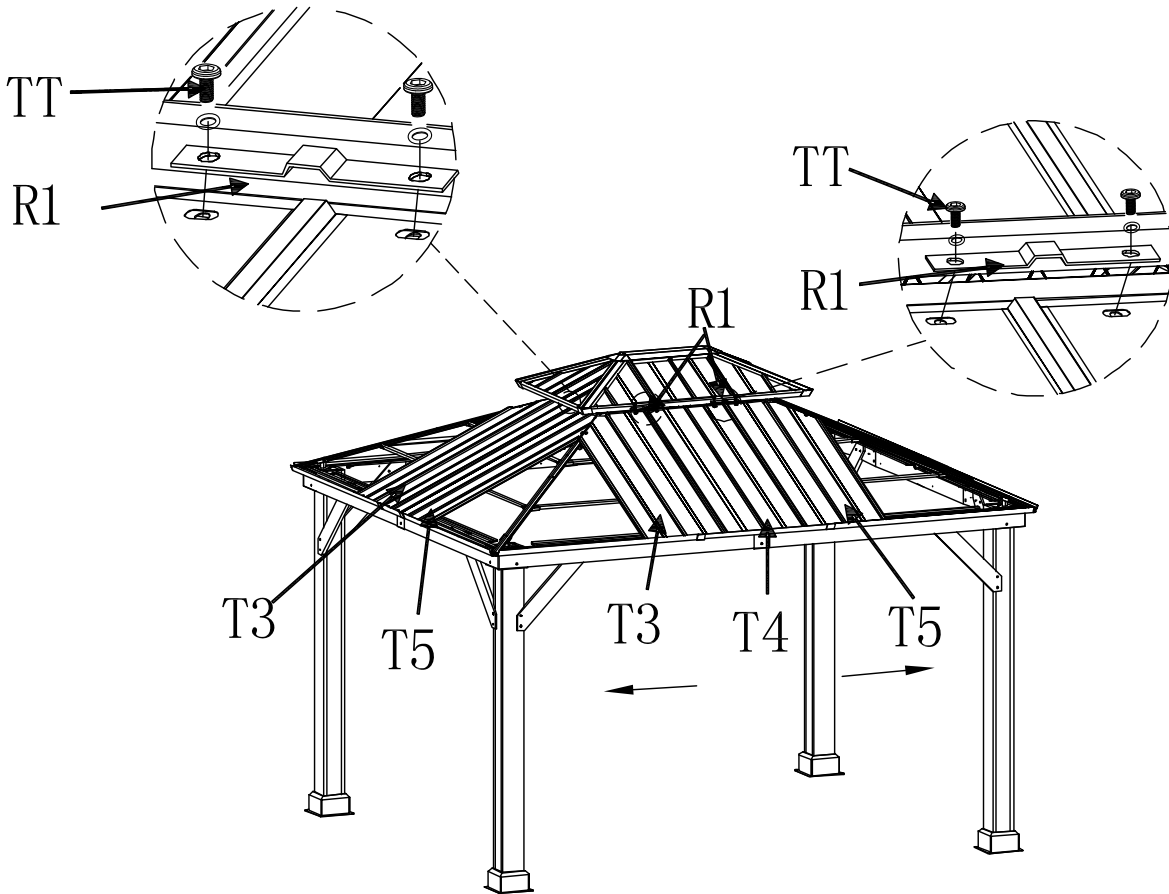

EN: Note: Please do not fully tighten screws **TT** prior to complete assembly for all small/big cover plates in Step 32.

FR: Avis: Veuillez ne pas serrer complètement les vis **TT** avant de terminer l'assemblage pour toutes les petites/grandes plaques de couverture à l'étape 32.

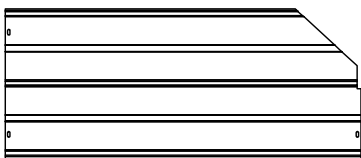

(T3) 4X

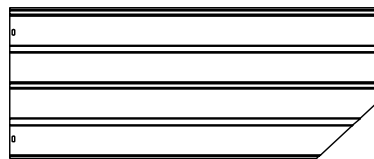

(T5) 4X



M6*15

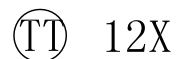

TT 12X

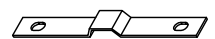

(R1) 6X

<30>

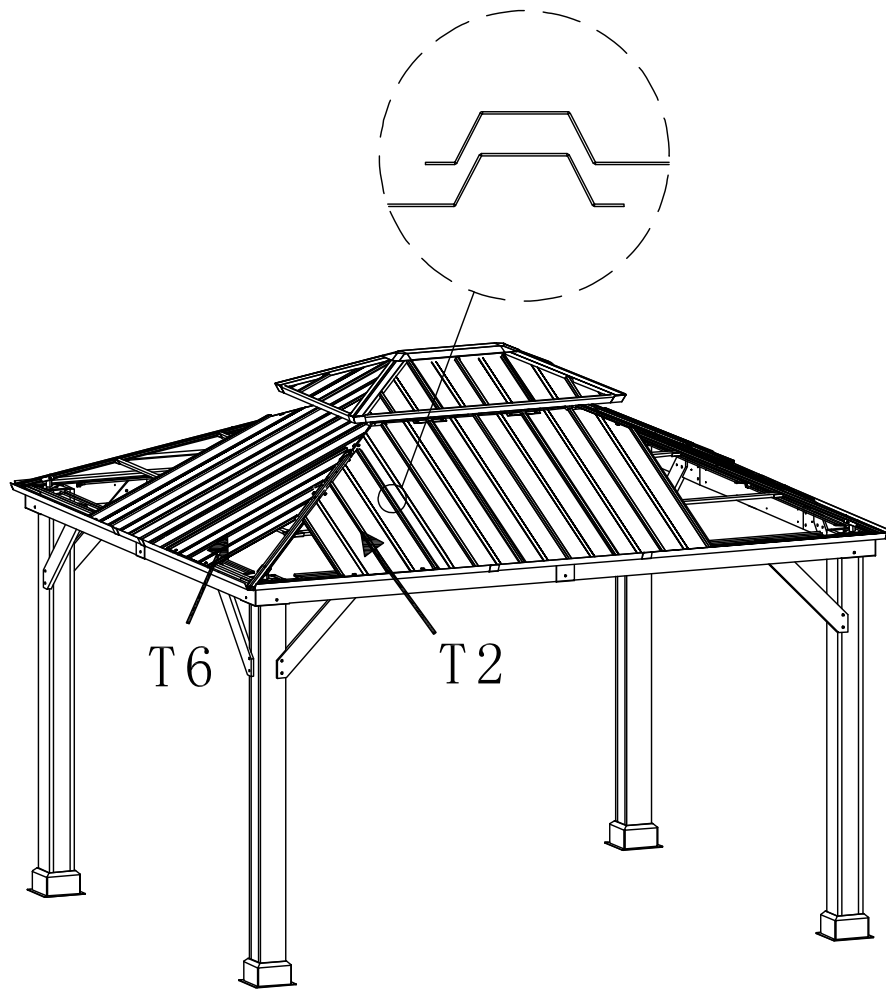

EN: Attach big roof right cover plate **T6** and big roof left cover plate **T2** to the big roof assembled frame.
(Note: connection of cover plates are interlock.)

FR: Fixer la plaque de couverture droite **T6** de grand toit et la plaque de couverture gauche **T2** de grand toit à la charpente assemblée de grand toit.
(Avis: connexion de l'emboîtement de la plaque de recouvrement.)

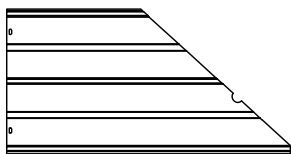

Ⓣ2 4X

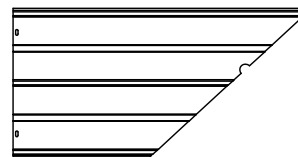

Ⓣ6 4X

<31>

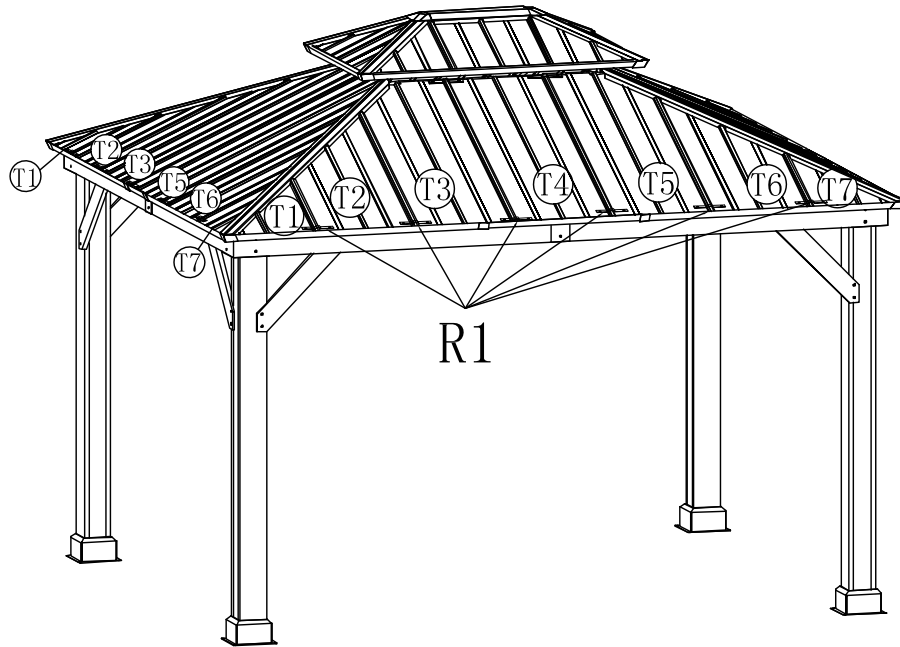

EN: All of the cover plates must be evenly put.

FR: Toutes les plaques de couverture doivent être placées uniformément.

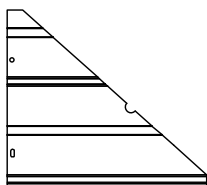

Ⓣ1 4X

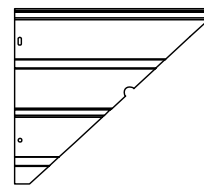

Ⓣ7 4X

<32>

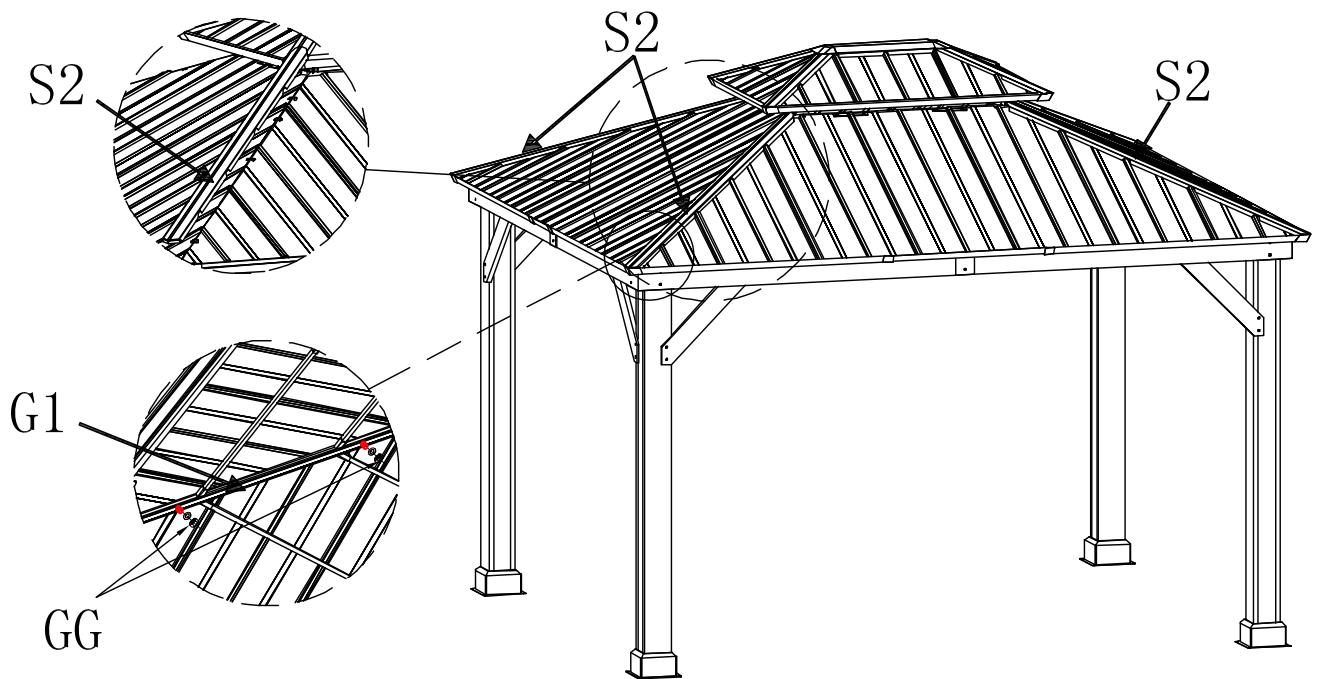

EN: Attach big roof long slant beam cover **S2** to big roof long slant beam **G1**, fix inner side of long slant beam **G1** by using nut W/ washer **GG**.

FR: Fixez le long couvercle de poutre oblique **S2** de grand toit à la poutre oblique longue **G1** de grand toit, fixez le côté intérieur de la poutre oblique longue **G1** avec les écrou avec rondelle **GG**.



Ⓢ2 4X



ⓂⓂ 8X

<33>

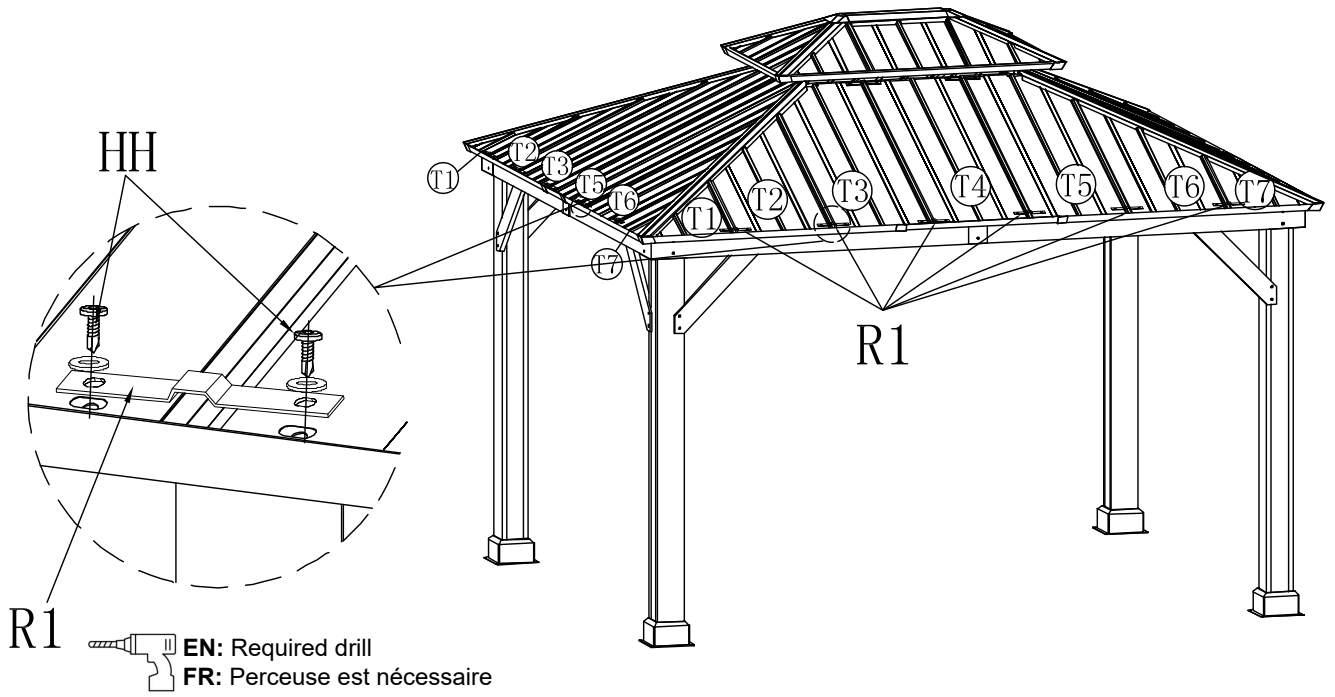

EN: Attach press panel **R1** to the bottom of cover plate to big roof assembled frame by using Bolts **HH**.

FR: Fixez le panneau de presse **R1** au bas de la plaque de couverture à la charpente assemblée du grand toit avec les boulons **HH**.

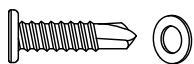

M6*15



44X

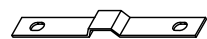

22X

<34>

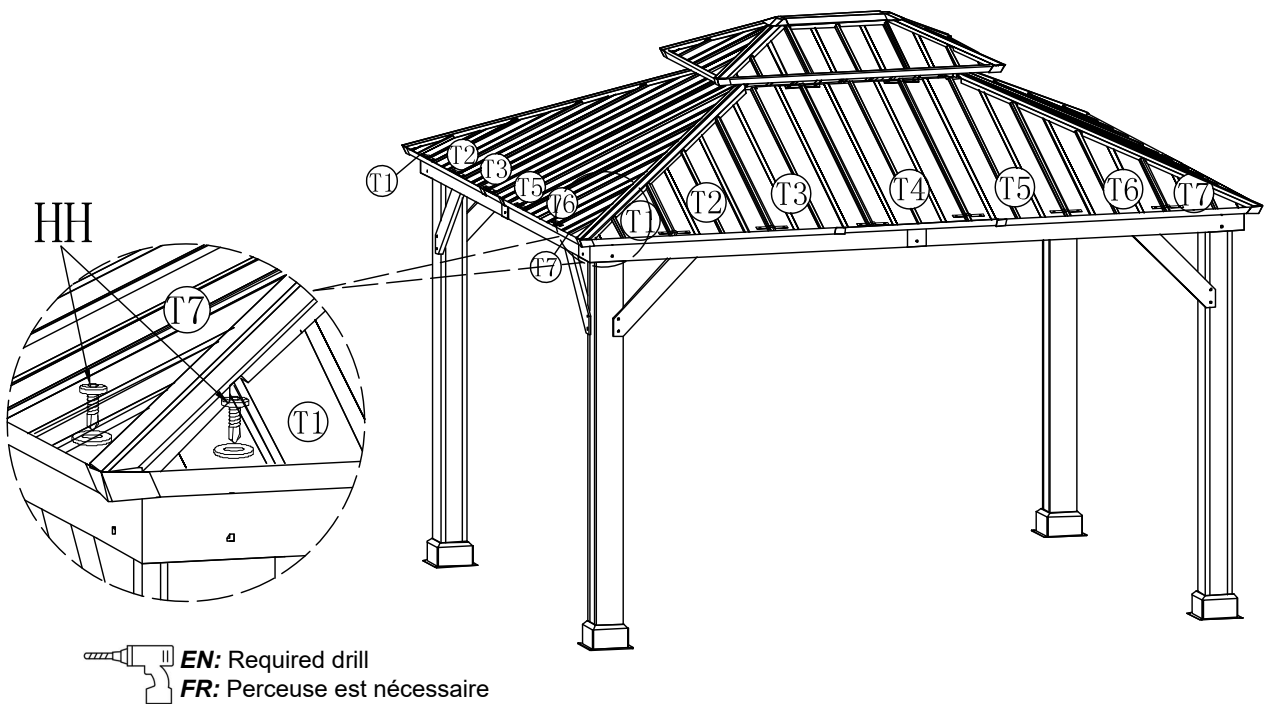

EN: Fix the corners of the big roof cover plates by using bolts **HH**.

FR: Fixez les coins des plaques de couverture du grand toit avec les boulons **HH**.

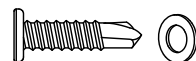

M6*15

HH 8X

<35>

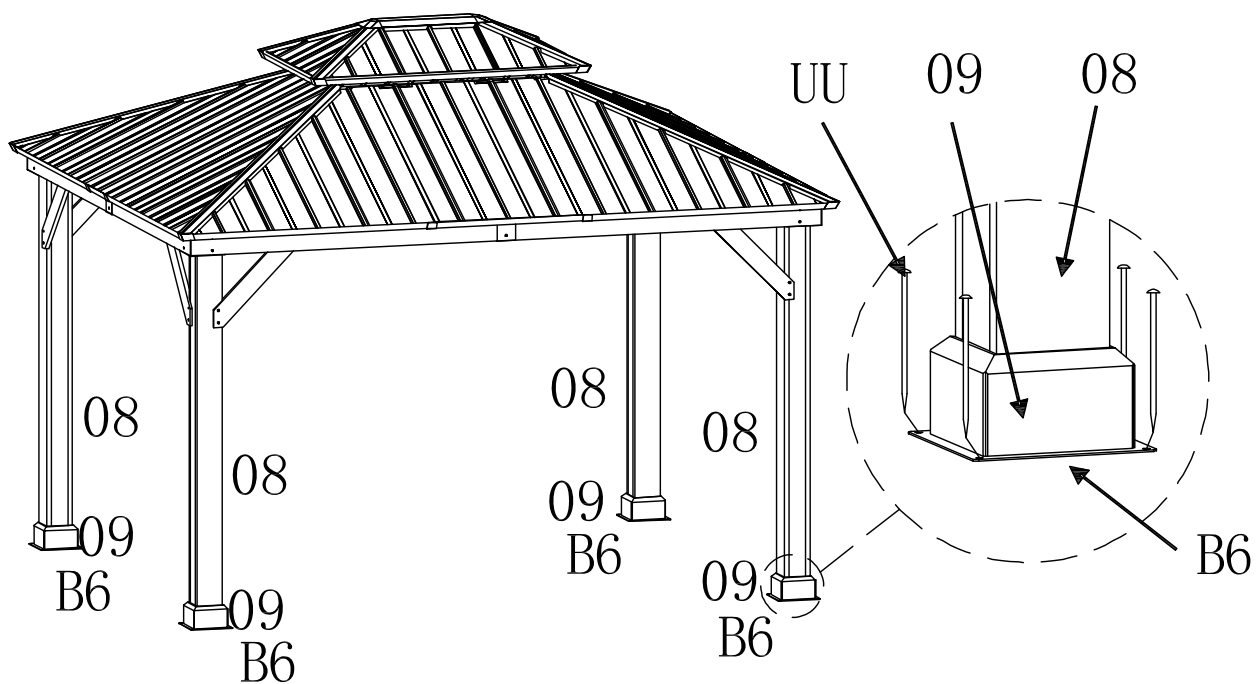

EN: Fix base **B6** of post **08** on the ground by using stake **UU**.

FR: Fixer la base **B6** du poteau **08** au sol à l'aide du piquet **UU**.

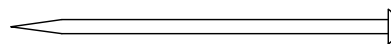

Ⓢ 16X

EN

Care and Maintenance

1. Our steel components for garden accessories and furniture are treated with rust inhibiting paint that protects it from rusting. However, due to the nature of steel, surface oxidation (rusting) will occur once these protective coatings are scratched. This is not a defect and thus not covered by the warranty.
2. To minimize this condition, we recommend care when assembling & handling the product to prevent scratching the paint. Should any scratching or damage occur, we recommend immediate touch-up with rust inhibiting paint.
3. Surface rust can also be easily removed with a very light application of common cooking oil. If surface oxidation (rusting) occurs and if no measure is taken to prevent this, the oxidation may start dripping on to deck or patio and caused damaging stains, which may be difficult to remove. This can be prevented if the above-mentioned measures are taken to keep the product from oxidizing.
4. Use damp cloth to wipe off the stains as quickly as possible.
5. If necessary, wash with a mild solution of soap and water; rinse thoroughly and dry completely.
6. Periodically check and ensure that all bolts are well-tighten during use.

FR:

Maintenance préventive et corrective

1. Les composants en acier des meubles et accessoires de jardin sont traités avec une peinture antirouille pour les protéger de la rouille. Cependant, en raison de la nature de l'acier, une oxydation de surface (rouille) se produira une fois ces revêtements protecteurs rayés. Ce qui n'est pas un défaut et n'est donc pas couvert par la garantie.
2. Afin de minimiser l'occurrence de cette situation, nous vous recommandons de veiller lors de l'assemblage et de la manipulation du produit à éviter de rayures sur la peinture. En cas de rayures ou de dommages, il est recommandé de les réparer immédiatement par une peinture antirouille.
3. La rouille de surface sera également facilement éliminée avec une très légère application d'huile de cuisson courante. Si une oxydation de surface (rouille) se produit et qu'aucune mesure n'est prise, l'oxydation peut commencer à s'égoutter sur la terrasse ou le patio, provoquant des taches dommageables qui seront difficiles à enlever. Les mesures mentionnées ci-dessus sont pour éviter l'oxydation du produit.
4. Nettoyez les taches dès que possible avec un chiffon humide.
5. Si nécessaire, lavez-le avec une solution d'eau et de savon doux, puis le rincez et séchez complètement.
6. Vérifiez périodiquement et assurez-vous que tous les boulons sont serrés pendant l'utilisation.



Call us First !
DO NOT RETURN TO STORE

For immediate help with assembly or product information

call our number:

888-328-5111

Or E-mail:

service@mondawe.com

Our staff is ready to provide assistance

M-F 9:00 AM to 5:00 PM EST