

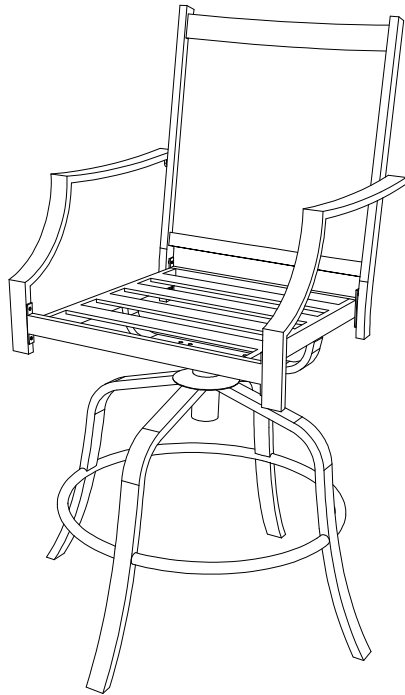

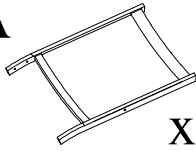

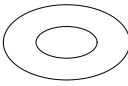



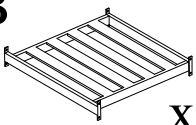
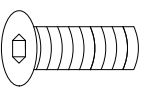

ASSEMBLE INSTRUCTION

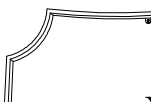

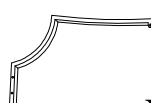
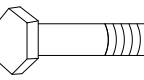
A  x1	F  Ø6.5*1.0 x10	K  5/16" x4
B  x1	G  1/4"x16 x10	L  5/16" x4
C  x1	H  x4	M  x4
D  x1	I  5/16"x43 x4	N  x1
E  x1	J  x2	O  x1
		P  x1

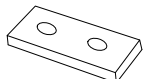
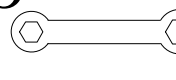

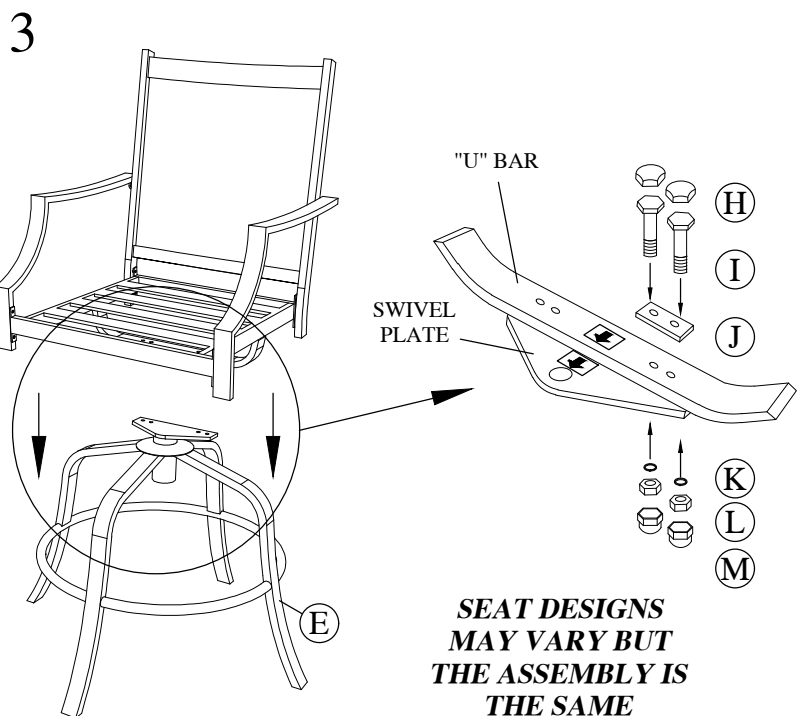
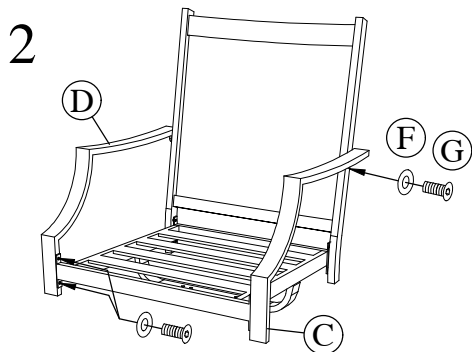
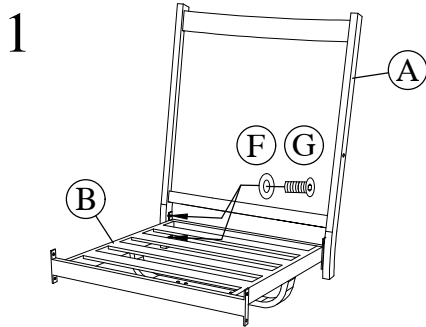
1. Fix all the screws in place, without tightening them first.
2. After confirming the position of all the screws, tighten the screws and nuts.