

# 10' × 14' Metal Patio Gazebo

## ASSEMBLY MANUAL

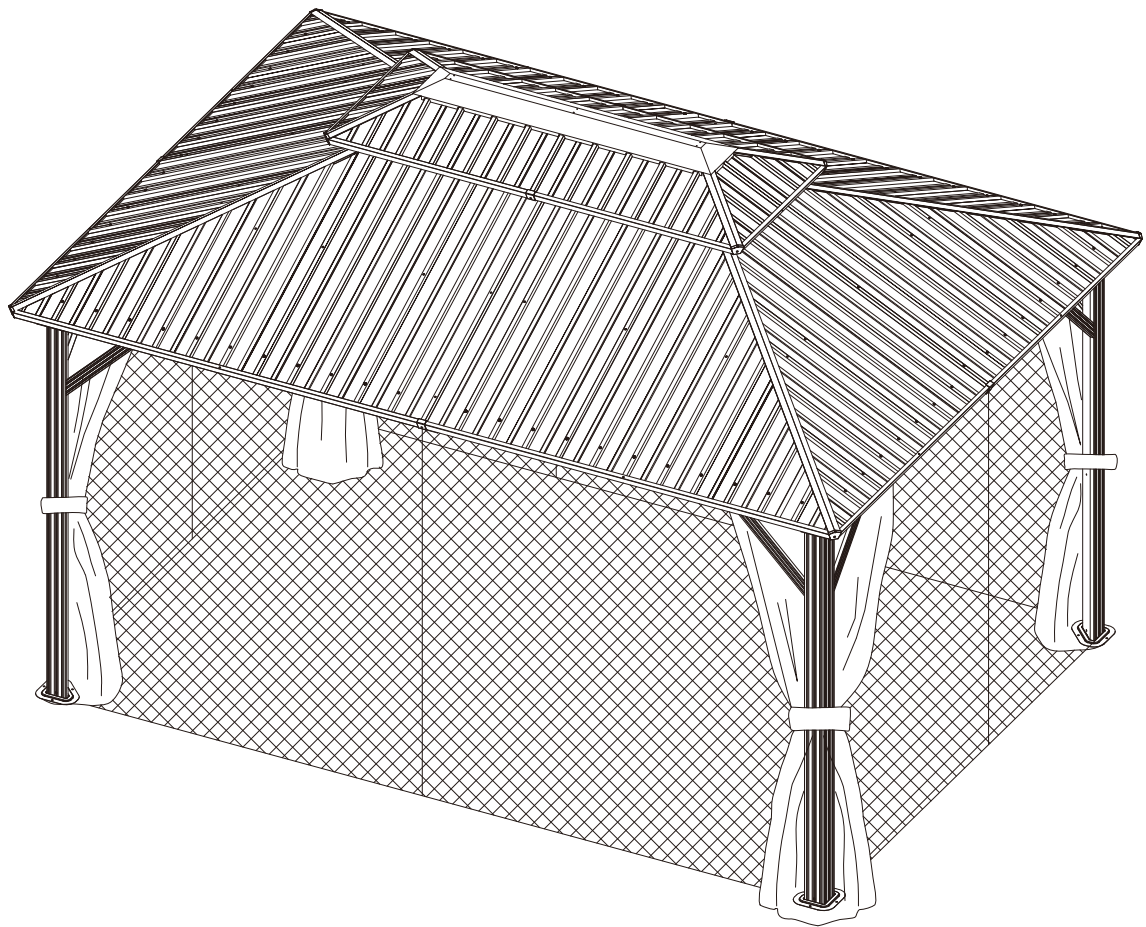

MODEL# : LGMF1597

Missing part? Damaged? Contact us via email at  
[service@domioutdoorliving.com](mailto:service@domioutdoorliving.com)

[www.domioutdoorliving.com](http://www.domioutdoorliving.com)

© Copyright 2022–2024 domi LLC. | All Rights Reserved.

# Pre-assembly



1. Two or more people are required for assembly.



2. You will need one or more stepladders.



3. Wearing protective gloves is recommended.



4. You may need a safety hat.



5. Please use a Phillips screw driver.



6. For ease of construction, you may need a drill.



7. You may need a safety goggle.



8. Do not fully tighten screws prior to complete assembly.

## Warning & Attention

-Try to assemble this product on the flat ground, otherwise it is difficult to carry out;

-It would be much easier to assemble the product with three or more people;

-After assembly, please check whether all screws are tightened, to prevent parts from falling apart.

▲ Use bolts to secure the frame to the ground to against the strong wind.

1

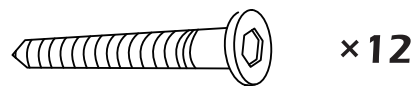
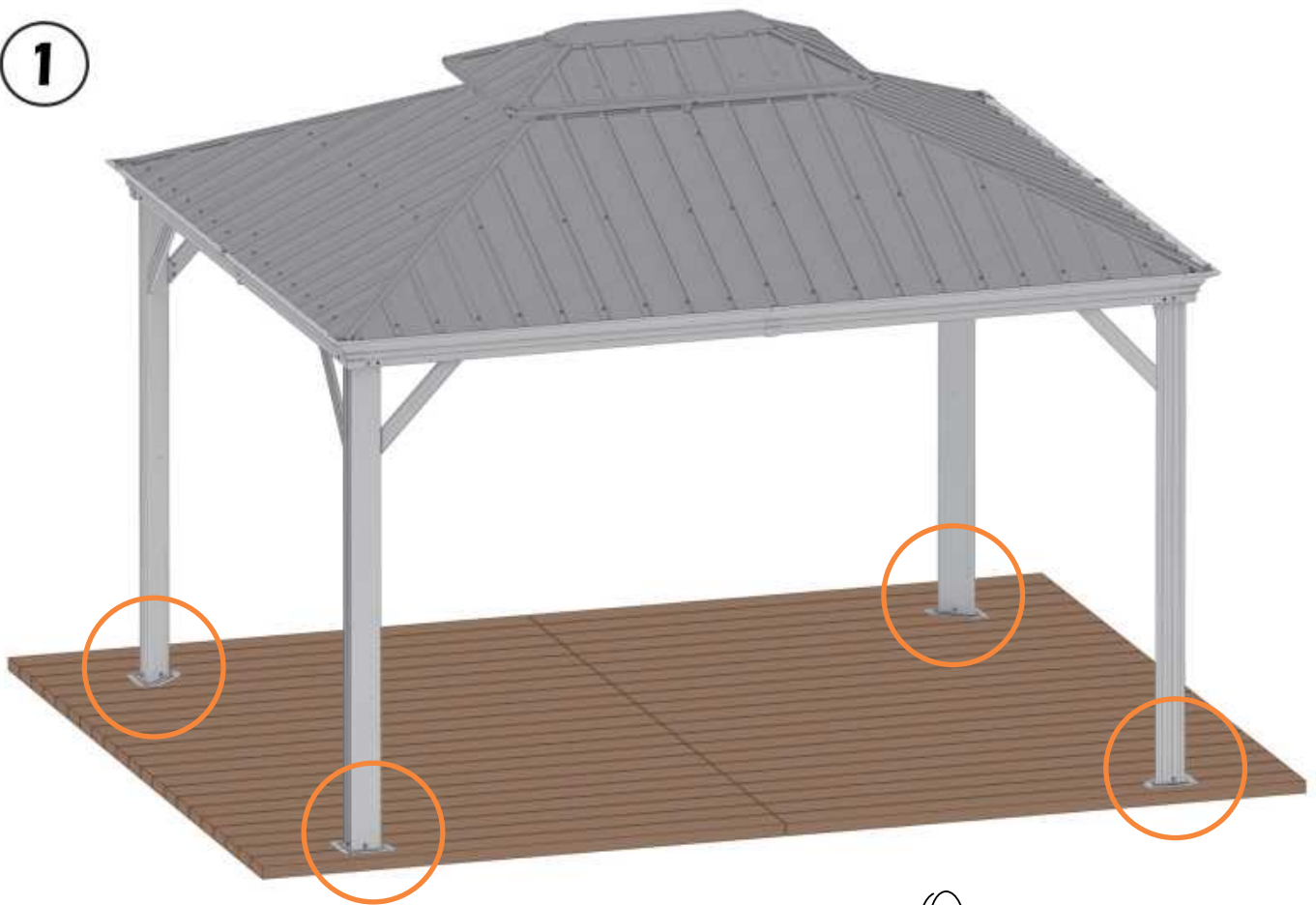

If the deck is hard wood and the depth of it is over 3 inch, you can use **5/16 in. ×4 in. Structural Wood Screw** to mount the gazebo.

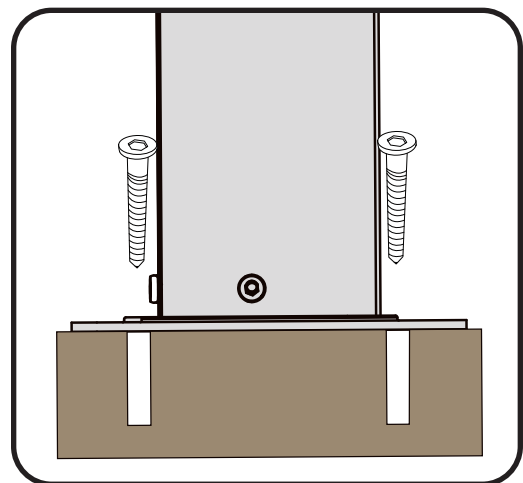
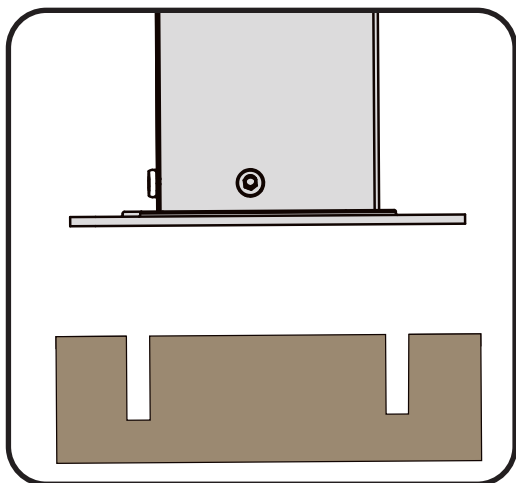

2

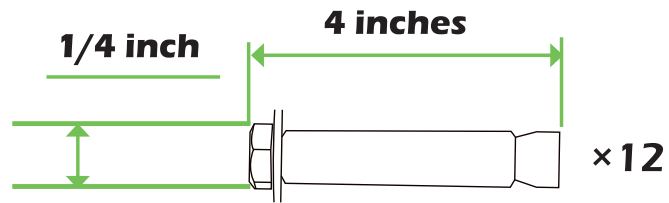
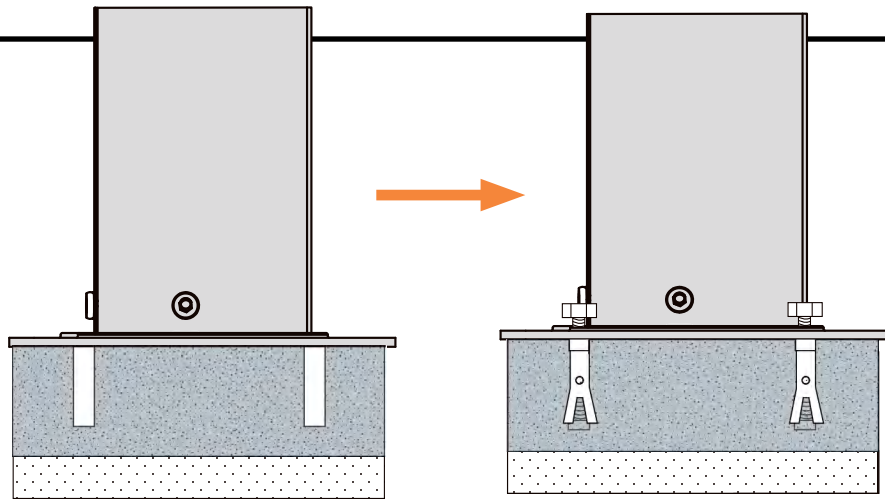

If the ground is concreted and the depth of it is over 3 inch, you can use 1/4 inch expansion bolts to mount the gazebo

3

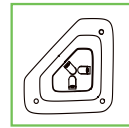
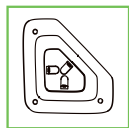
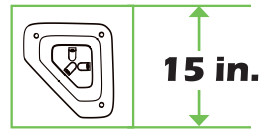
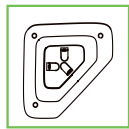

Or you can make a concrete footing for gazebo, **15×15×15 inches** is recommended. use expansion bolts to mount the pergola like ② shows.

**IMPORTANT:**  
Anchor is not recommended

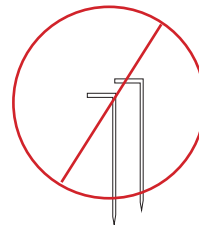

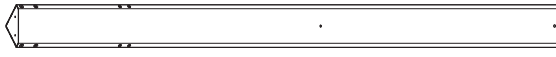

A 4x Pole

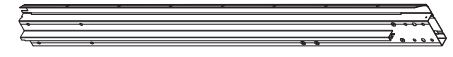

C 2x Beam

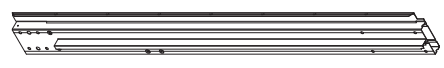

C1 2x Beam

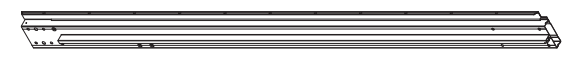

D 2x Beam



D1 2x Beam



E 4x Corner Roof Bar



E1 4x Corner Roof Bar Connector

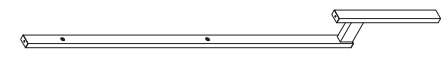

E2 4x Roof Bar



F 4x Solidfying Bar



G 2x Solidfying Bar

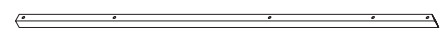

G1 2x Solidfying Bar



H 2x Finishing Bar

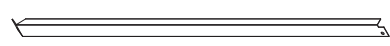

H1 2x Finishing Bar

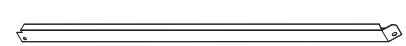

H2 2x Finishing Bar



J 2x Finishing Bar



J1 2x Finishing Bar

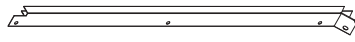

J2 2x Finishing Bar



K 2x Finishing Bar



K1 2x Finishing Bar



K2 2x Finishing Bar



K3 2x Finishing Bar

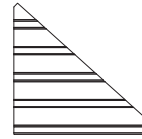

L1 2x Roof Panel

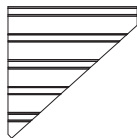

L2 2x Roof Panel

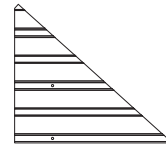

M1 2x Roof Panel

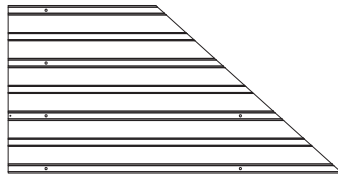

M2 2x Roof Panel



M3 2x Roof Panel



M4 2x Roof Panel

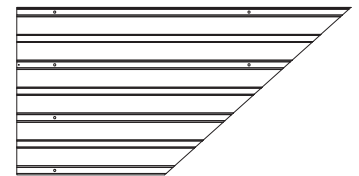

M5 2x Roof Panel

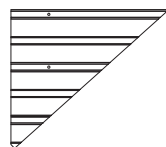

M6 2x Roof Panel

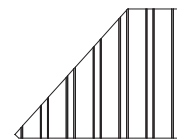

N1 2x Roof Panel

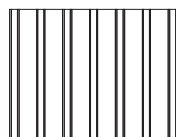

N2 4x Roof Panel

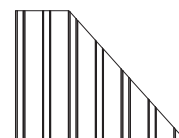

N3 2x Roof Panel



**P1** 2x Roof Panel

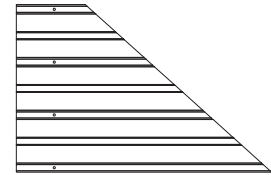

**P2** 2x Roof Panel

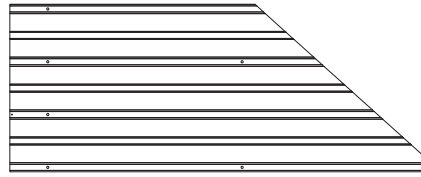

**P3** 2x Roof Panel

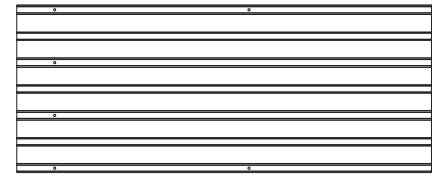

**P4** 4x Roof Panel

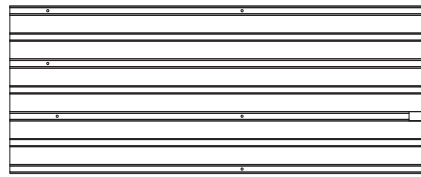

**P5** 2x Roof Panel

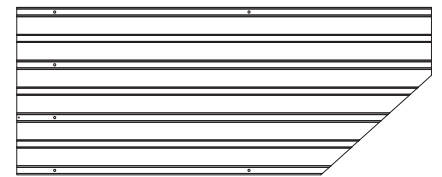

**P6** 2x Roof Panel

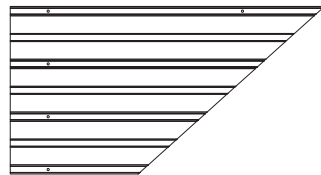

**P7** 2x Roof Panel

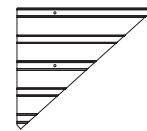

**P8** 2x Roof Panel

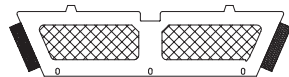

**Q** 2x Net Frame

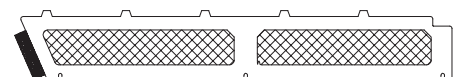

**Q1** 2x Net Frame

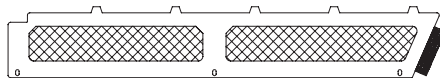

**Q2** 2x Net Frame



**B** 4x Base



**B1** 8x Joint Cover



**B2** 8x Joint Cover

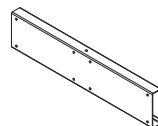

**C2** 4x Union Bar

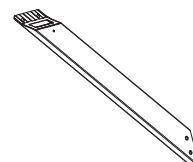

**R** 4x Corner Solidifying Bar

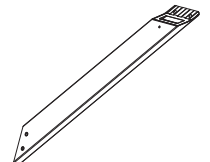

**R1** 4x Corner Solidifying Bar

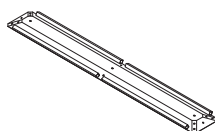

**S** 1x Inside Roof Connector

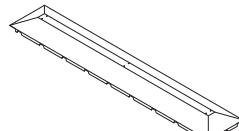

**S1** 1x Outside Roof Connector

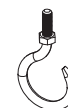

**T** 3x J-Hook

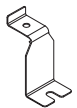

**T1** 4x Bracket

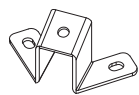

U 4x Bracket

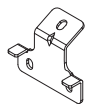

U1 4x Bracket



U2 4x Bracket

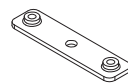

U3 4x Joint Cover



V 112x Hook

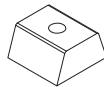

W 100x Spacer



X 4x Bracket

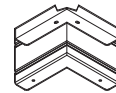

X1 4x Corner Cover



X2 6x Finishing End



X3 12x Finishing End



Y 4x Solid Sidewall

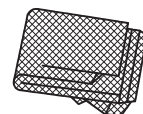

Y1 4x Mosquito Sidewall



Z 60x Plastic Bracket



Z1 4x Plastic Bracket



Z2 4x Plastic Bracket



Z3 2x Plastic Bracket



Z4 2x Plastic Bracket

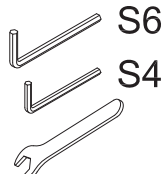

1 1x



ST6.3x15

2 12x



ST5x16

3 24x

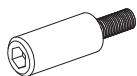

M6x15

4 32x



M6

5 104x



M5x12

6 16x



M6x10

7 20x



M6x16

8 188x

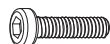

M6x25

9 8x



M6x28

10 72x

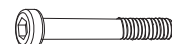





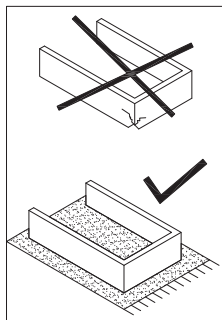

M6x50

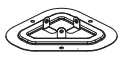
12 20x







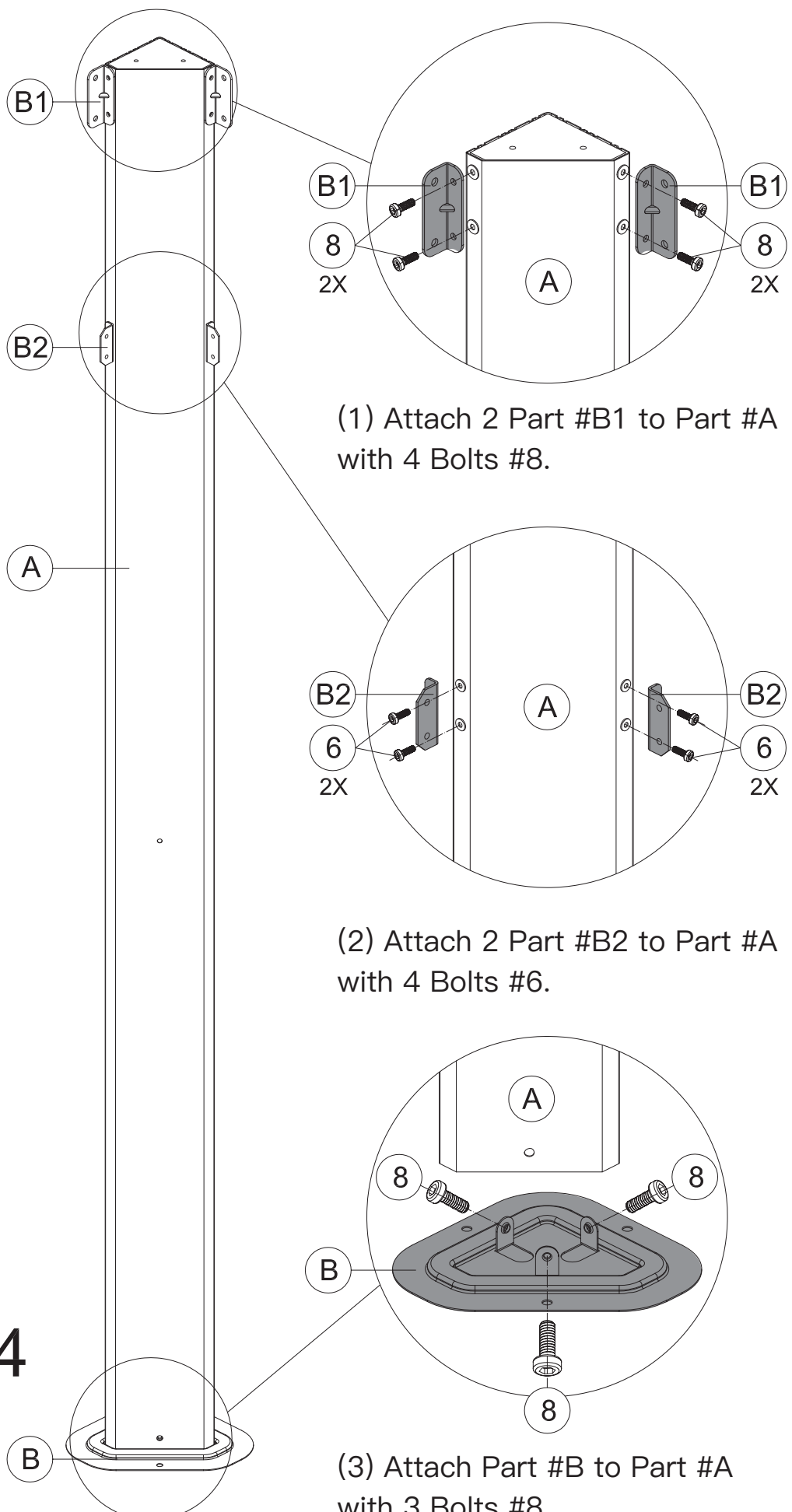

	<b>A</b> 4x
	<b>B</b> 4x
	<b>B1</b> 8x
	<b>B2</b> 8x
	<b>1</b> 1x S4
	<b>6</b> 16x M5x12
	<b>8</b> 28x M6x16
<b>6</b>	

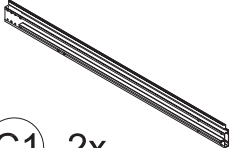

**X4**  
**(4)** Repeat the above procedures to assemble the other 3 Part #A.

-  **C** 2x
-  **C1** 2x
-  **C2** 2x
-  **X** 2x
-  **1** 1x
-  **8** 20x  
M6x16

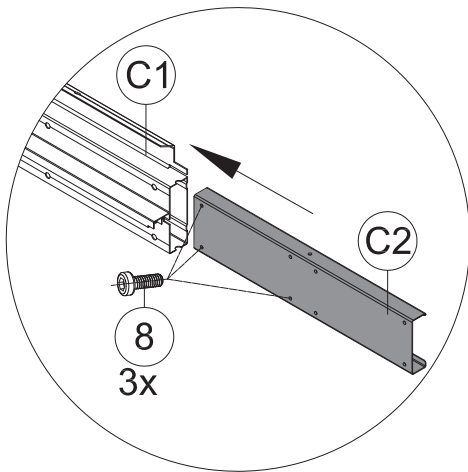

(1) Insert Part #C2 into Part #C1 and secure with 3 Bolts #8.

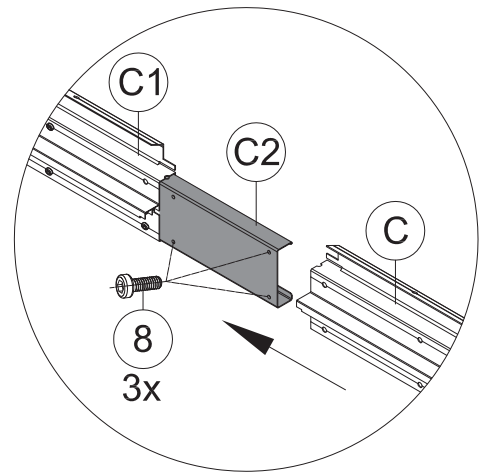

(2) Insert the other side of Part #C2 into Part #C and secure with 3 Bolts #8.

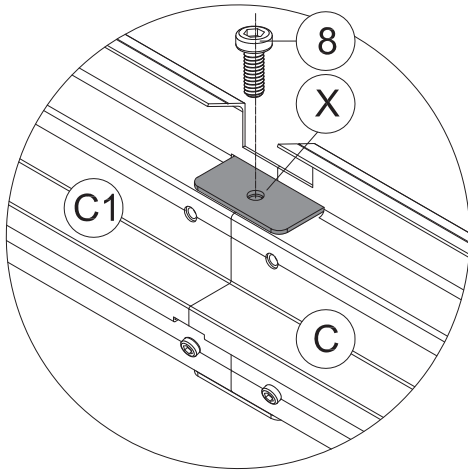

(4) Insert Part #X into the beam.

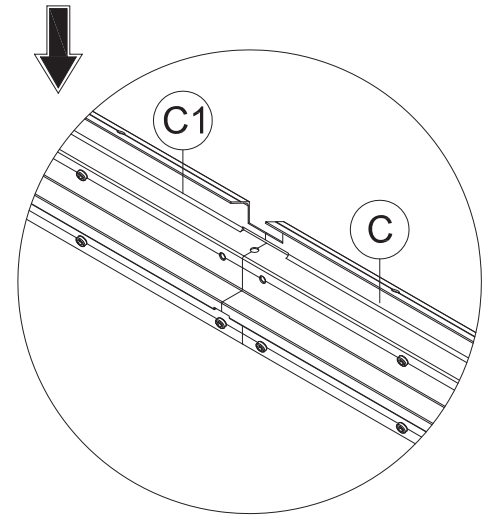



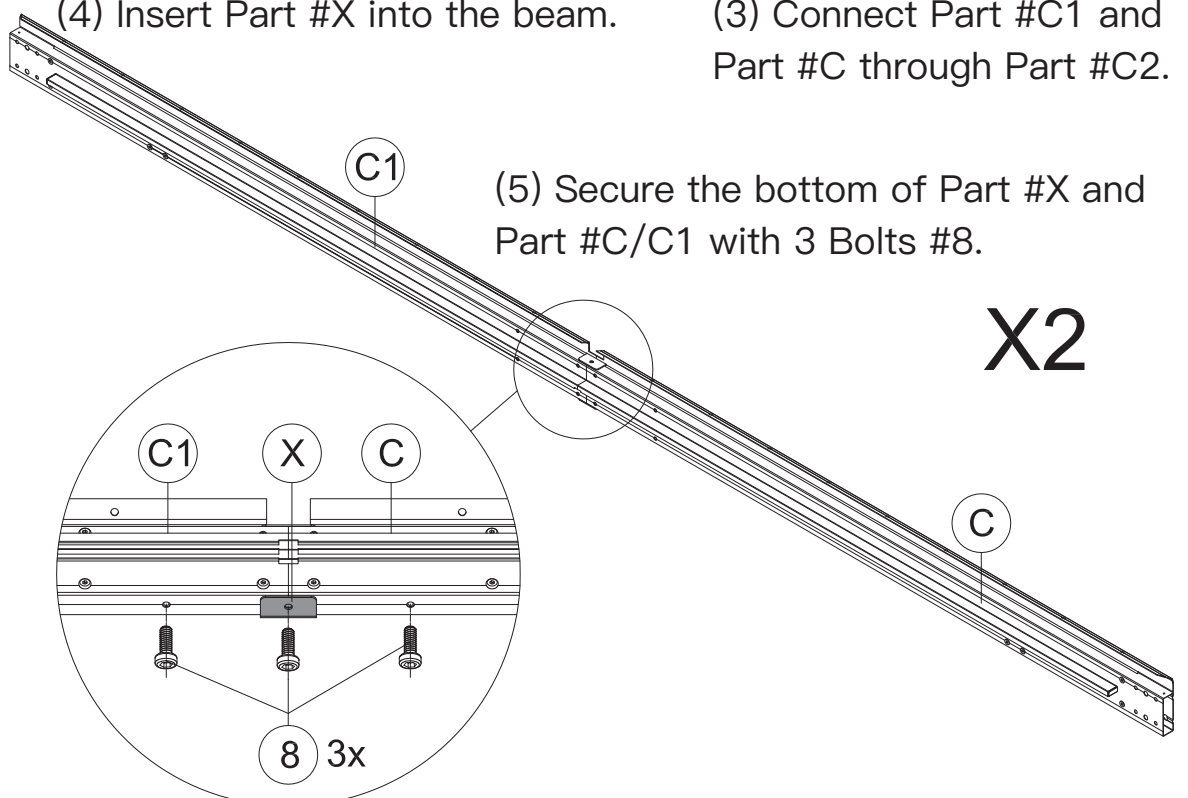

(3) Connect Part #C1 and Part #C through Part #C2.

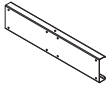
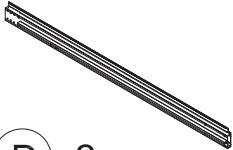
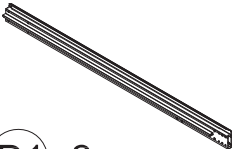

(5) Secure the bottom of Part #X and Part #C/C1 with 3 Bolts #8.

**X2**

(6) Repeat the above procedures to assemble the other Part #C and Part #C1.

-  **C2** 2x
-  **D** 2x
-  **D1** 2x
-  **X** 2x
-  **1** 1x
-  **8** 20x
- M6x16**
- 8**

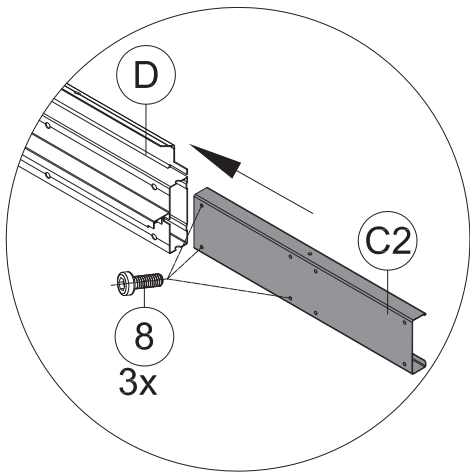

(1) Insert Part #C2 into Part #D, and secure with 3 Bolts #8.

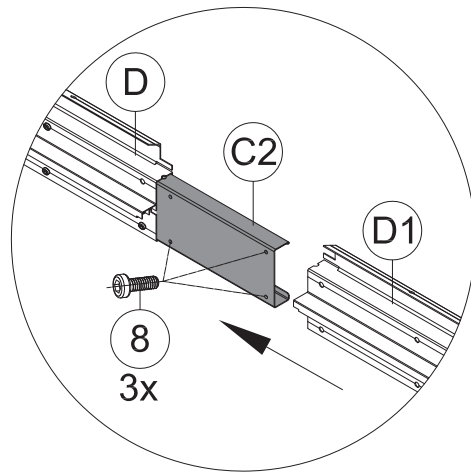

(2) Insert the other side of Part #C2 into Part #D1 and secure with 3 Bolts #8.

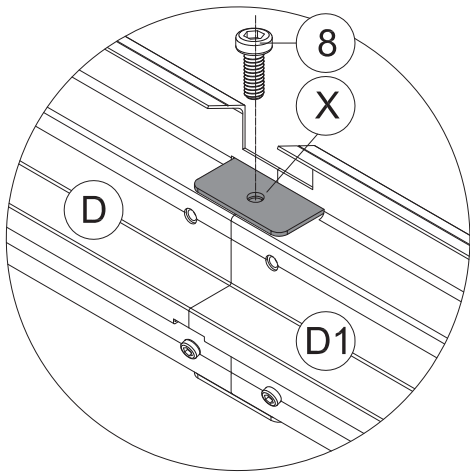

(4) Insert Part #X into the beam and secure with 1 Bolt #8.

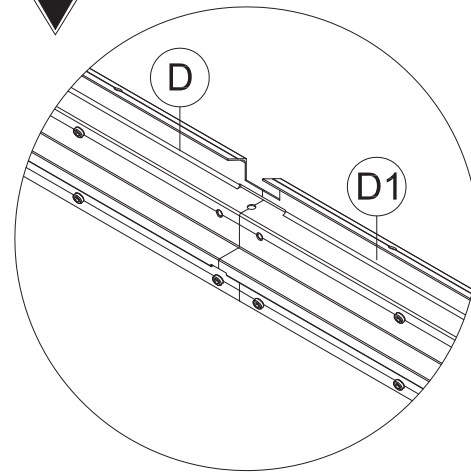

(3) Connect Part #D and Part #D1 through Part #C2.

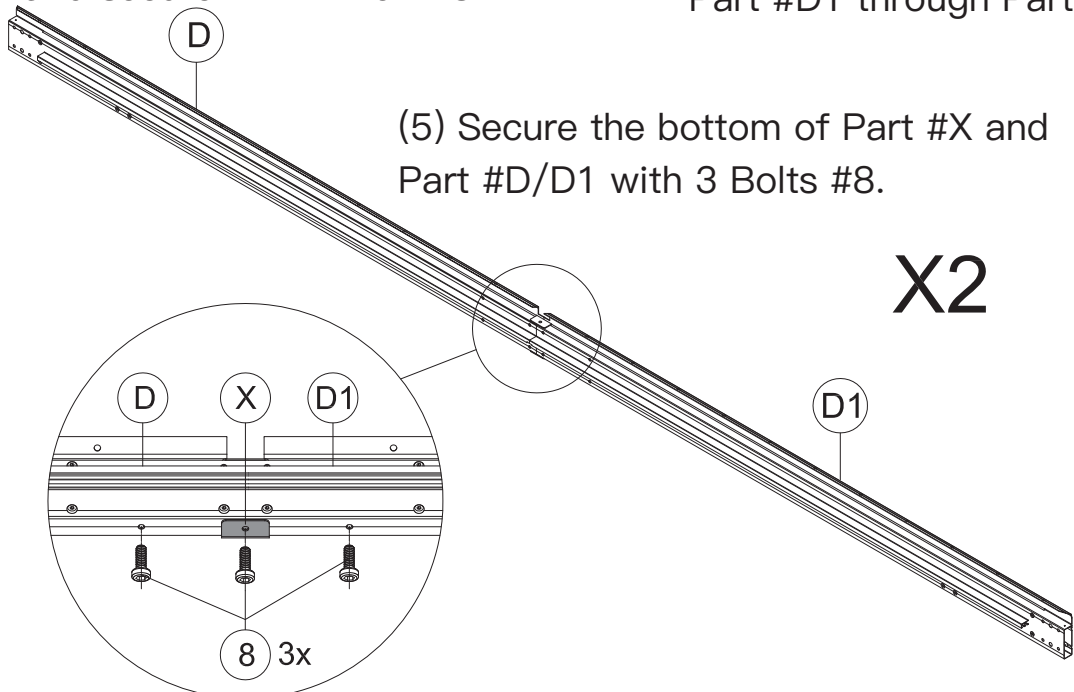

(5) Secure the bottom of Part #X and Part #D/D1 with 3 Bolts #8.

(6) Repeat the above procedures to assemble the other Part #D and Part #D1.



1 1x

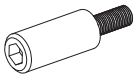

M6x15

4 32x

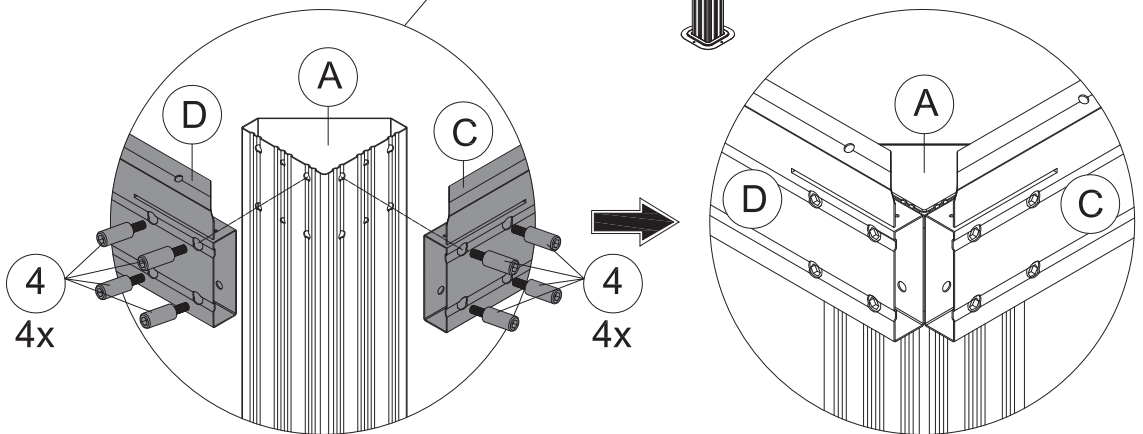
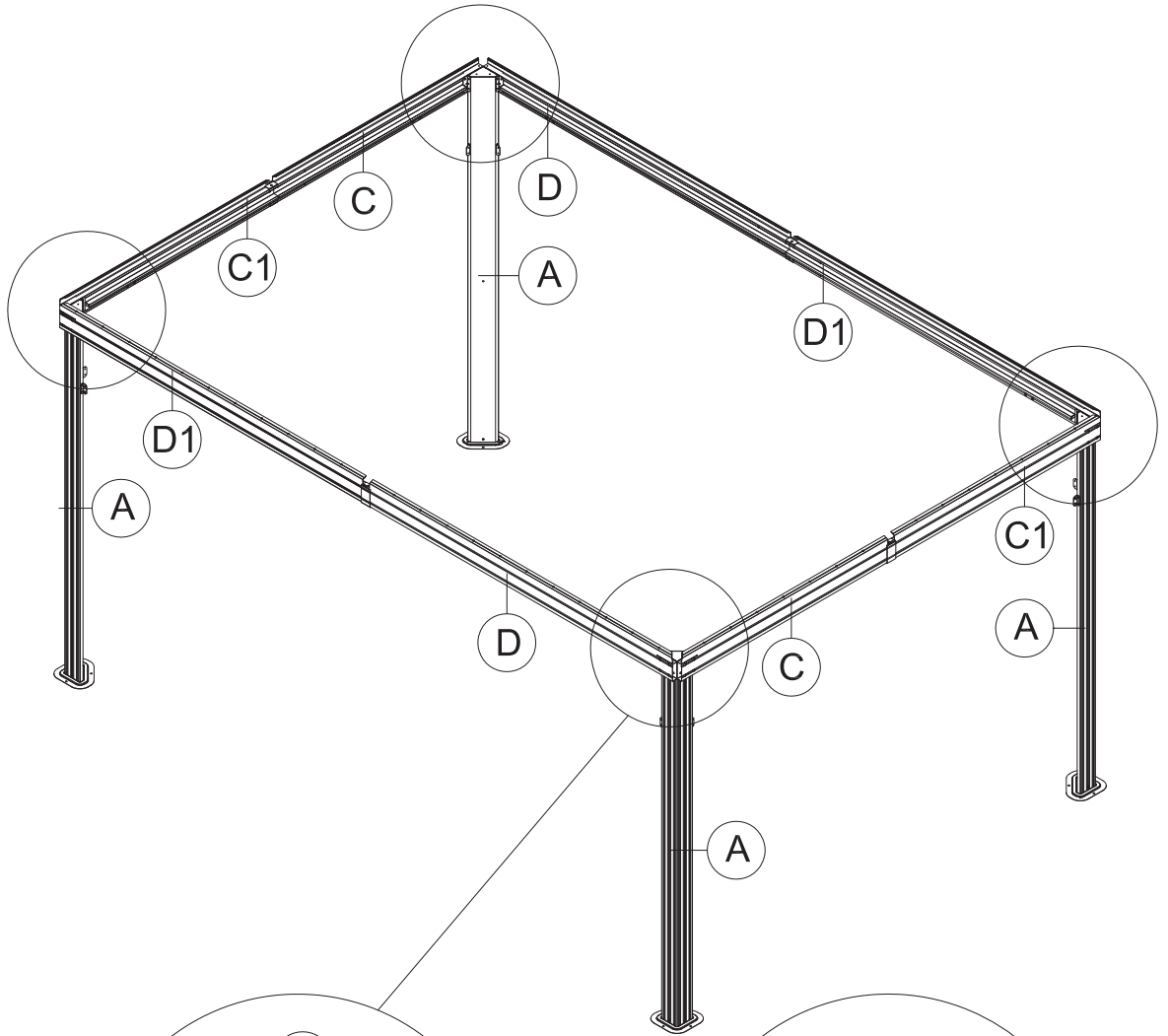

- (1) Connect Part #C/C1 and #D/D1 to Part #A with 8 Bolts #4.  
(From Outside)
  - (2) Repeat the above procedures to assemble the other 3 corners.
- ▲ Please don't tighten all bolts.

✓ S4

1 1x



M6x16

8 16x

(1) Connect Part #C/C1 and #D/D1 to Part #A with 4 Bolts #8.  
(From Inside)

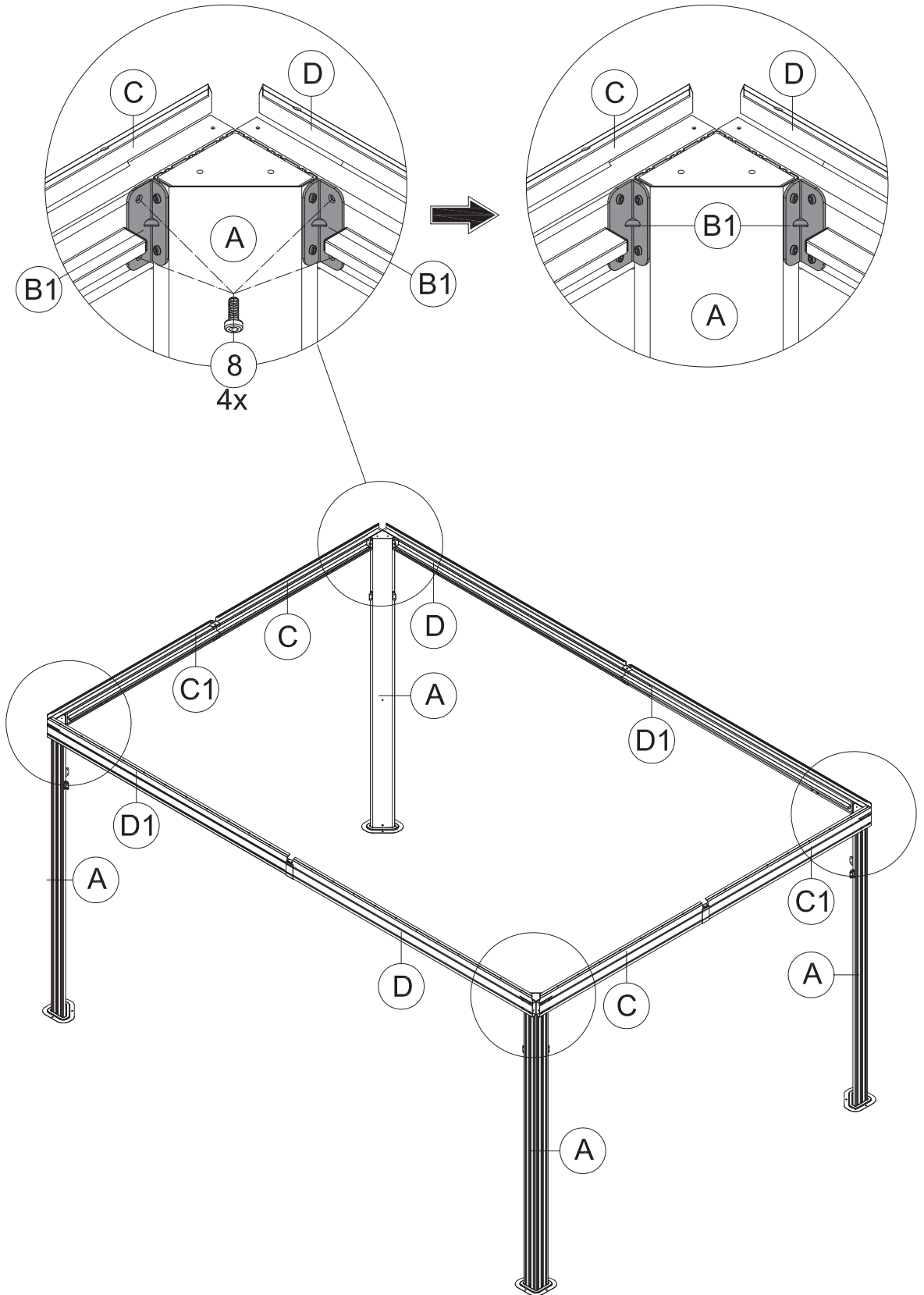

(2) Repeat the above procedures to assemble the other 3 corners.  
▲ Please don't tighten all bolts.

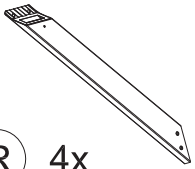

R 4x

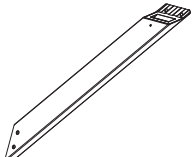

R1 4x



1 1x



M6x16

8 32x

(1) Affix Part #R and Part #R1 to the frame with 8 Bolts #8.

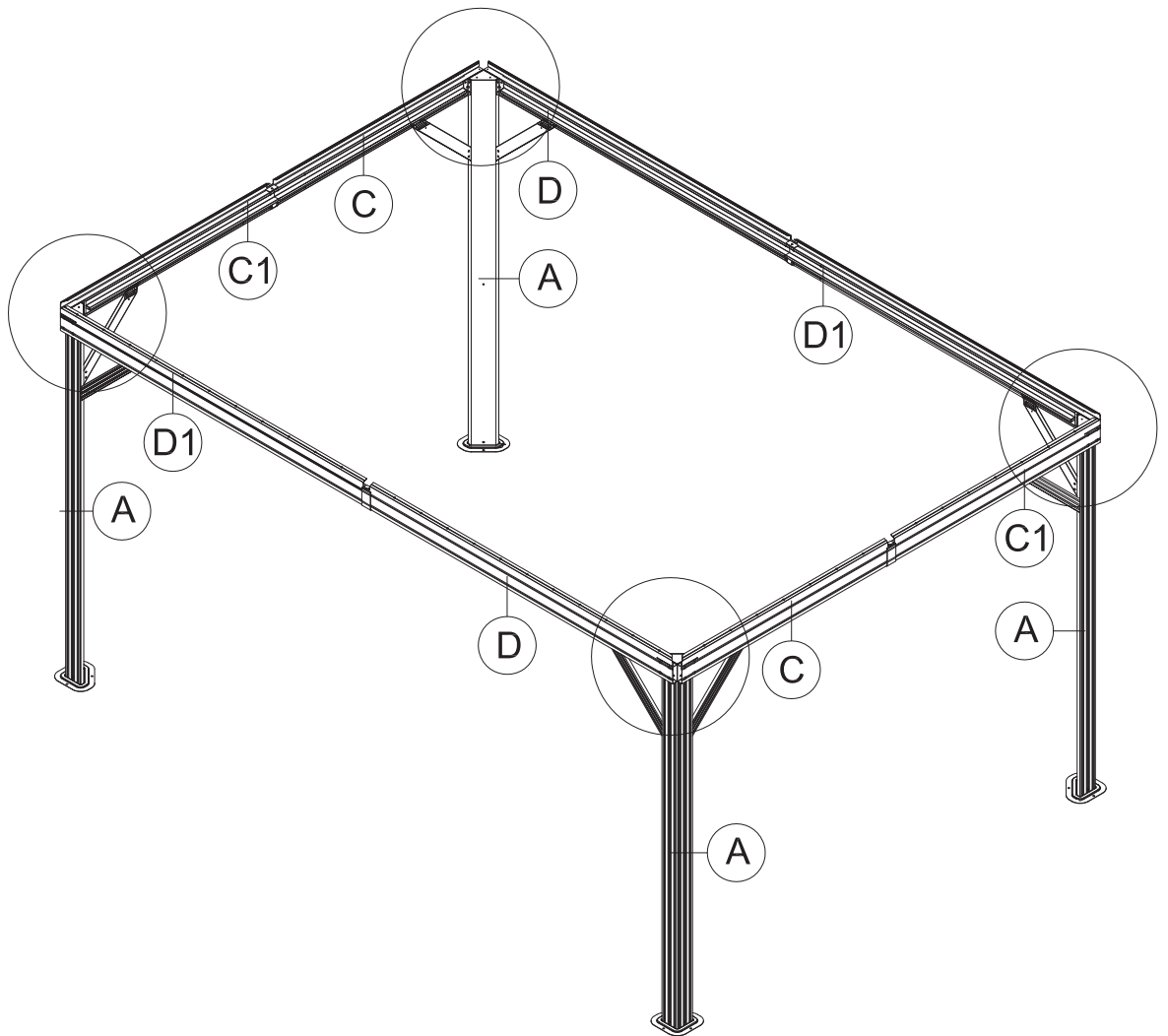
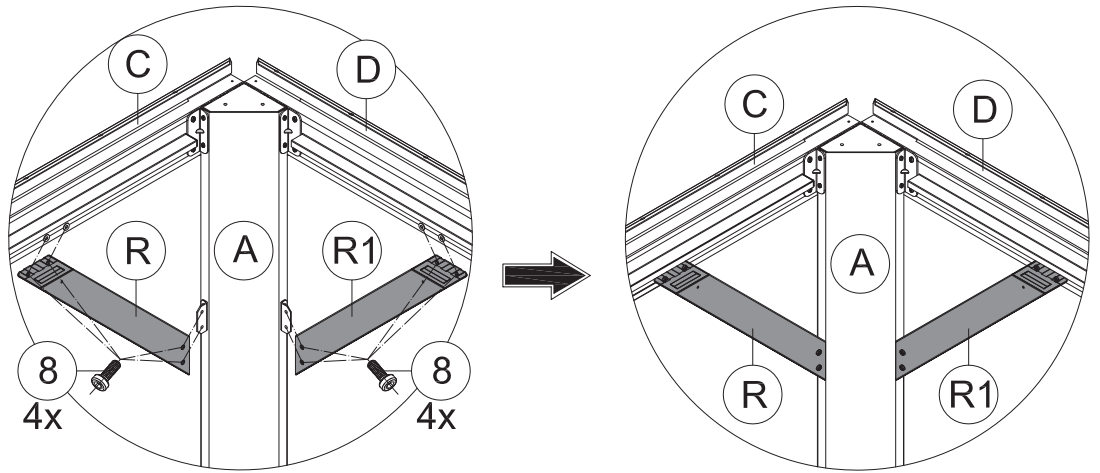

(2) Repeat the above procedures to assemble the other 3 corners.

▲ Please don't tighten all bolts.

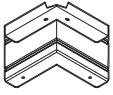

X1 4x



ST5x16

3 16x

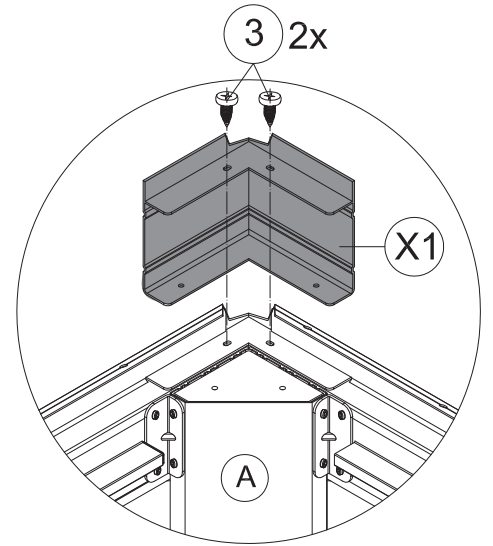
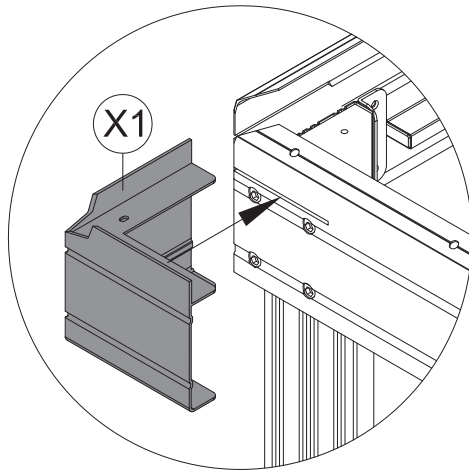

(1) Cover the corner with Part #X1. (2) Secure with 2 Self-tapping Screws #3. (from top to bottom)



(3) Secure with 2 Self-tapping Screws #3. (from bottom to top)

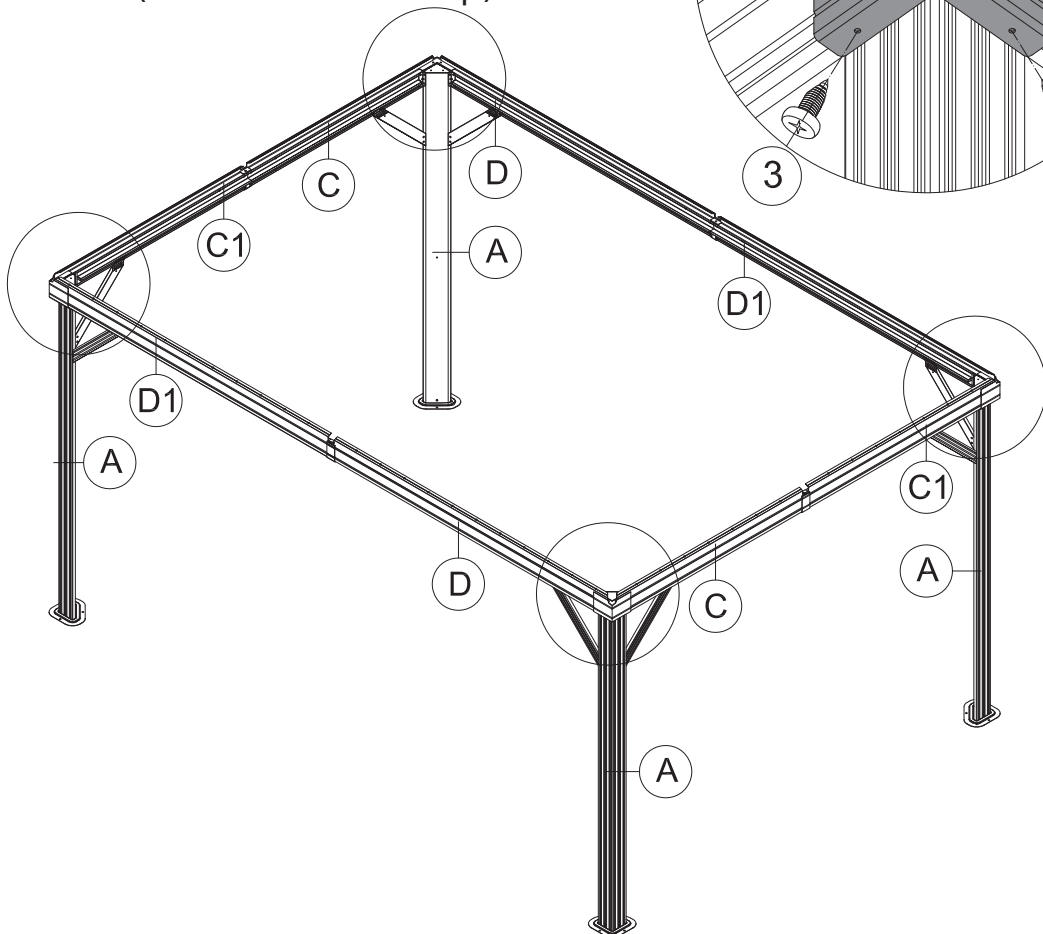
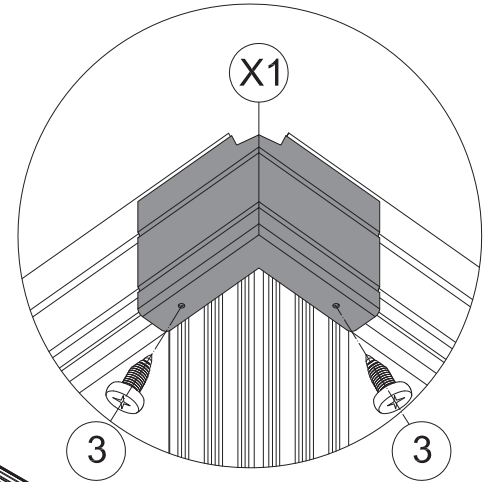

(4) Repeat the above procedures to assemble the other 3 corners. ▲ Tighten all bolts.

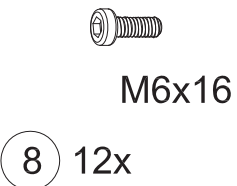
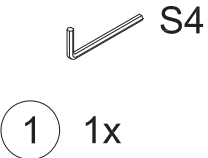
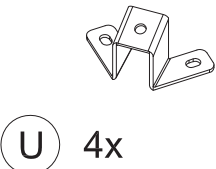
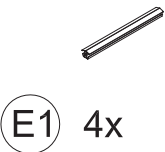
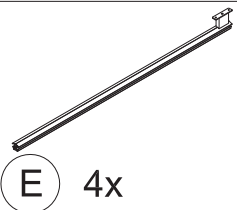

**Assemble the 4 Corner Roof Bars:**

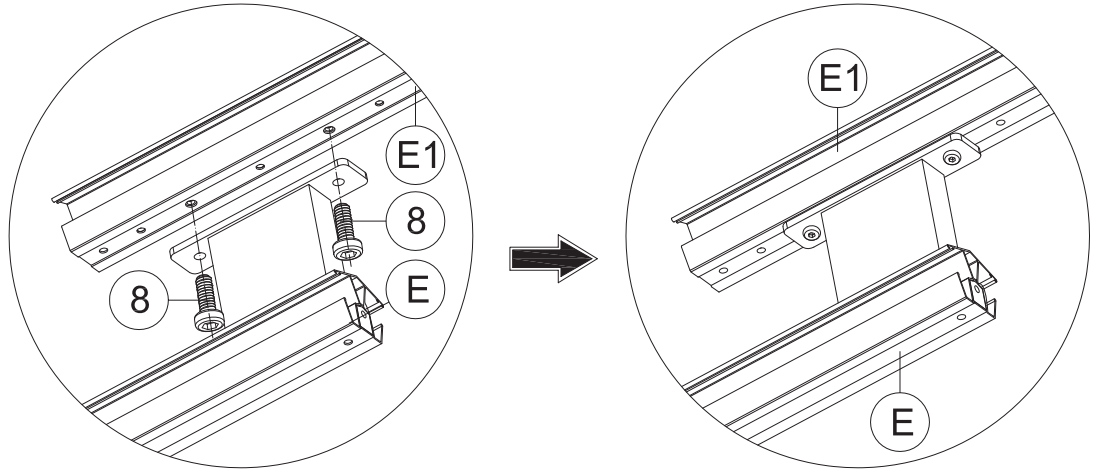

(1) Connect Part #E1 and Part #E with 2 Bolts #8 .

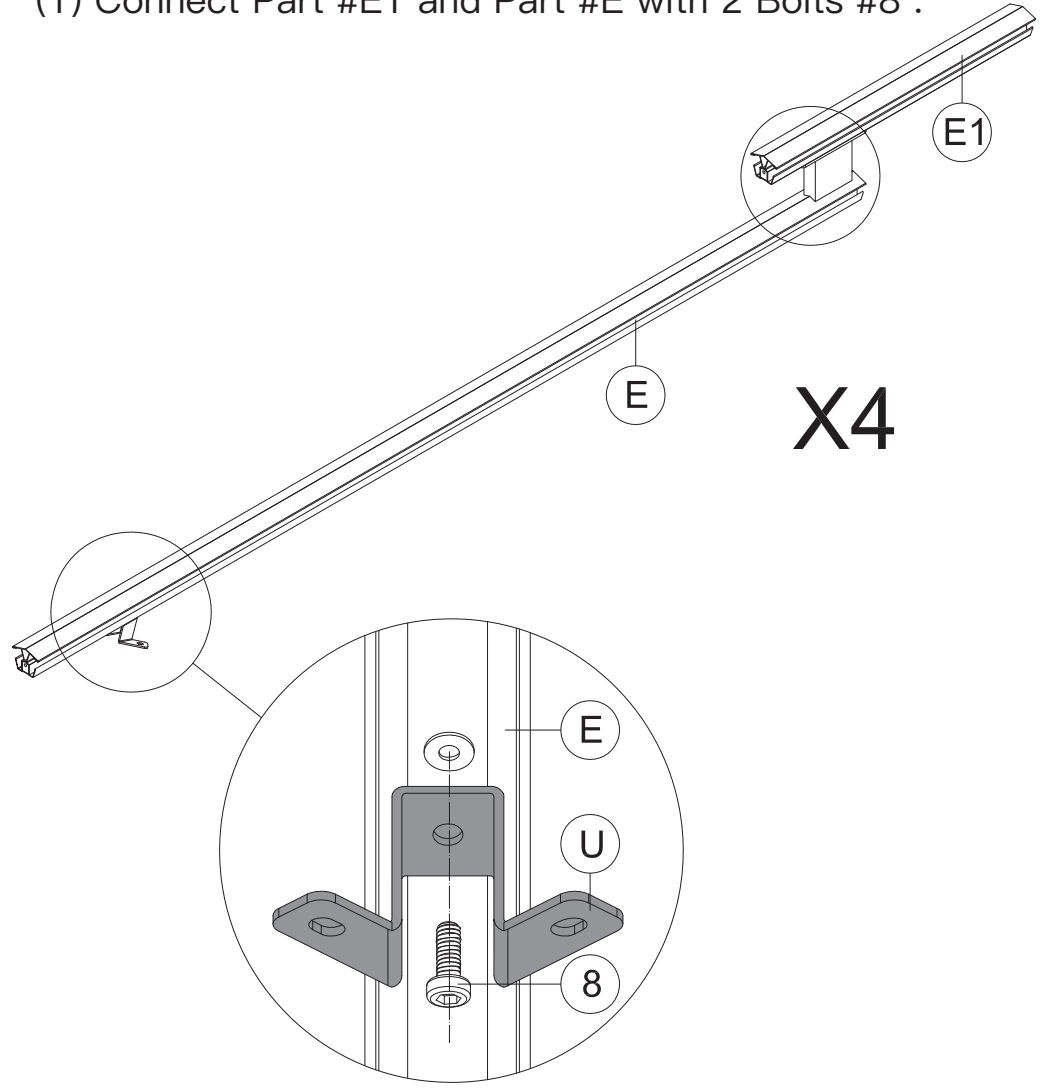

(2) Attach Part #U to Part #E with Bolt #8 .

(3) Repeat the above procedures to assemble the other 3 Corner Roof Bars.



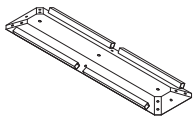

S 1x



1 1x



M6x16

8 16x

Please have a freestanding ladder ready at the center of the gazebo.

(1) Place 4 Part #E1 on the 4 corners of Part #S.

Secure with 8 Bolts #8 (from bottom to top)

**ATTENTION:** You can also finish this step on the ground and then lift 4 corner roof bar and inside roof connector to the top together. (Need 2 people and 2 ladder)

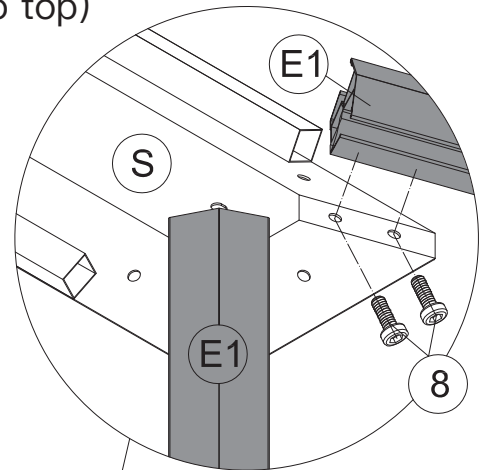

Outside View

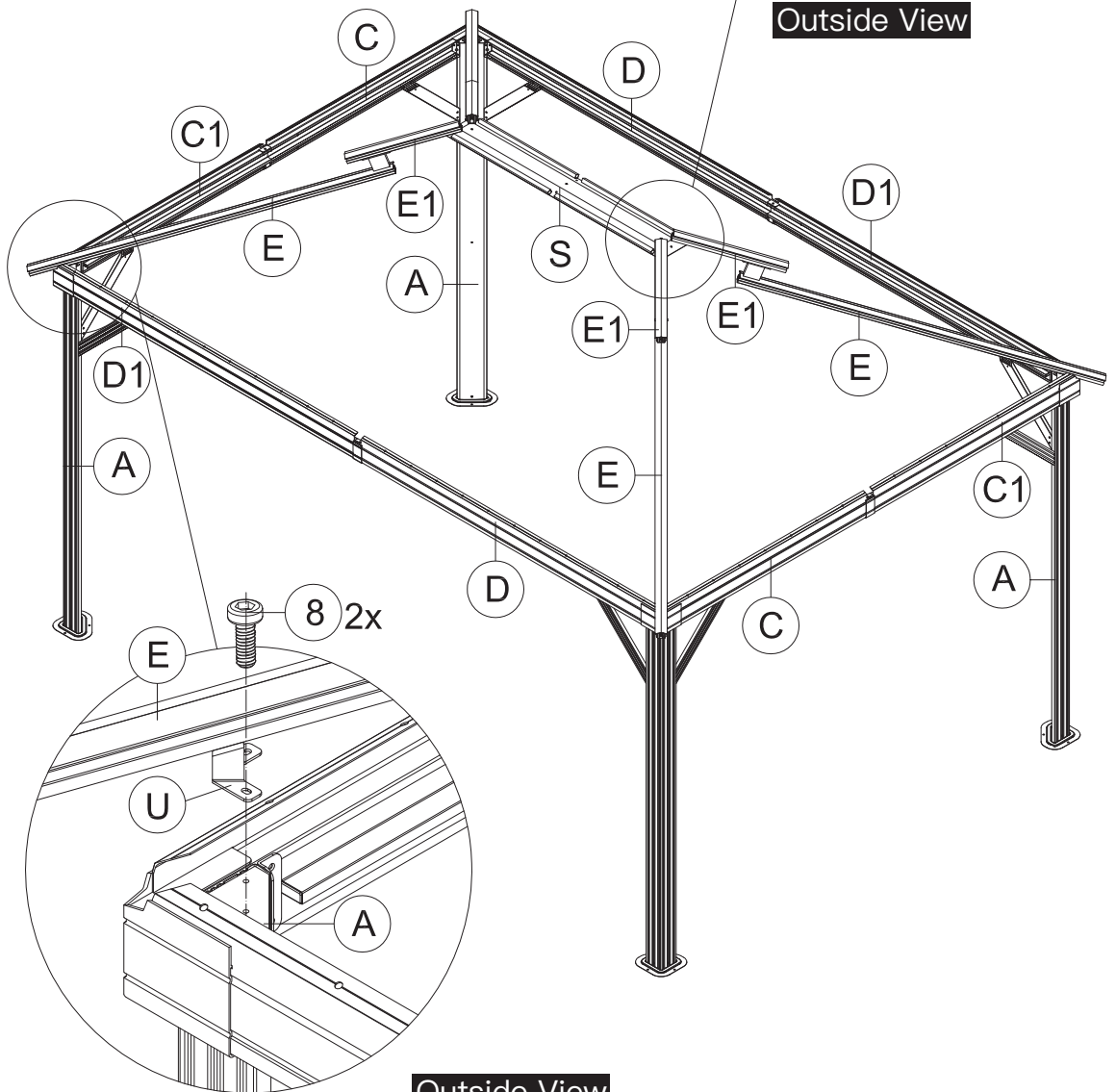

Outside View

(2) Place 4 Part #E on 4 Part #A; Secure with 8 Bolts #8.

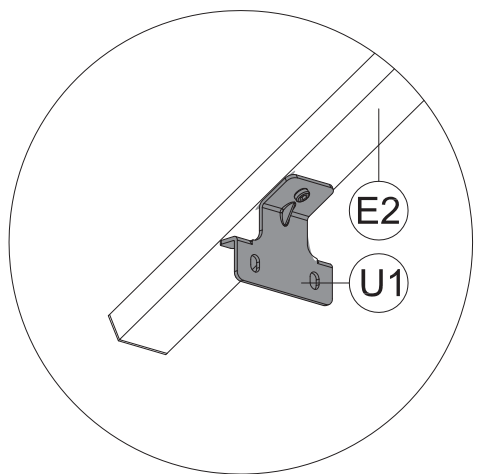
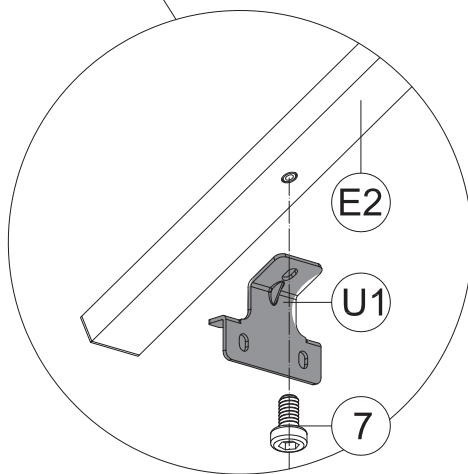
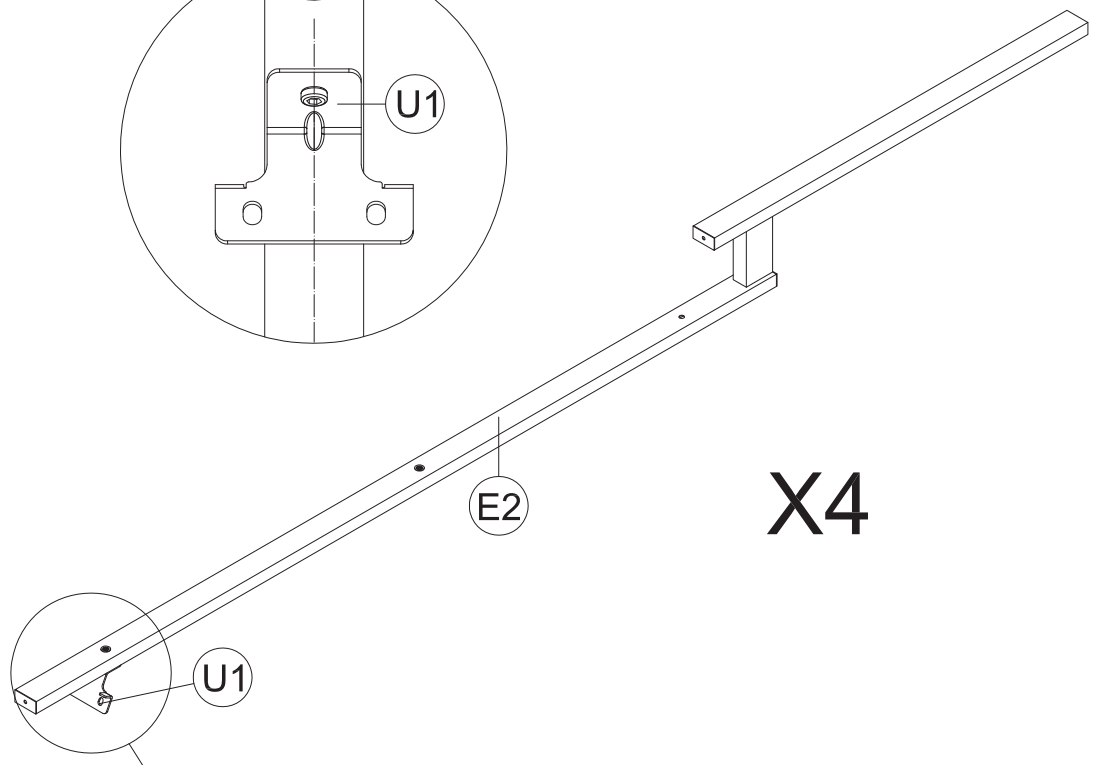
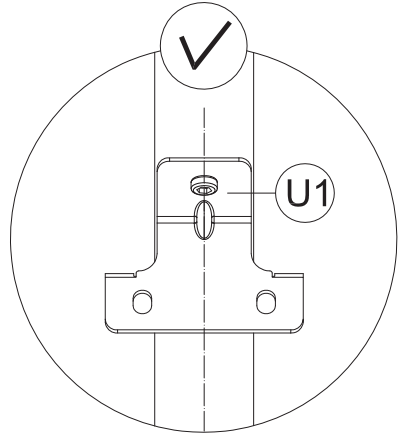
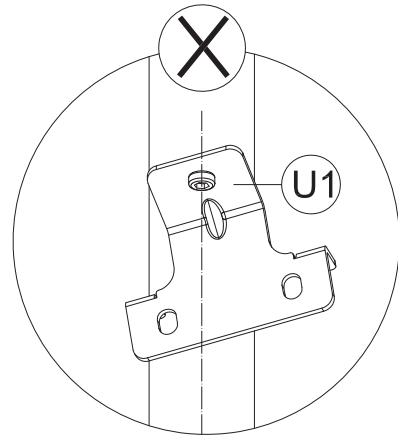
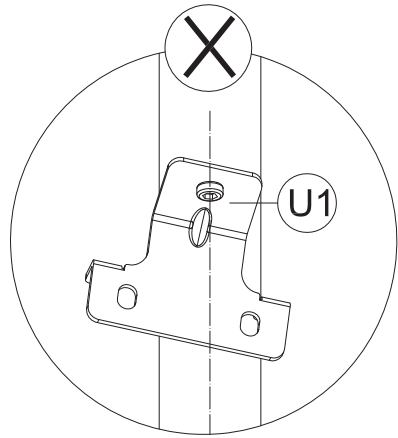
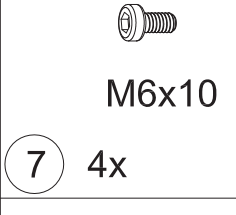
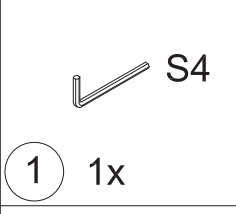
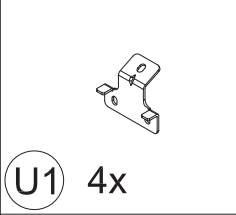
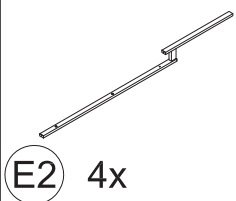

15

- (1) Attach Part #U1 to Part #E2 with Bolt #7 .
- (2) Repeat the above procedures to assemble the other 3 roof bars.

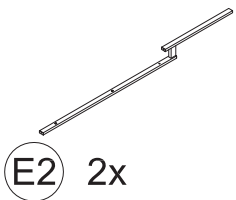

E2 2x



1 1x



M6x16

8 6x

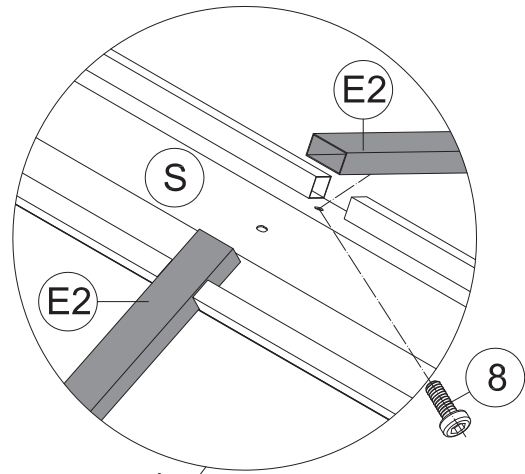

(1) Place Part #E2 on Part #S.  
Secure with Bolt #8 (from bottom to top).

Outside View

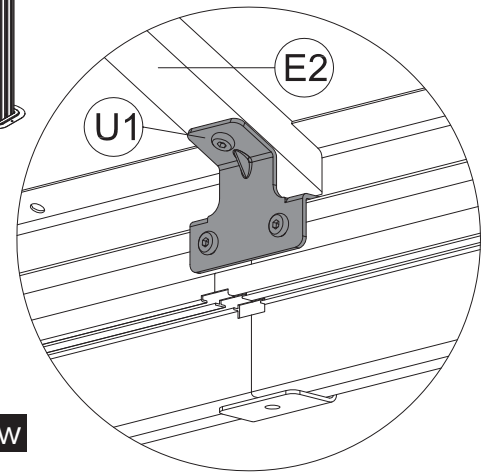
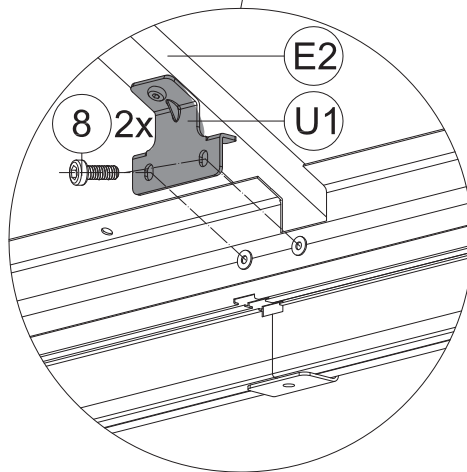
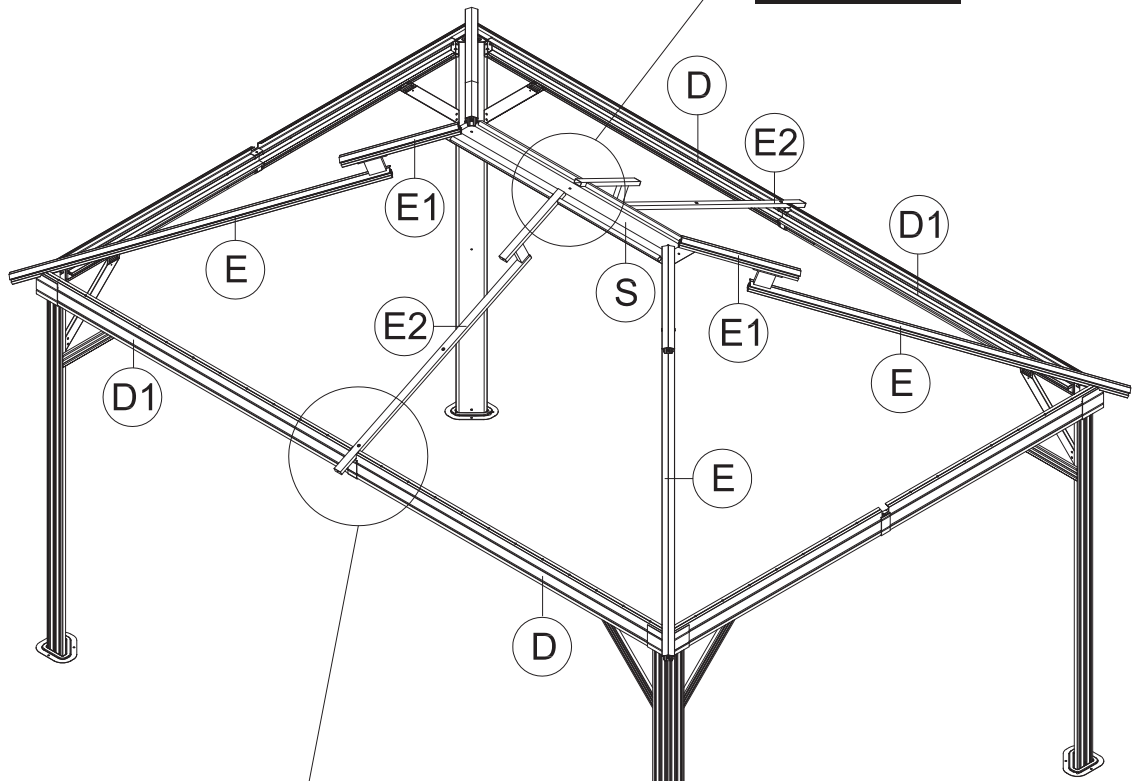

Inside View

(2) Connect Part #E2 and the Assembled Beam(D&D1) with part #U1.  
Secure with 2 Bolts #8.

(3) Repeat the above procedures to assemble the opposite side.

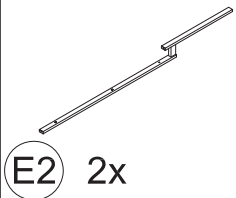

(E2) 2x



(1) 1x



M6x16

(8) 6x

(1) Place Part #E2 on part #S. Secure with Bolt #8 (from bottom to top).

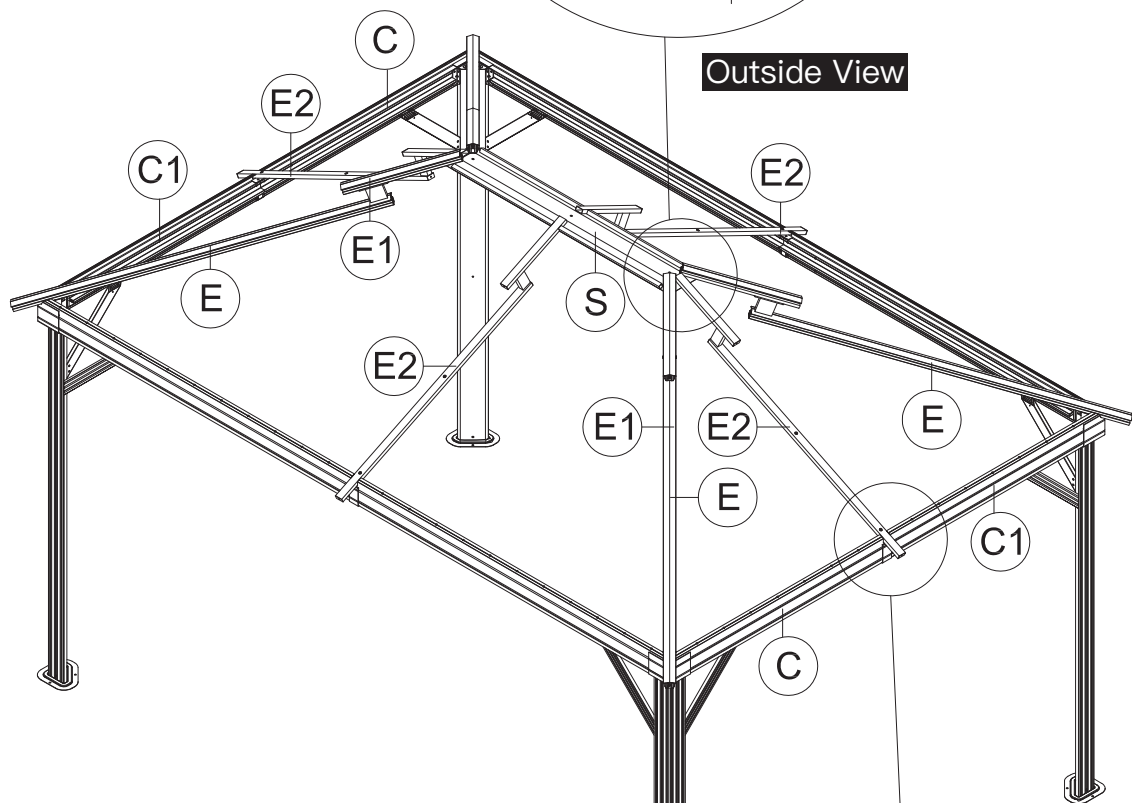
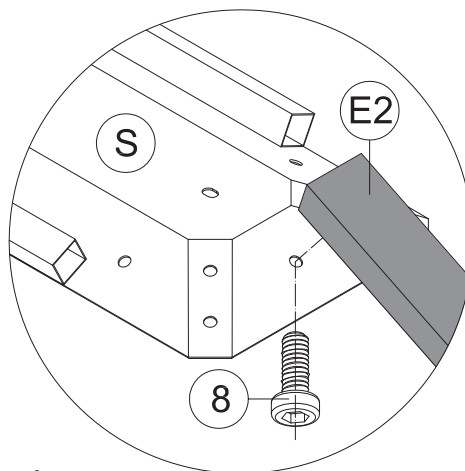

Outside View

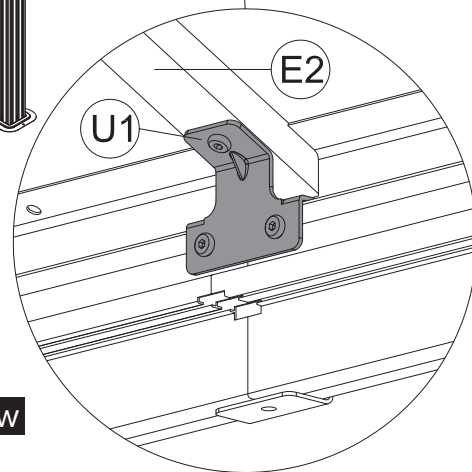
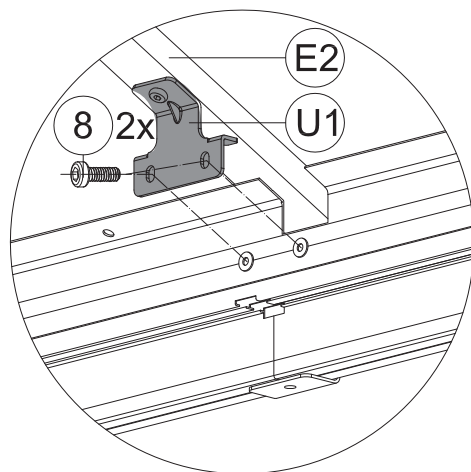

Inside View

(2) Connect Part #E2 and the Assembled Beam(C&C1) with part #U1. Secure with 2 Bolts #8 .

(3) Repeat the above procedures to assemble the opposite side.

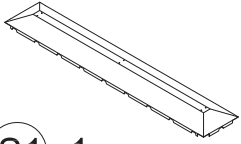

(S1) 1x



(T) 3x

Secure Part #T to Part #S and Part #S1.  
(From Bottom to Top)

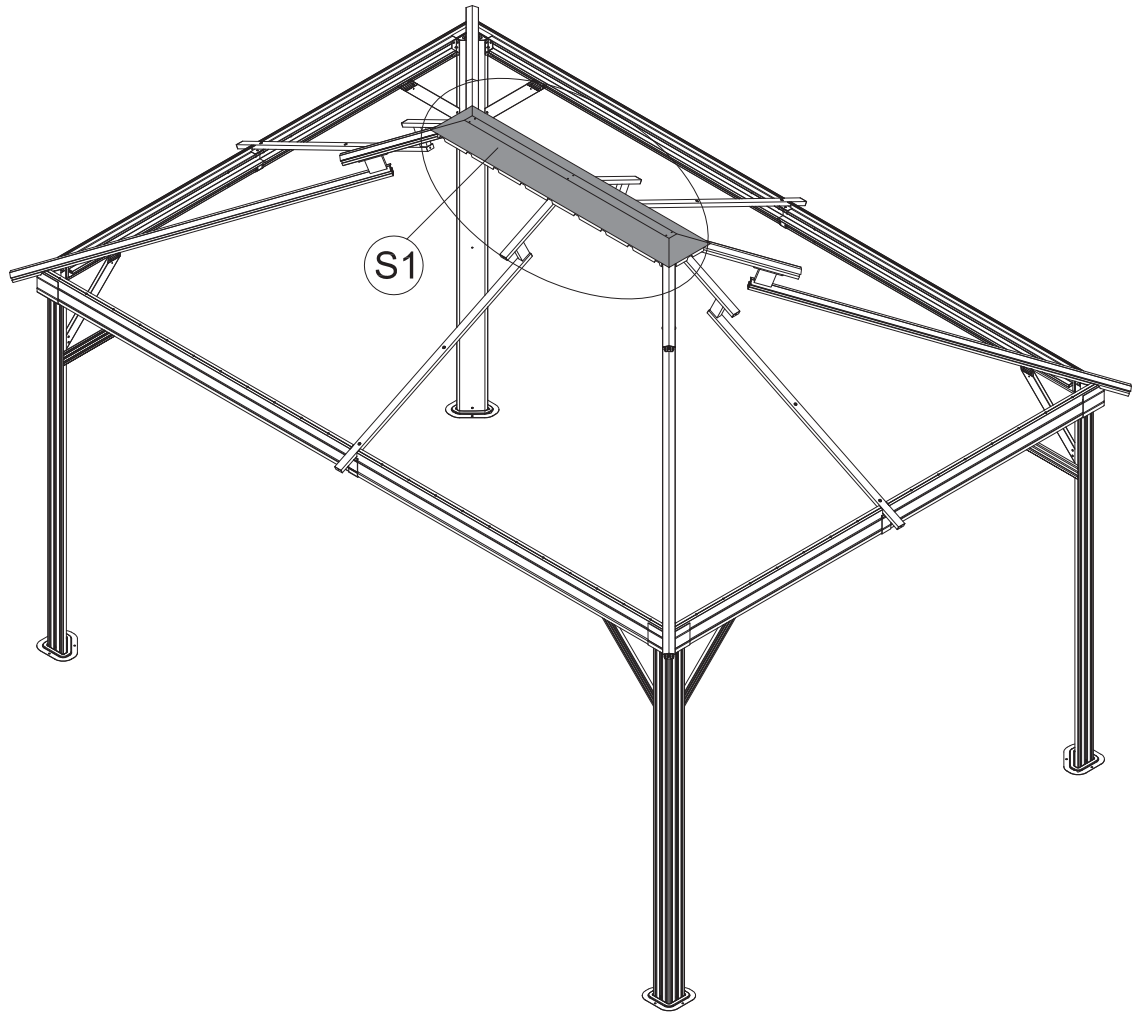
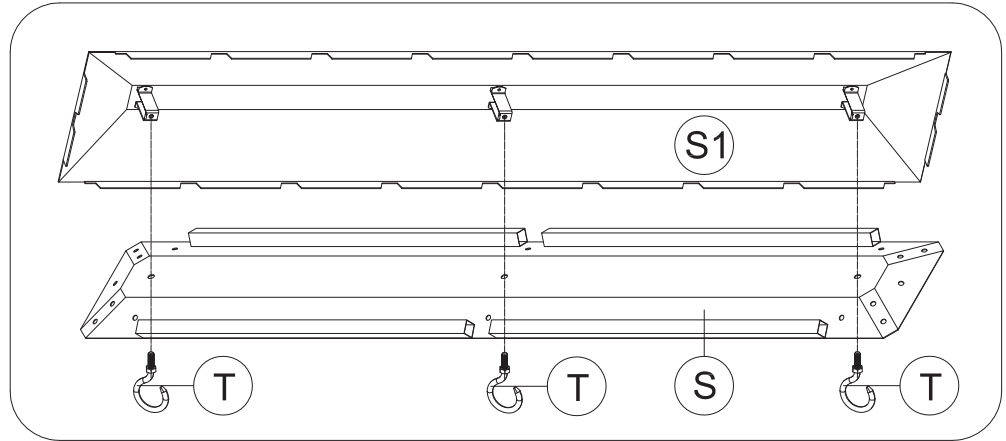

**ATTENTION:** The holes of Part #S and Part #S1 need to be aligned, on the same vertical line.

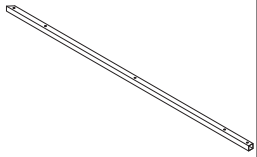

G 2x

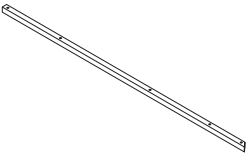

G1 2x

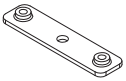

U3 2x



1 1x



M6x10

7 2x



M6x16

8 4x

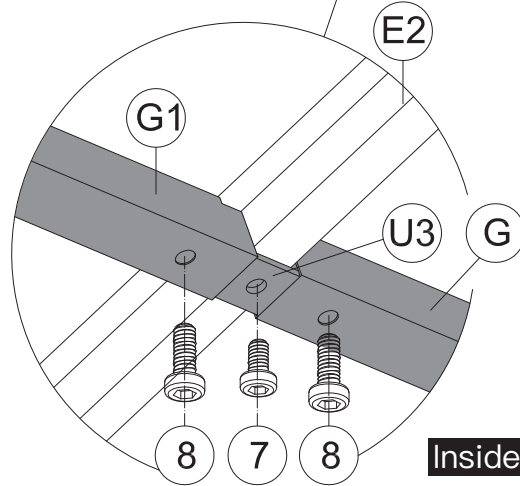
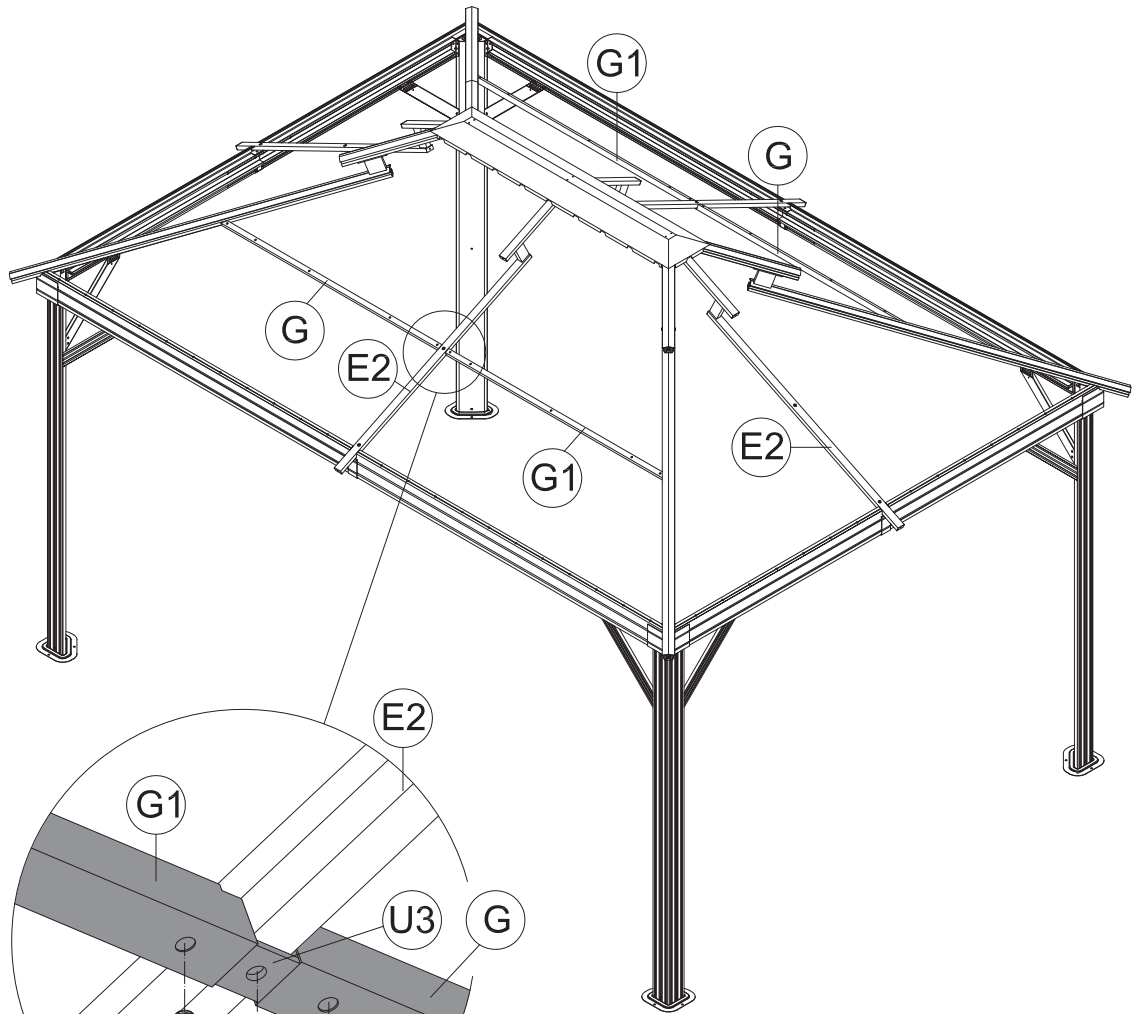

Inside View

(1) Insert Part #U3 into Part #G and Part #G1.

(2) Attach Part #G and Part #G1 to the Part #E2 with 1 Bolt #7 and 2 Bolts #8.

(3) Repeat the above procedures to assemble the opposite side.

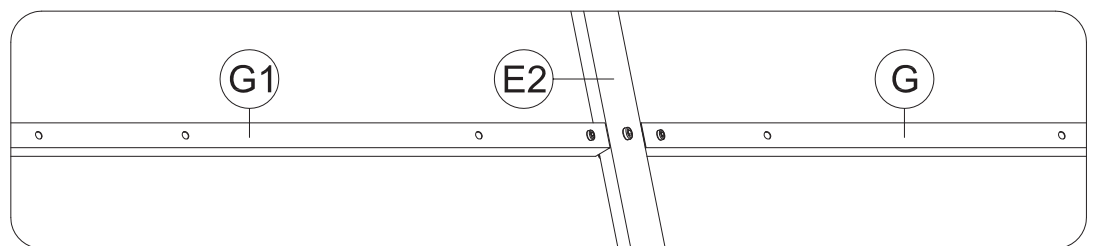

Outside View

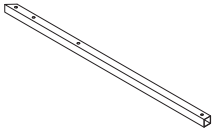

F 4x

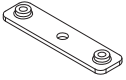

U3 2x



1 1x



M6x10

7 2x



M6x16

8 4x

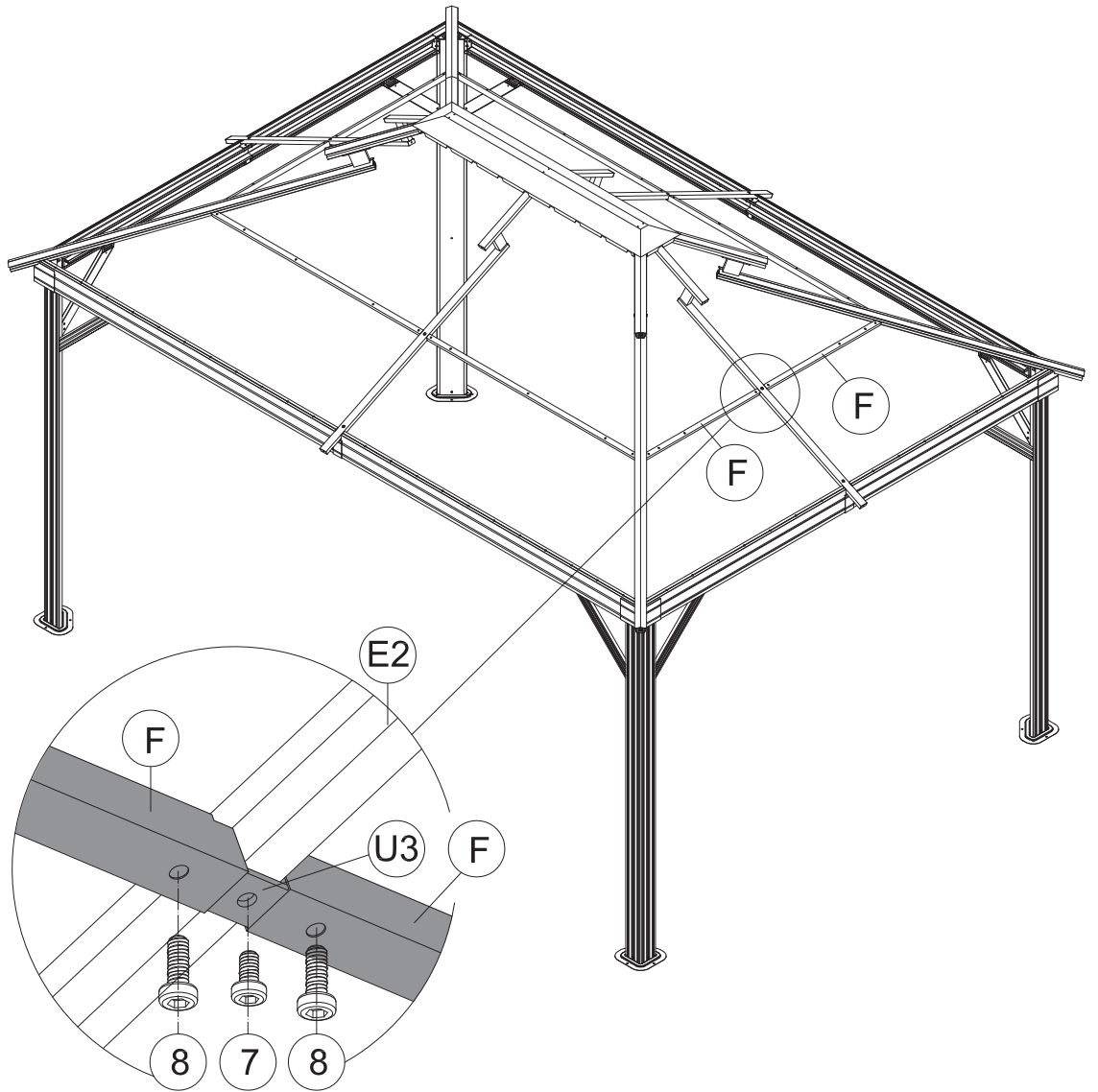

Inside View

- (1) Insert Part #U3 into 2 Part #F.
- (2) Attach 2 Part #F to the Part #E2 with 1 Bolt #7 and 2 Blots #8.
- (3) Repeat the above procedures to assemble the opposite side.

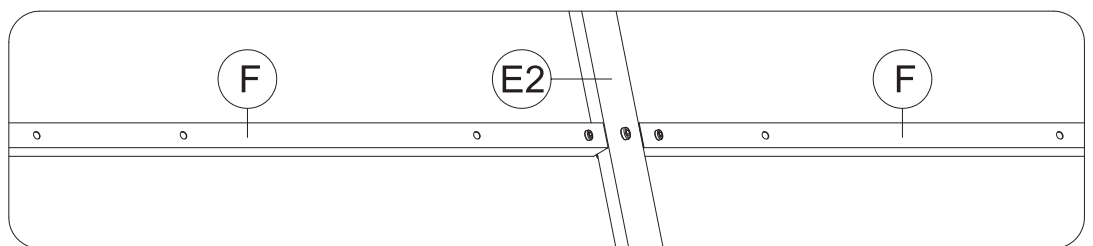

Outside View



U2 4x



1 1x



M6x16

8 12x

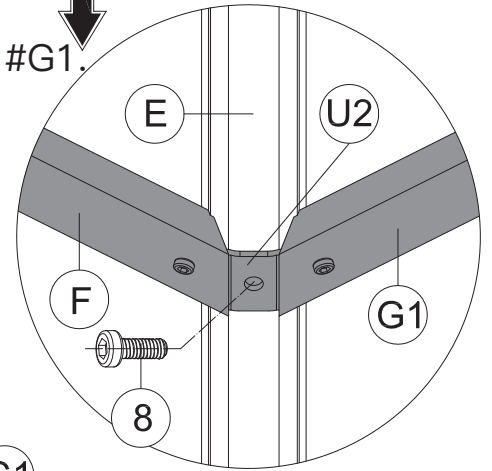
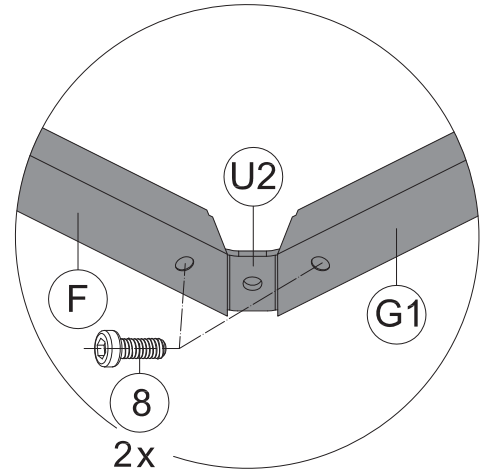
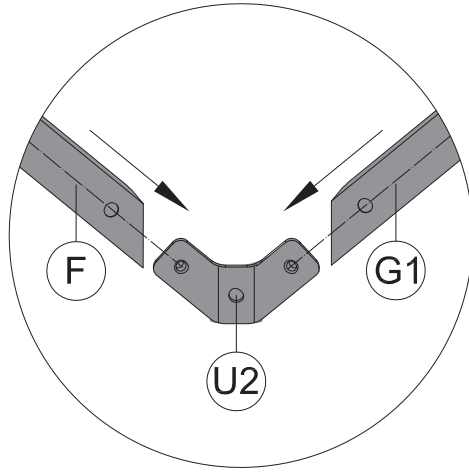

(1) Insert Part #U2 into Part #F and Part #G1.

(2) Secure with 2 Bolts #8.

(3) Secure them to Part #E with Bolt #8.

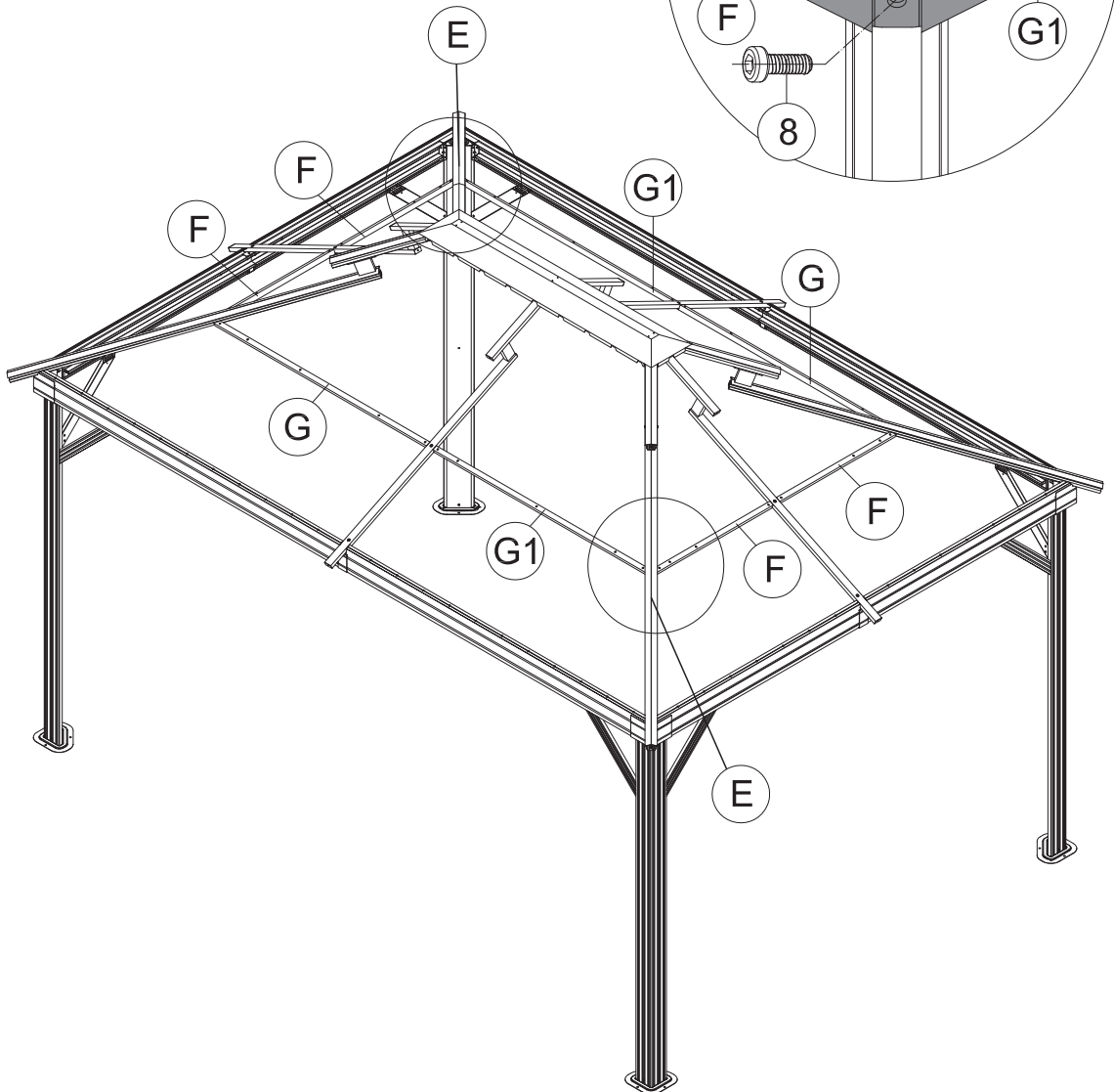

(4) Repeat the above procedures to assemble the other 3 sides.





U2 4x



1 1x



M6x16

8 12x

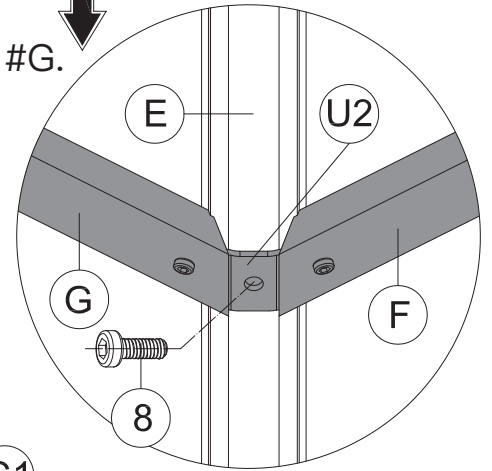
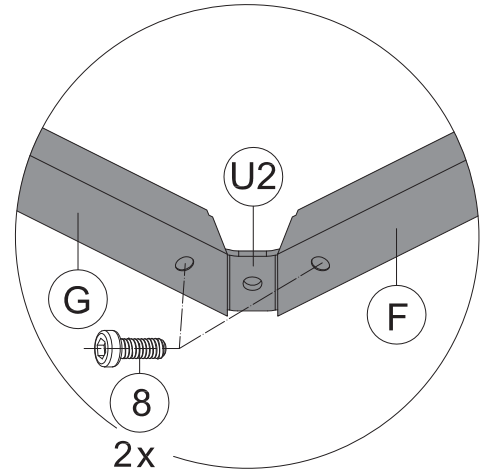
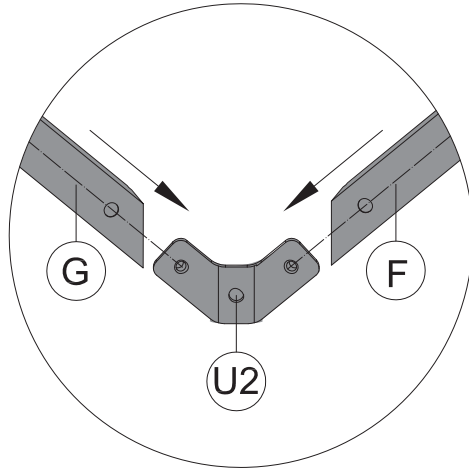

(1) Insert Part #U2 into Part #F and Part #G.

(2) Secure with 2 Bolts #8.

(3) Secure them to Part #E with Bolt #8.

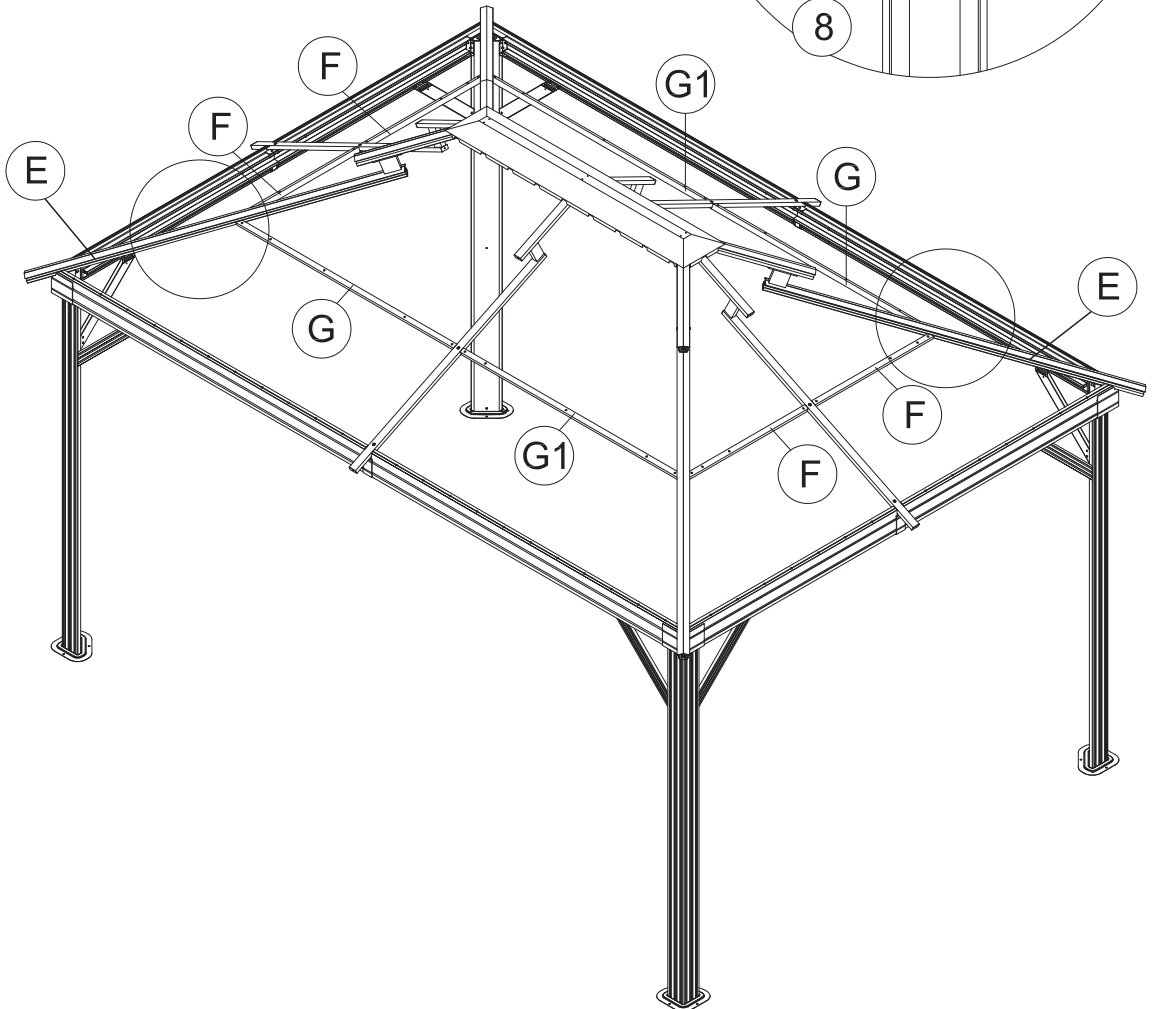

(4) Repeat the above procedures to assemble the other 3 sides.

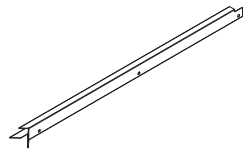

J1 2x

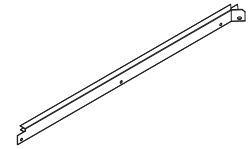

J2 2x

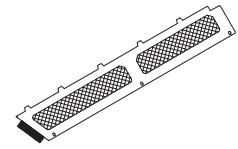

Q1 2x

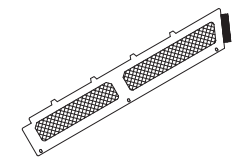

Q2 2x

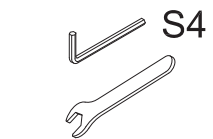

1 1x



5 8x



7 8x

23

(1) Connect Part #J1 and Part #Q1 with 2 Bolts #7 and 2 Nuts #5.

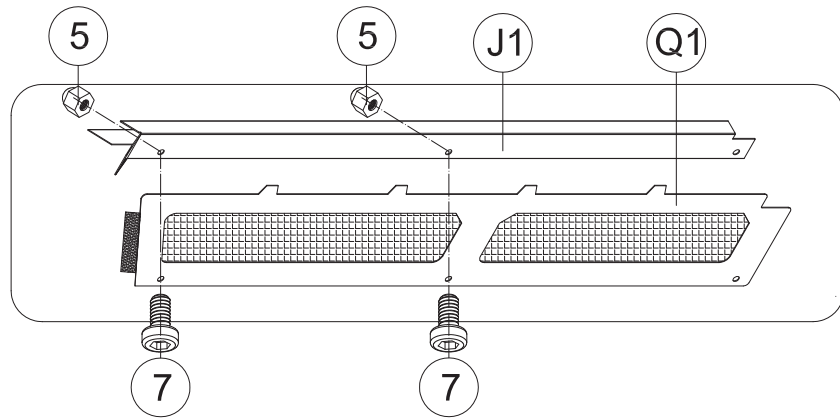

X2

(2) Connect Part #J2 and Part #Q2 with 2 Bolts #7 and 2 Nuts #5.

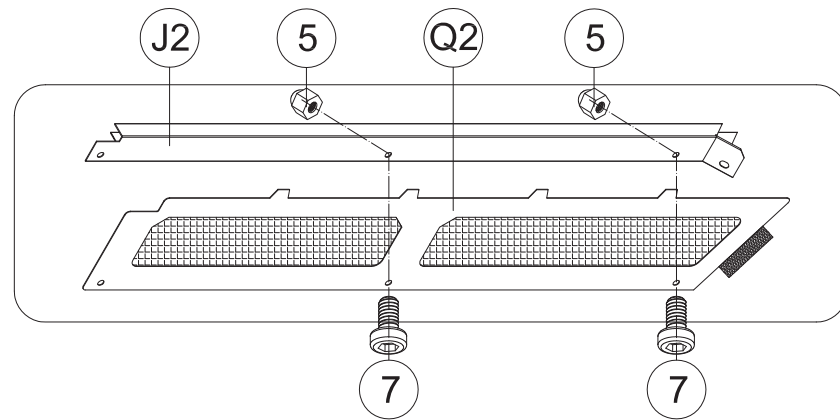

X2

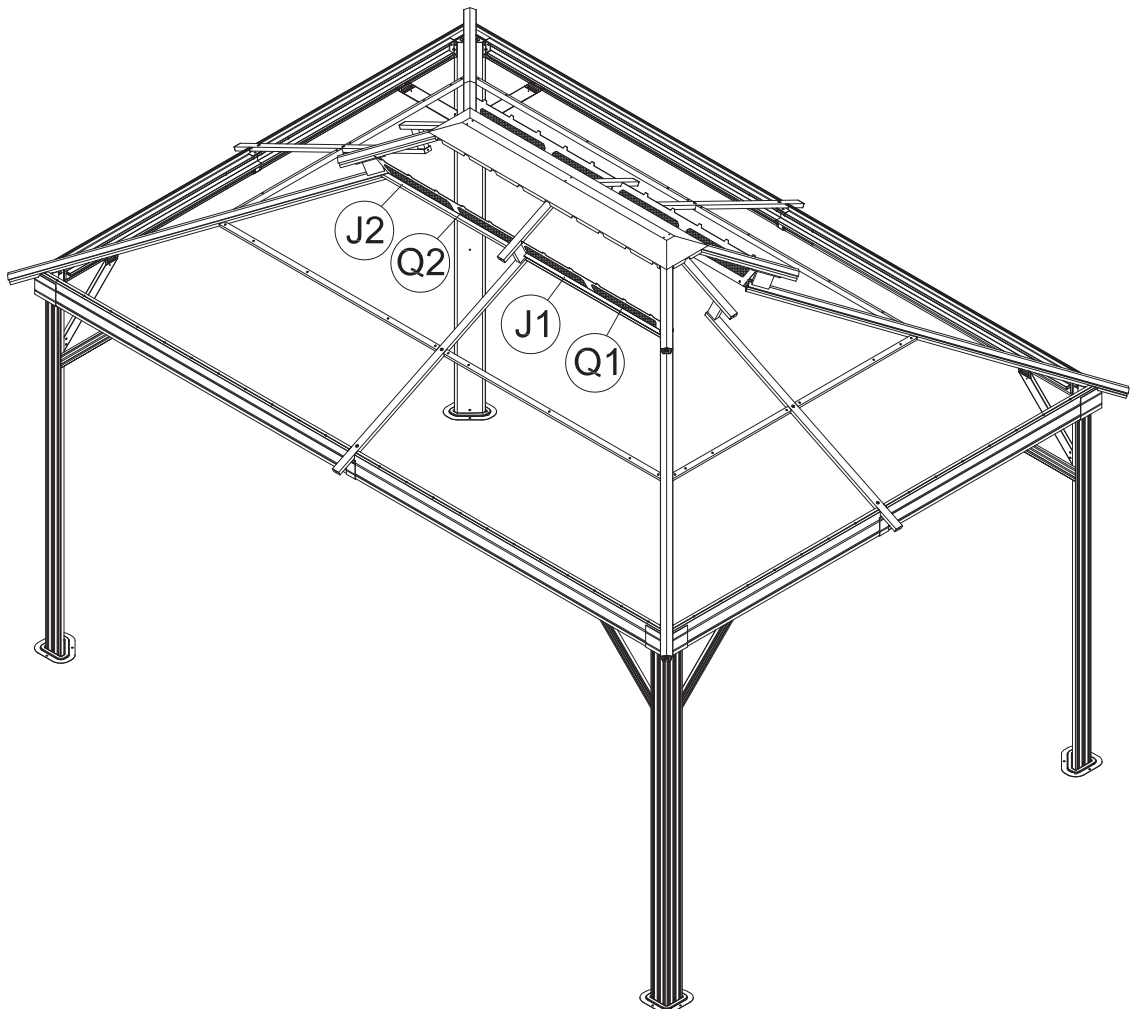

S4

1 1x



M6x16

8 2x

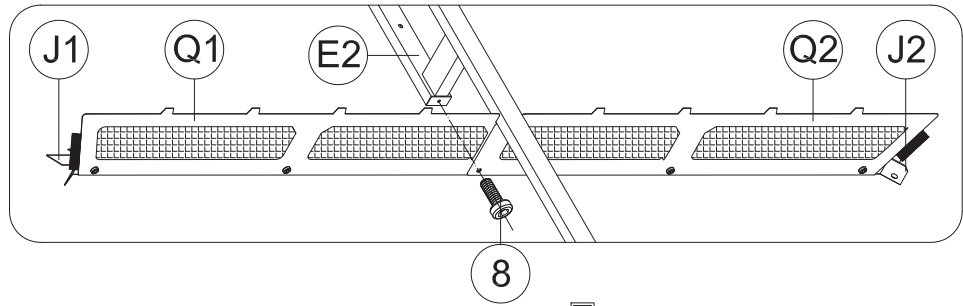

Inside View

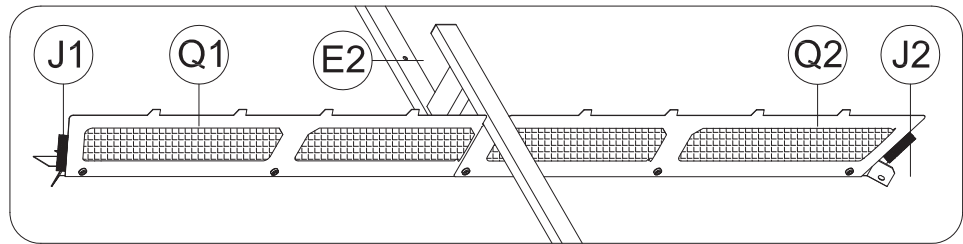

(1) Place the Assembled J1 & Q1 and J2 & Q2 on Part #E2, securing with 1 Bolt #8.

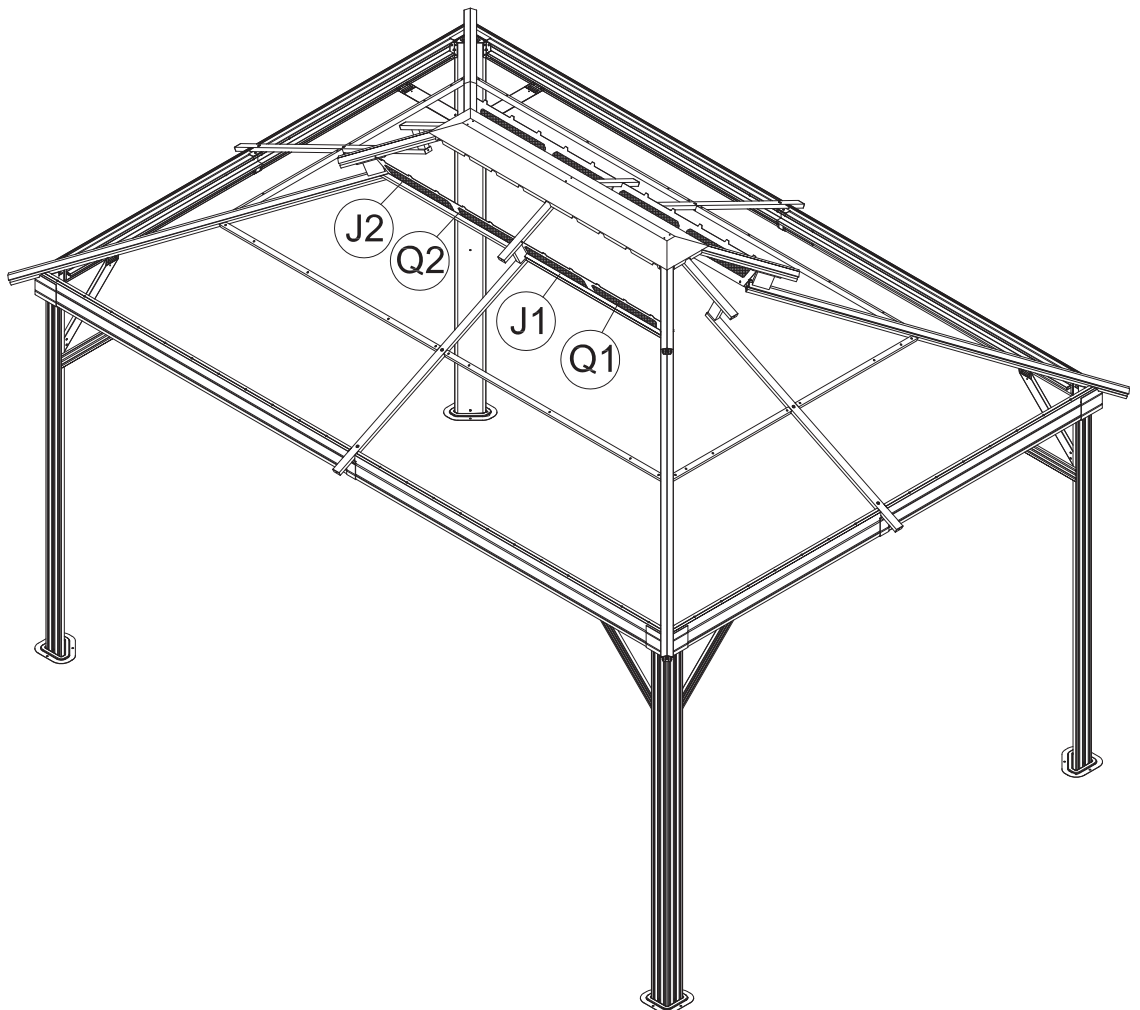

(2) Repeat the above procedures to assemble the opposite side.

(1) Connect Part #J and Part #Q with 2 Bolts #7 and 2 Nuts #5.

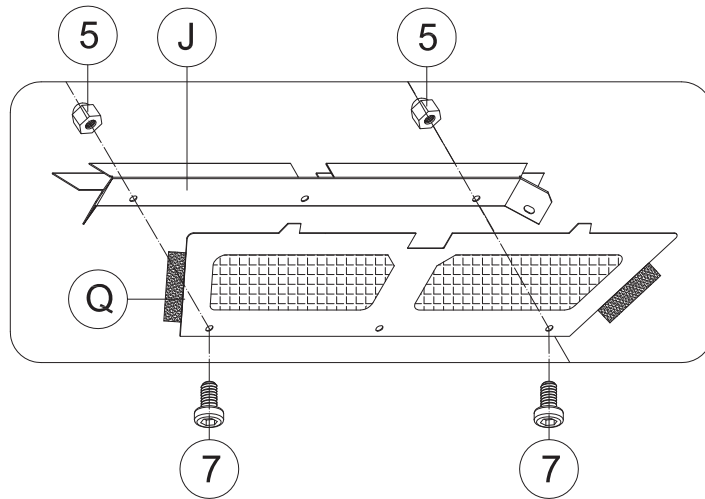

(2) Place the Assembled Part #J & #Q on Part #E2, securing with 1 Bolt #8.

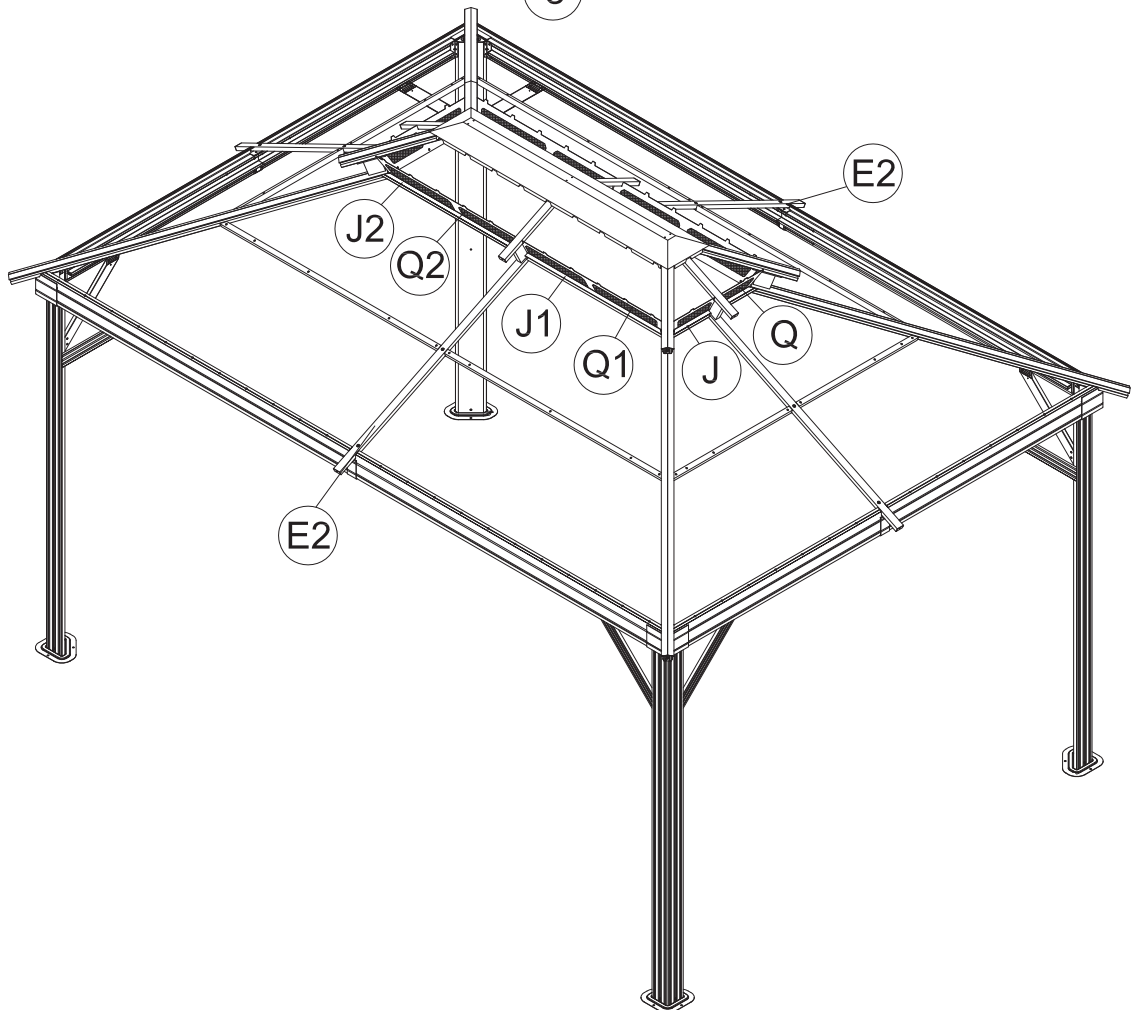
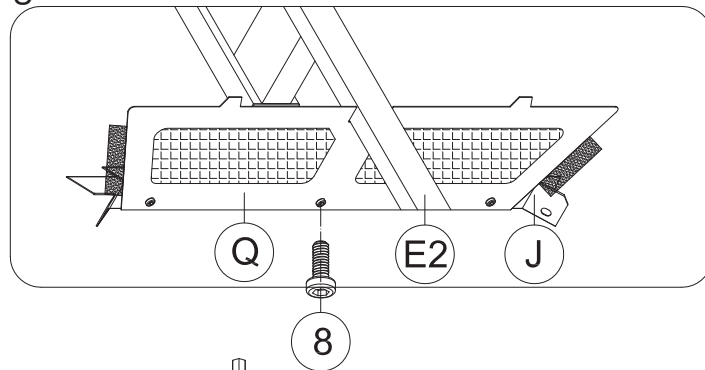

(3) Repeat the above procedures to assemble the opposite side.

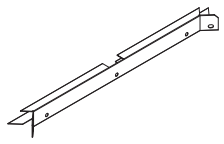

J 2x

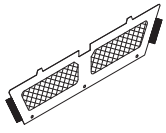

Q 2x



1 1x



M6

5 4x



M6x10

7 4x



M6x16

8 2x



X3 4x



1 1x



ST6.3x15

2 4x

(1) Place Part #J and Part #J1 on Part #E;  
put on Part #X3 and secure with Self-tapping Screw #2.

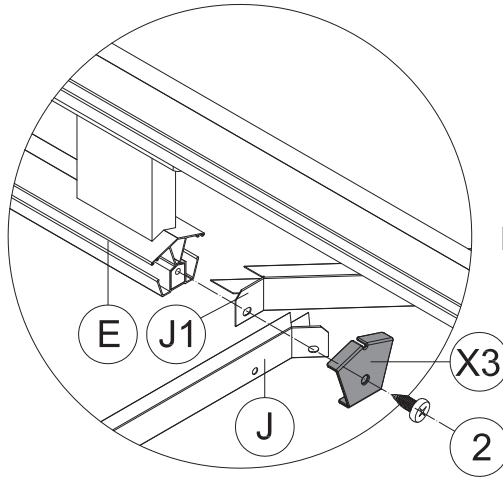

Inside View

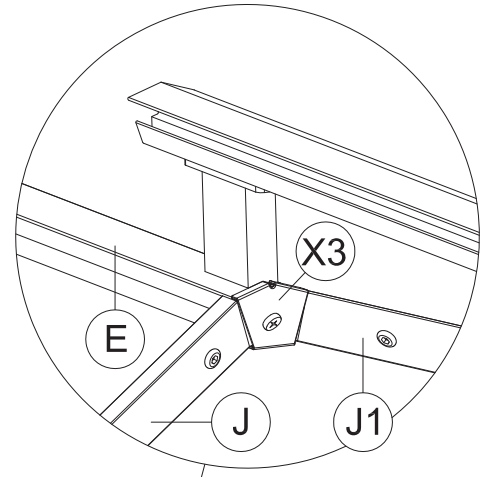

Inside View

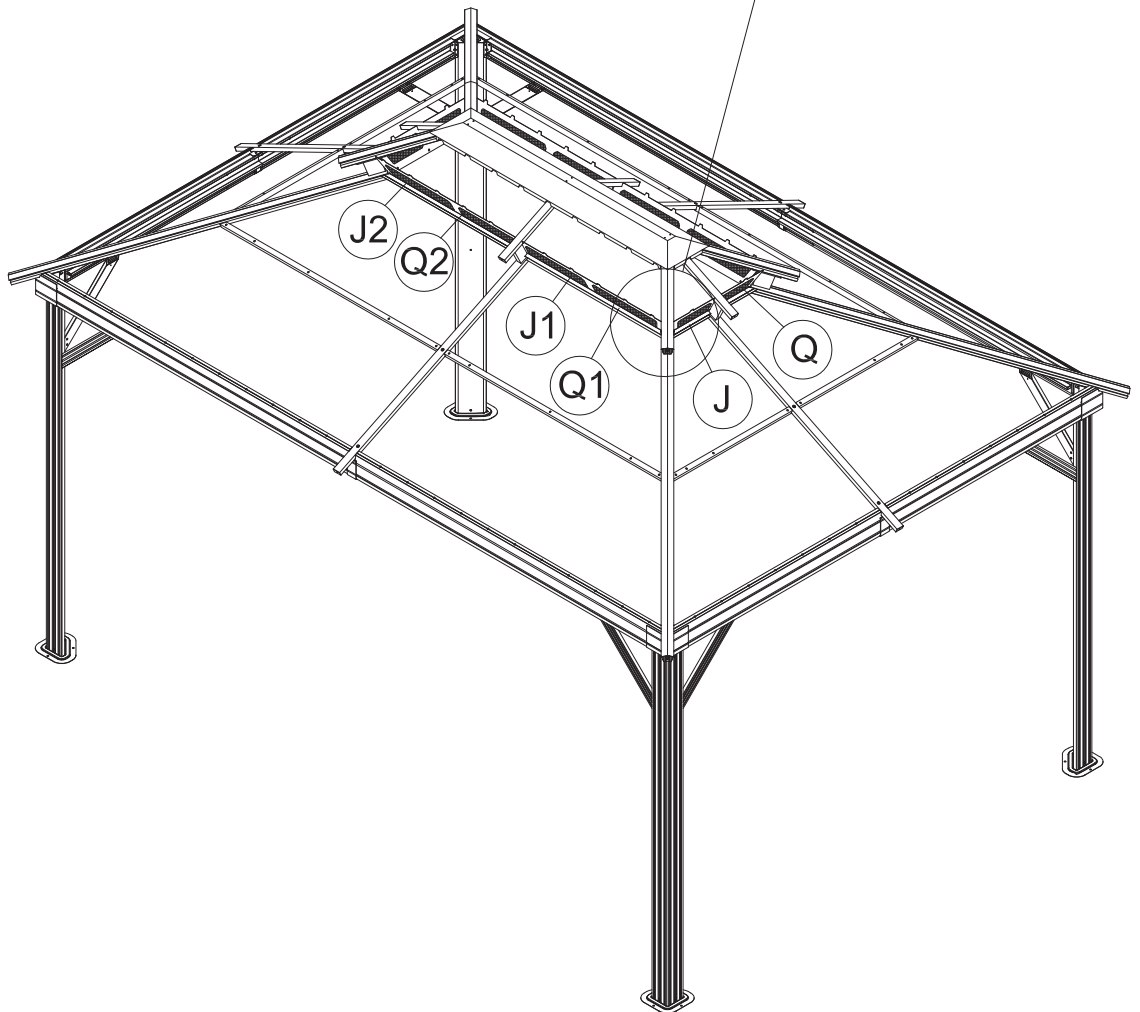

(2) Repeat the above procedures to assemble the other 3 corners.

# Cover Part #Z, #Z1 & #Z2 to Roof Panels.

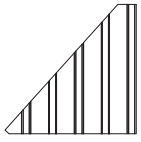

L1 2x

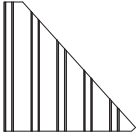

L2 2x



Z 4x



Z1 2x



Z2 2x

X2

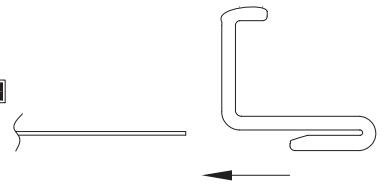
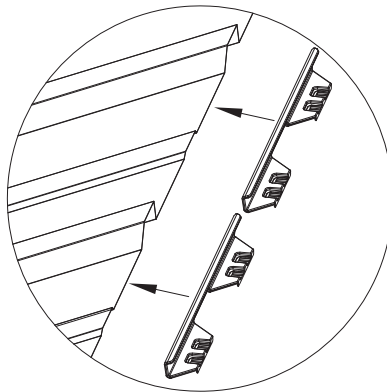
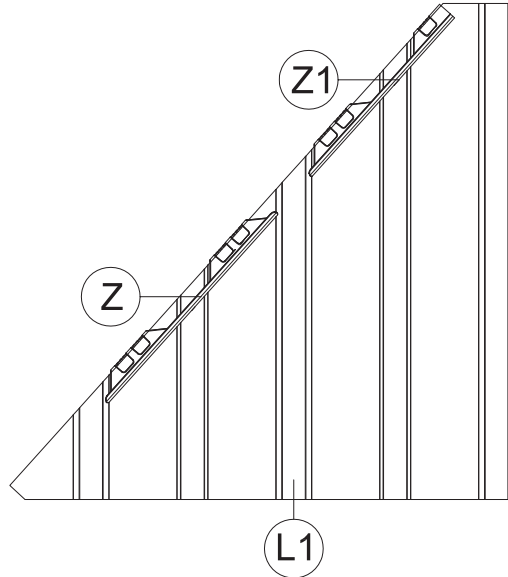

Section View

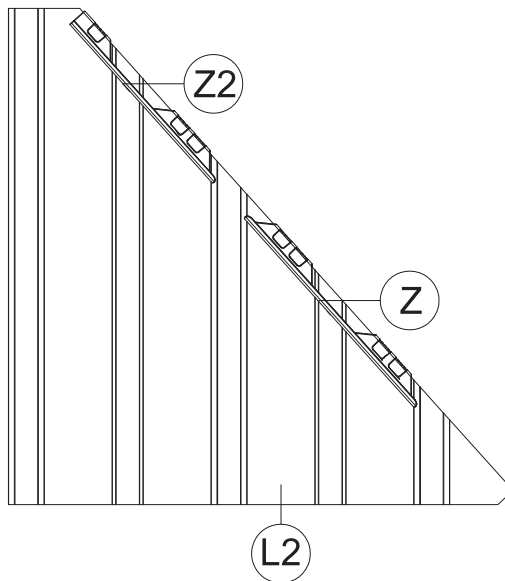

X2

# Cover Part #Z to Roof Panels.

(N1) 2x

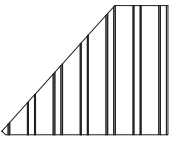

(N2) 4x

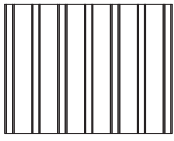

(N3) 2x

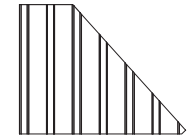

(Z) 8x

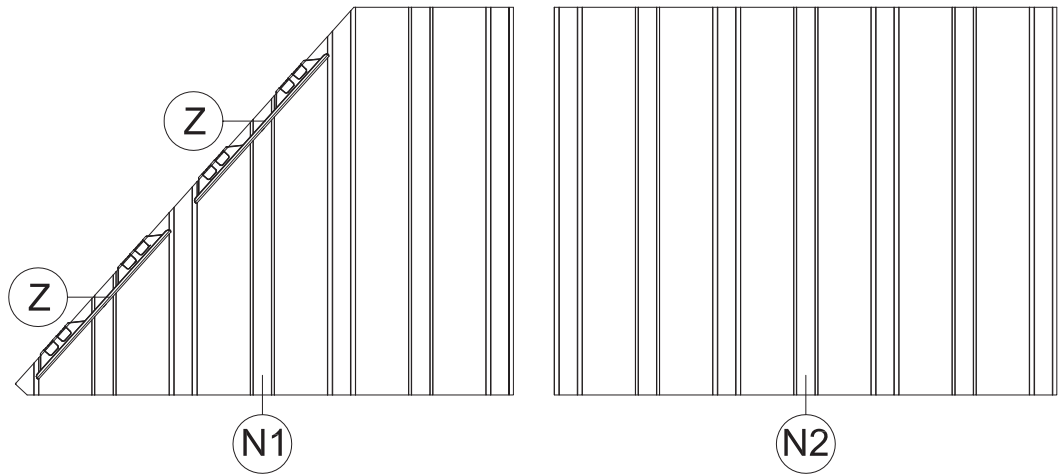

X2

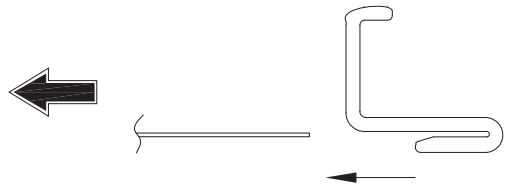
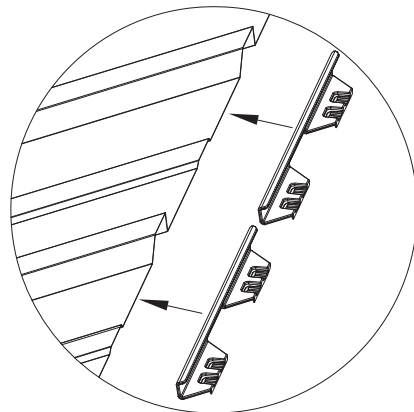

Section View

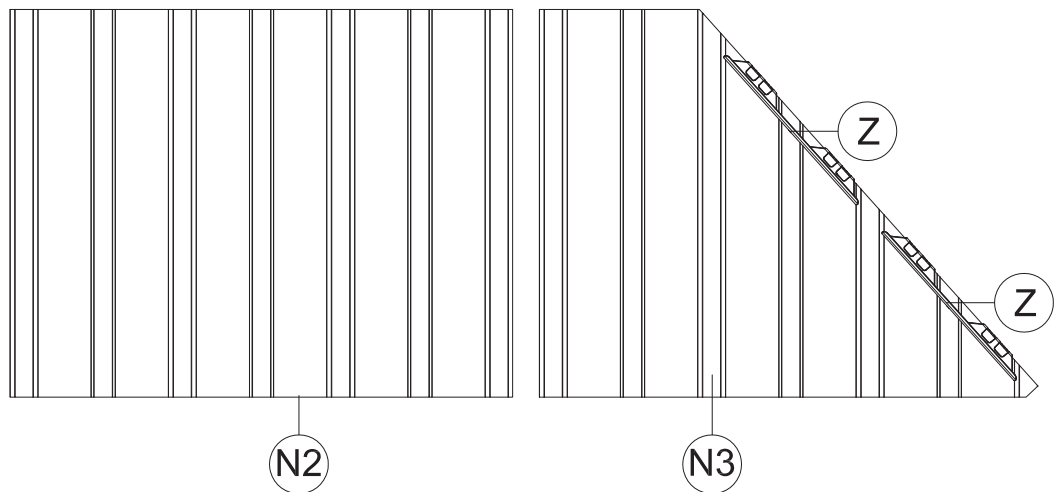

X2

**ATTENTION: The bigger roof panel need to cover the smaller one.**

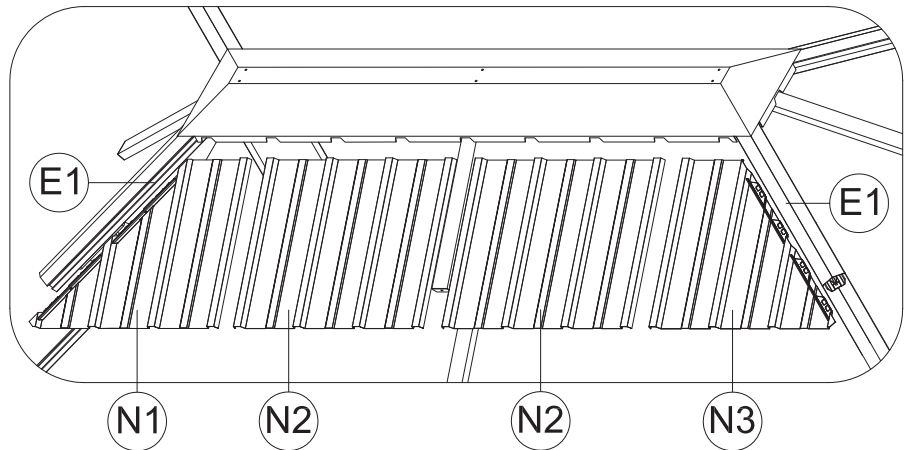

(1) Insert Part #N1 and Part #N2 into the frame.

(2) Insert Part #N3 and Part #N2 into the frame.

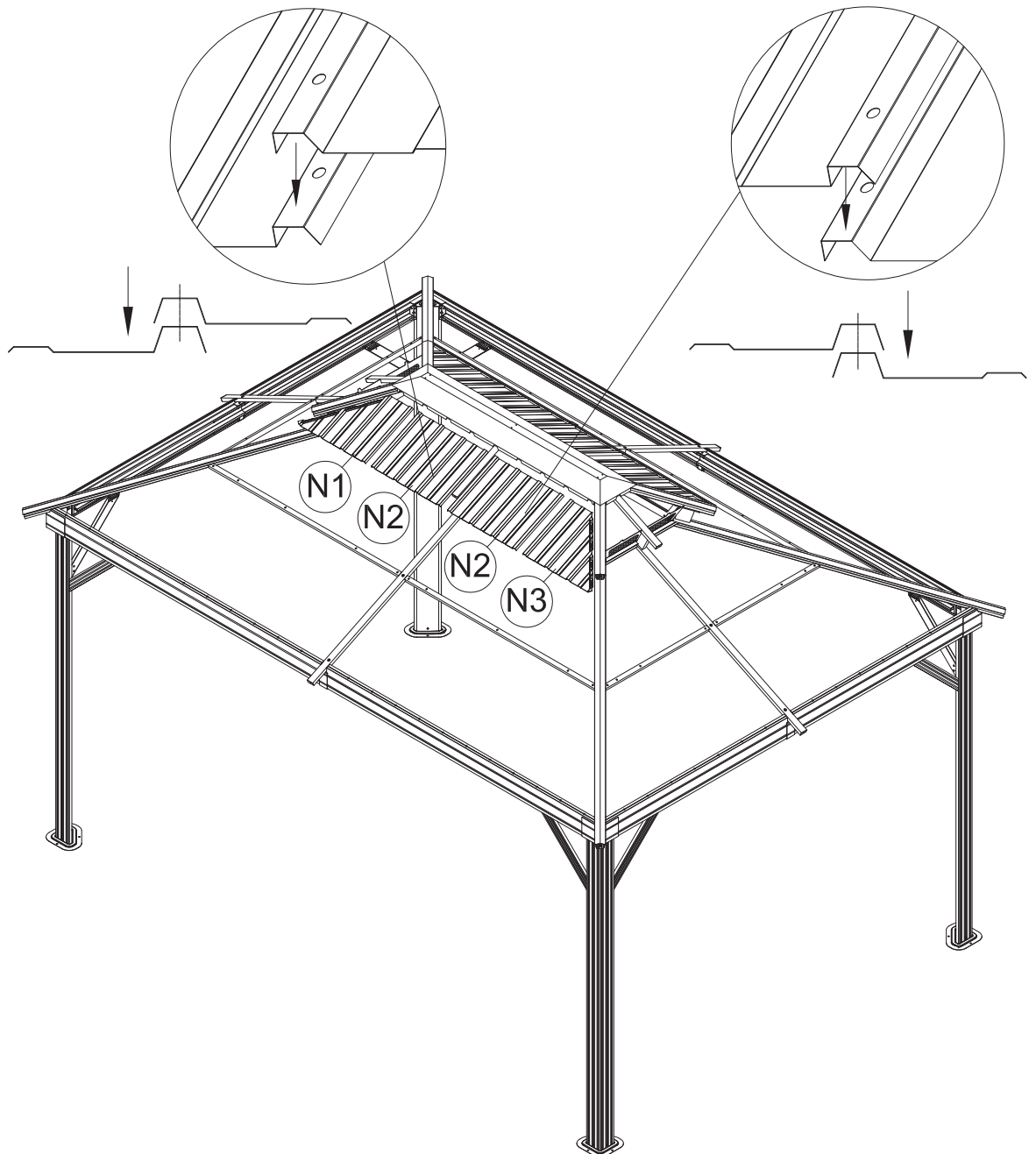

(3) Repeat the above procedures to assemble the opposite side.



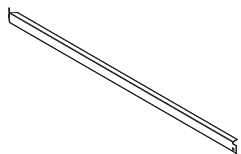

H1 2x

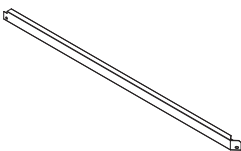

H2 2x



X2 2x



1 1x



M6x16

8 2x

(1) Place Part #H1 and Part #H2 on Part #E2;  
put on Part #X2 and secure with Bolt #8.

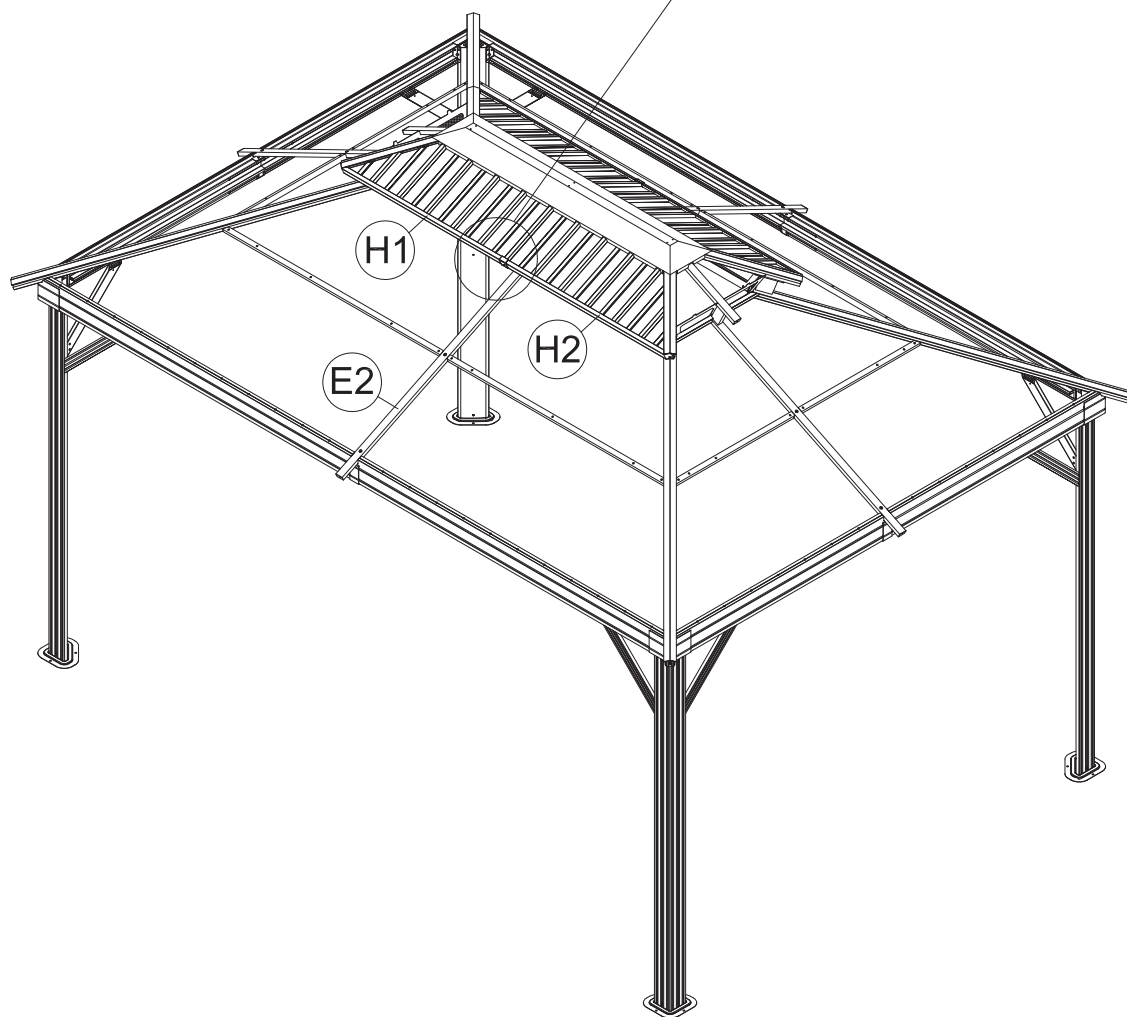
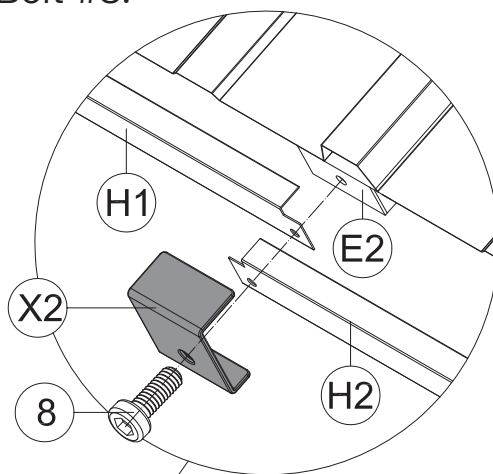

(2) Repeat the above procedures to assemble the opposite side.

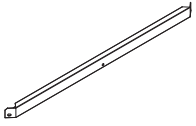

- (1) Insert Part #L1 into the frame.
- (2) Insert Part #L2 into the frame.

(H) 2x



(1) 1x



M6x16

(8) 2x

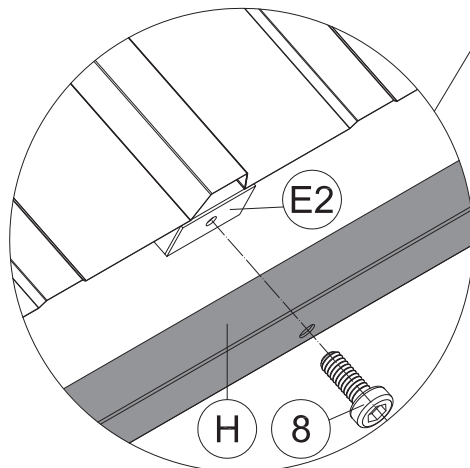
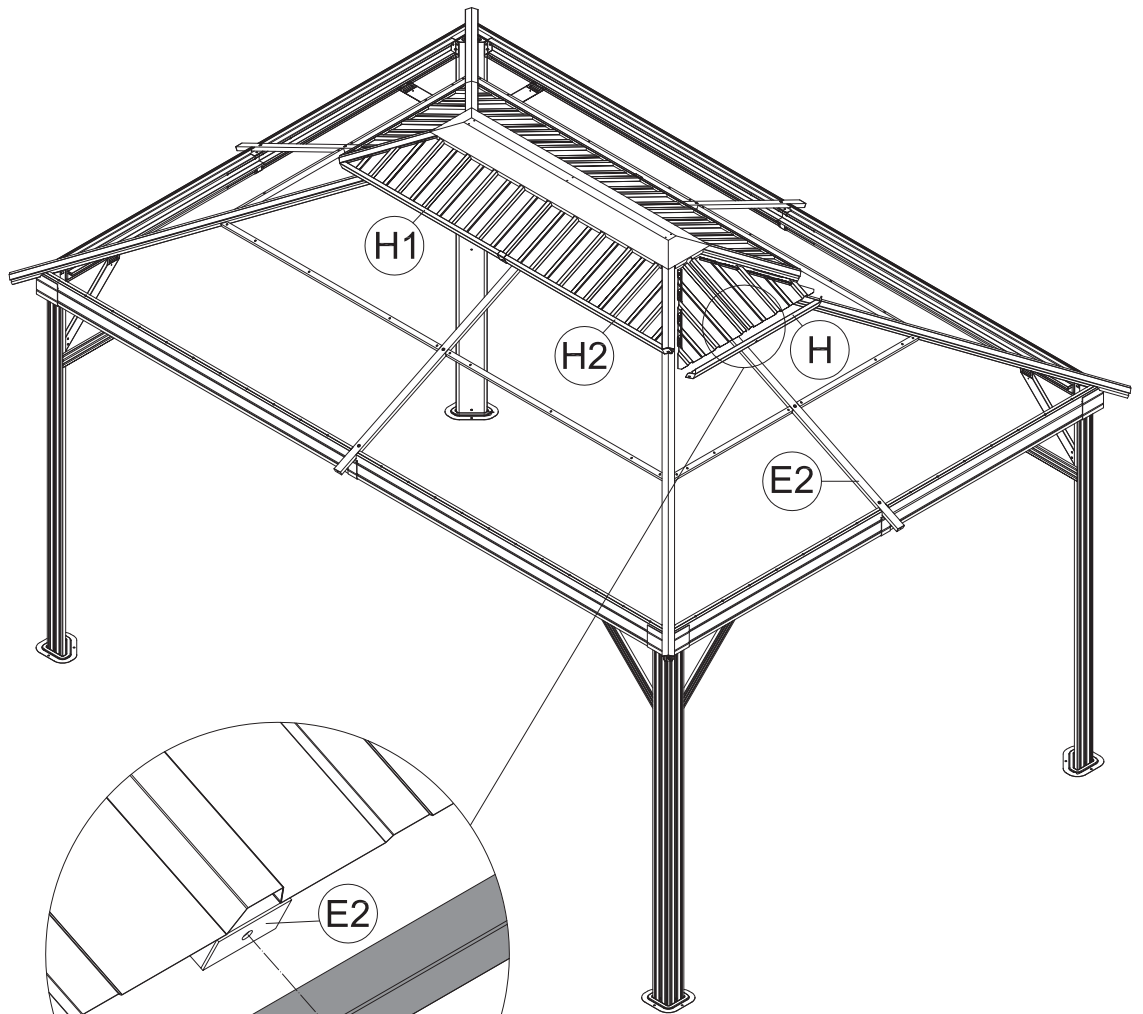
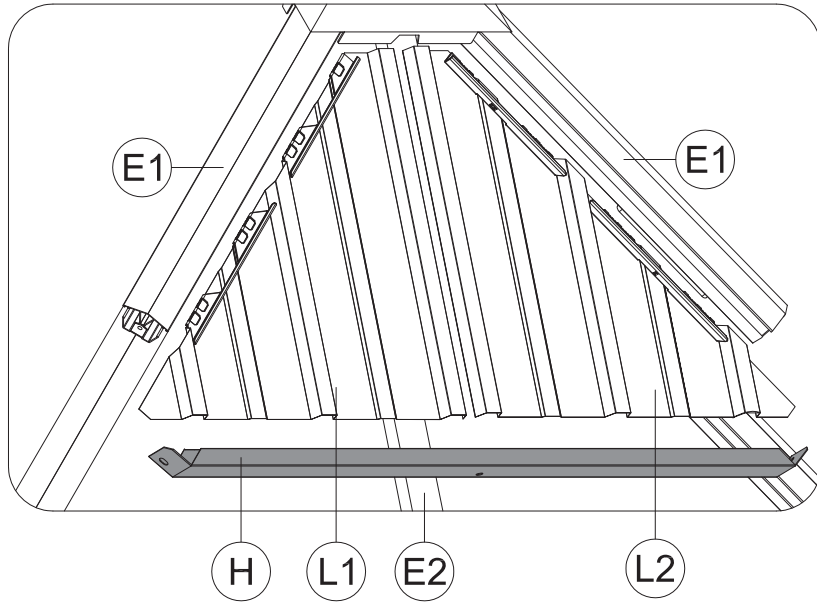

- (3) Attach Part #H to Part #E2, securing with Bolt #8.

- (4) Repeat the above procedures to assemble the opposite side.



X3 4x



1 1x



ST6.3x15

2 4x

(1) Place Part #H and Part #H2 on Part #E1;  
put on Part #X3 and secure with Self-tapping Screw #2

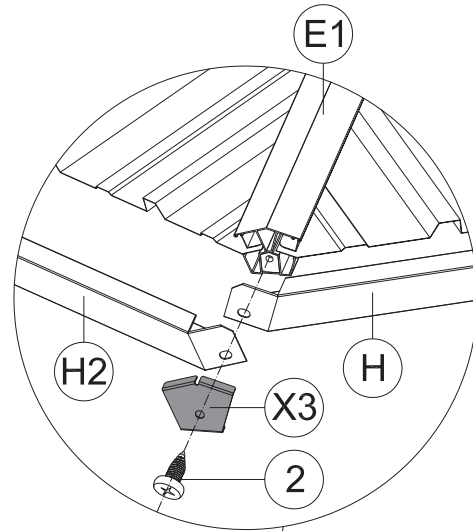



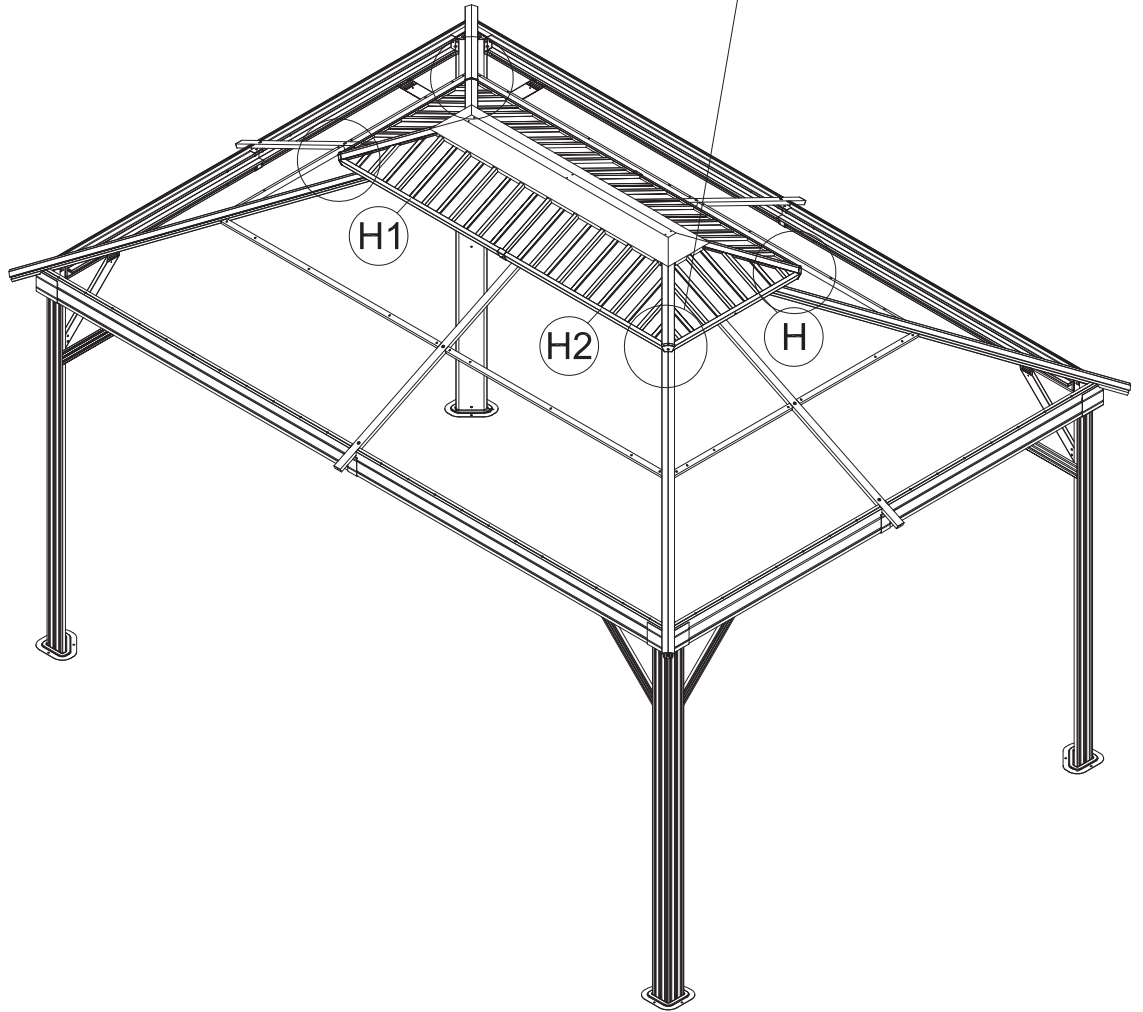



Outside View

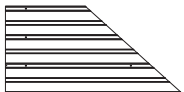
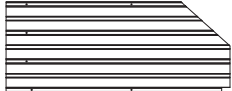
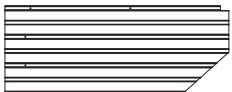



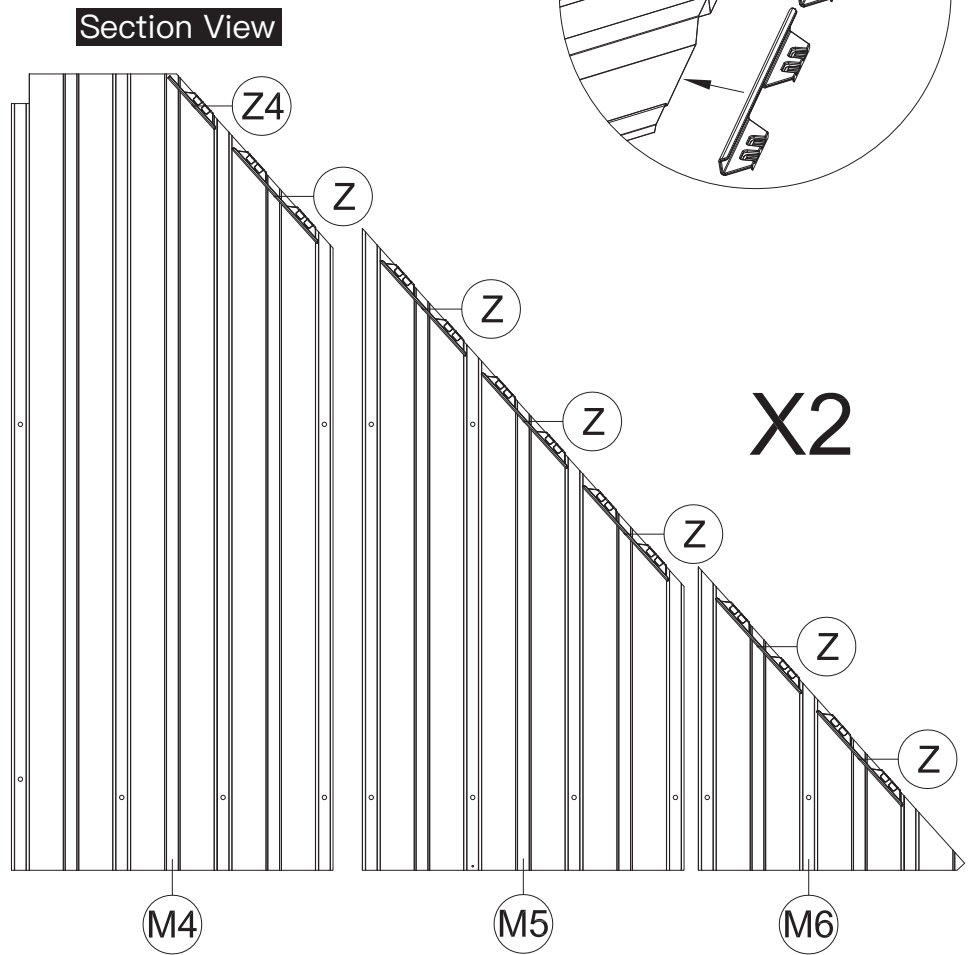
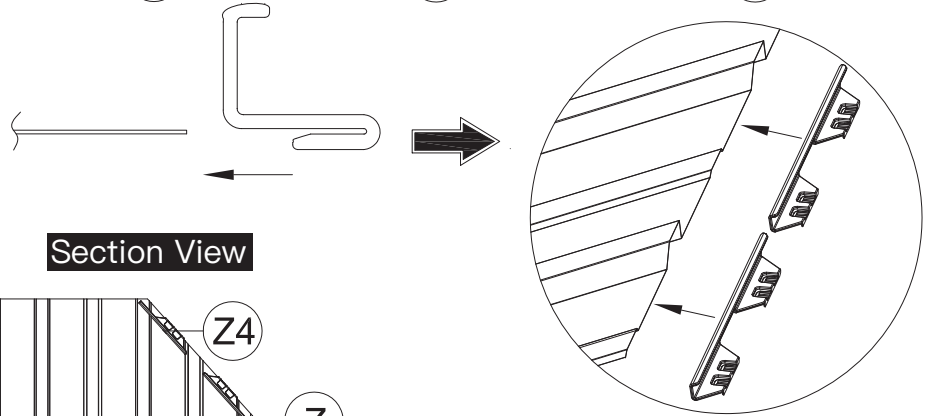
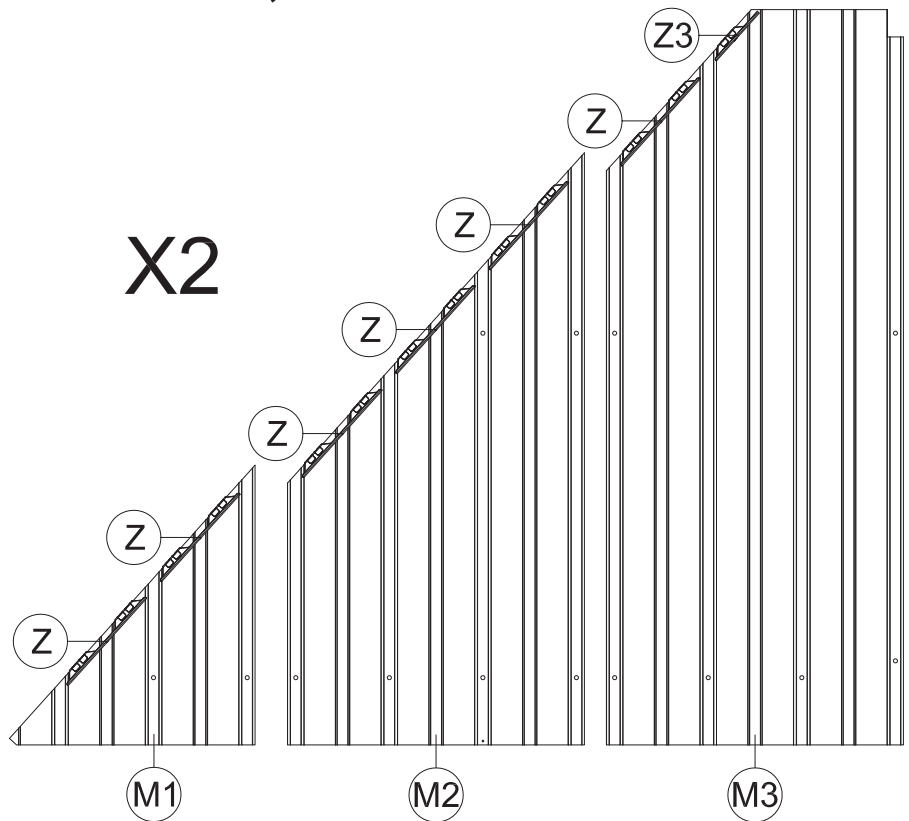

(2) Repeat the above procedures to assemble the other 3 corners.

# Cover Part #Z# , Z3 & #Z4 to Roof Panels

-  (M1) 2x
-  (M2) 2x
-  (M3) 2x
-  (M4) 2x
-  (M5) 2x
-  (M6) 2x
-  (Z) 24x
-  (Z3) 2x
-  (Z4) 2x

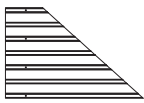
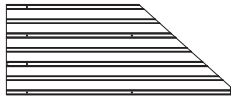

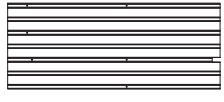
# Cover Part #Z & #Z1 to Roof Panels

-  **P1** 2x
-  **P2** 2x
-  **P3** 2x
-  **P4** 4x
-  **P5** 2x
-  **Z** 12x
-  **Z1** 2x

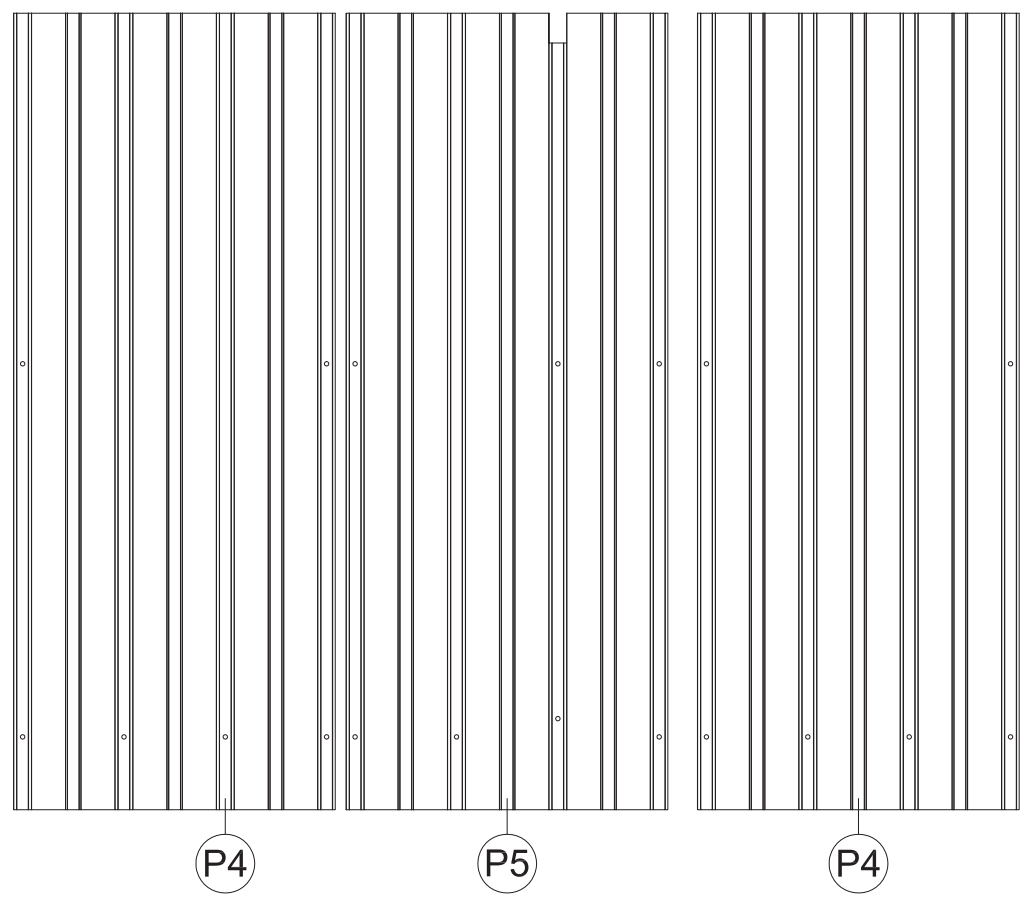
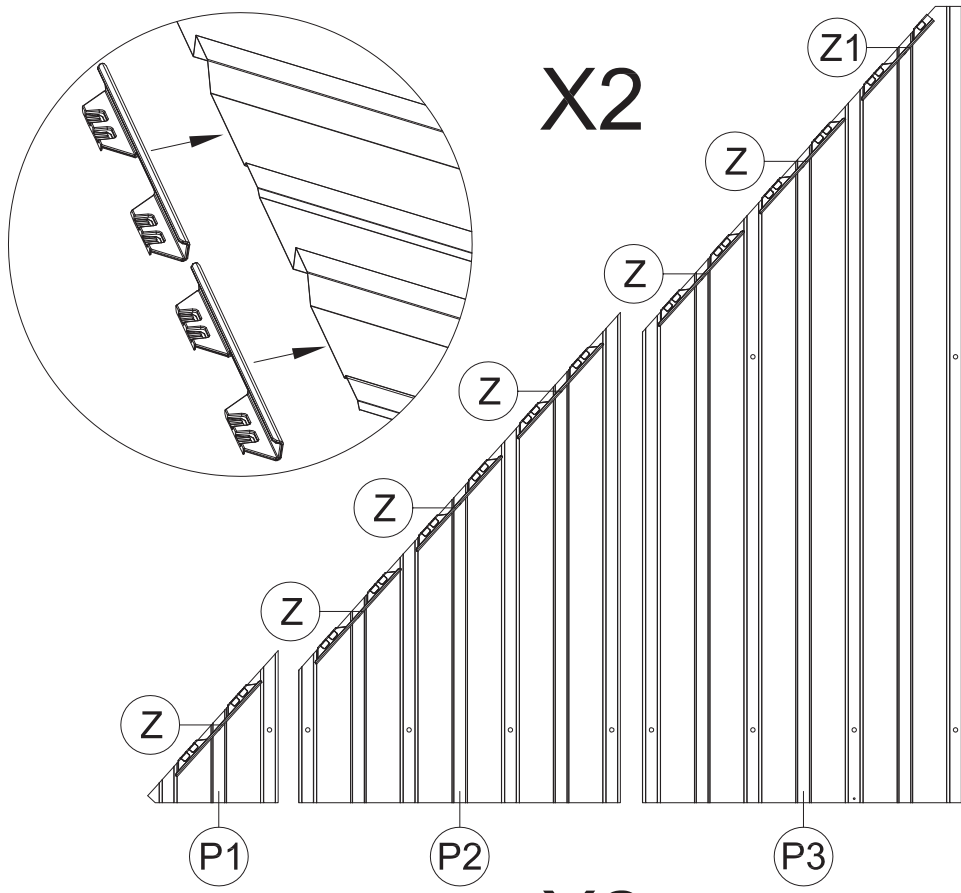

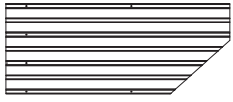

P6 2x

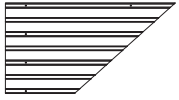

P7 2x



P8 2x



Z 12x



Z2 2x

# Cover Part #Z & #Z2 to Roof Panels

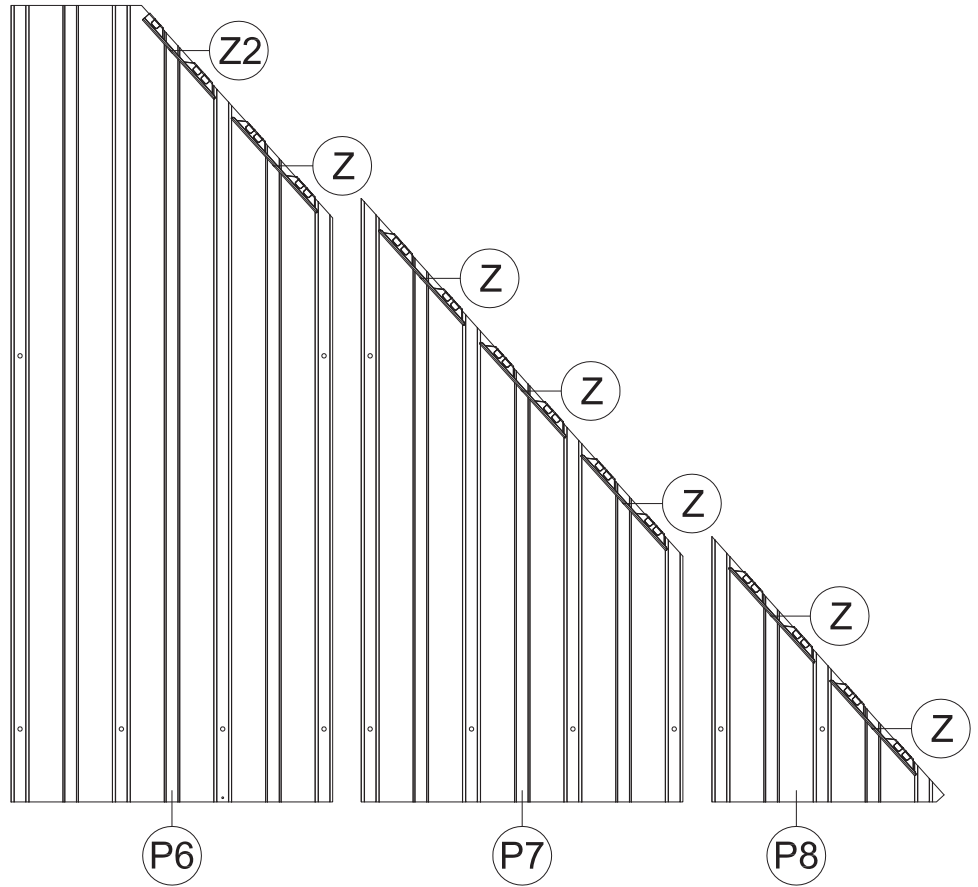
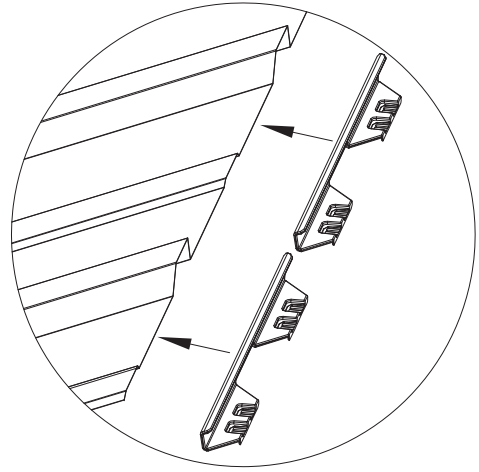

X2

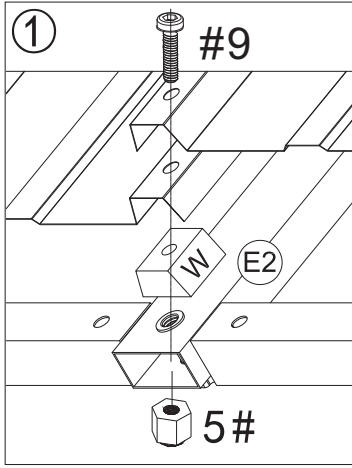

▲ Part #W should be inserted between roof panels and solidifying bar or beams, then secure with bolts and nuts.

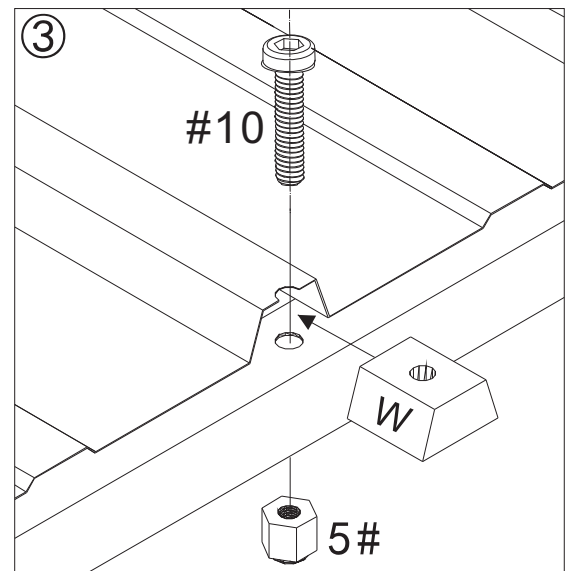
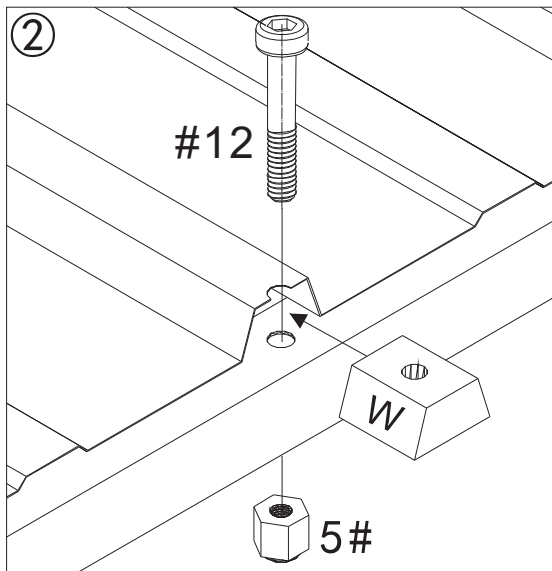
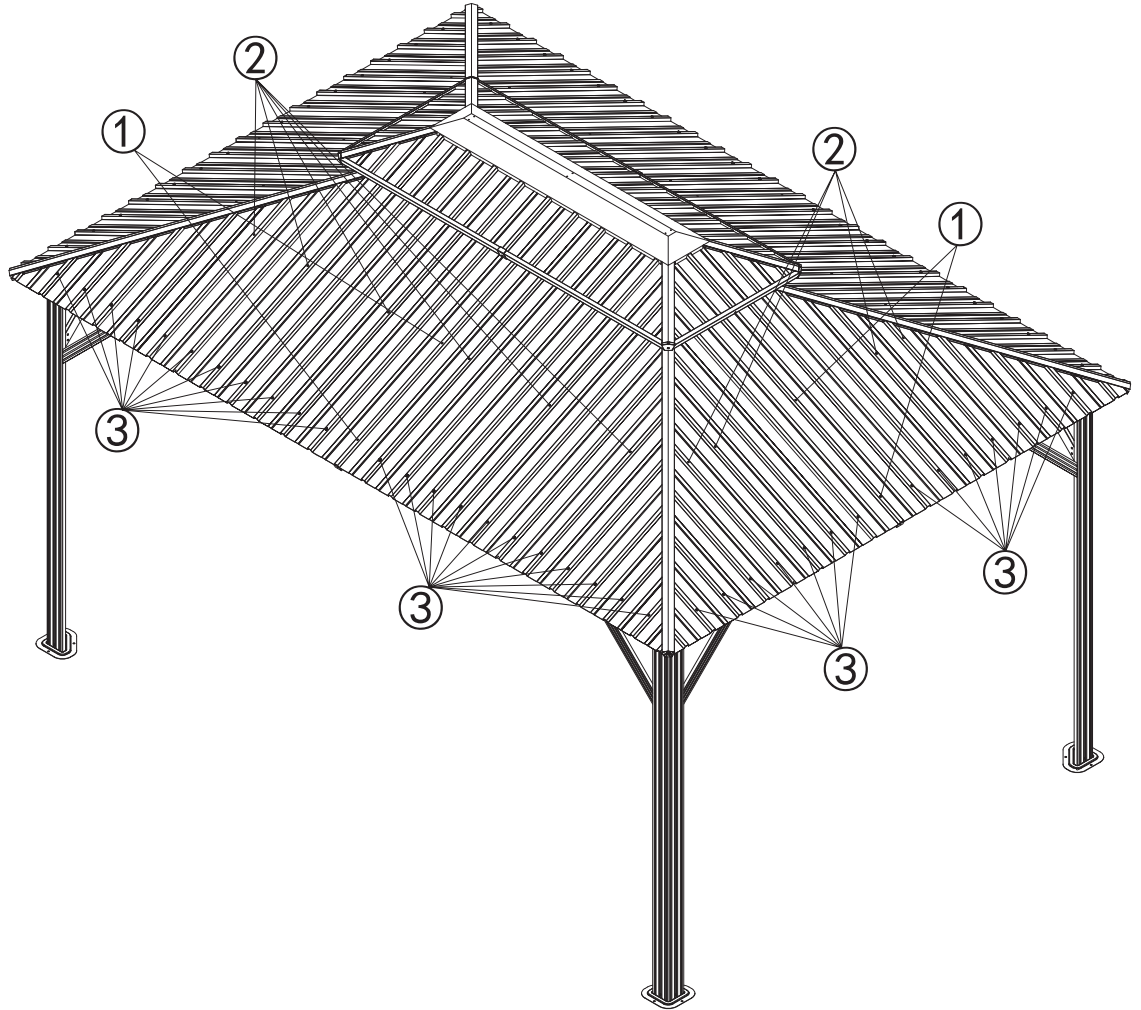

**ATTENTION:** The bigger roof panel need to cover the smaller one.

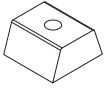

(W) 14x



(1) 1x



M6

(5) 14x



M6x28

(10) 12x



M6x50

(12) 2x

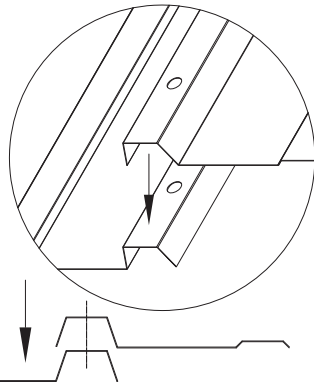

(1) Insert Part #P1,  
Part #P2 and Part #P3 into the frame.

(3) Place 1 Part #W between  
roof panels and solidifying bars.  
Then secure with 1 Bolt #12  
and 1 Nut #5.

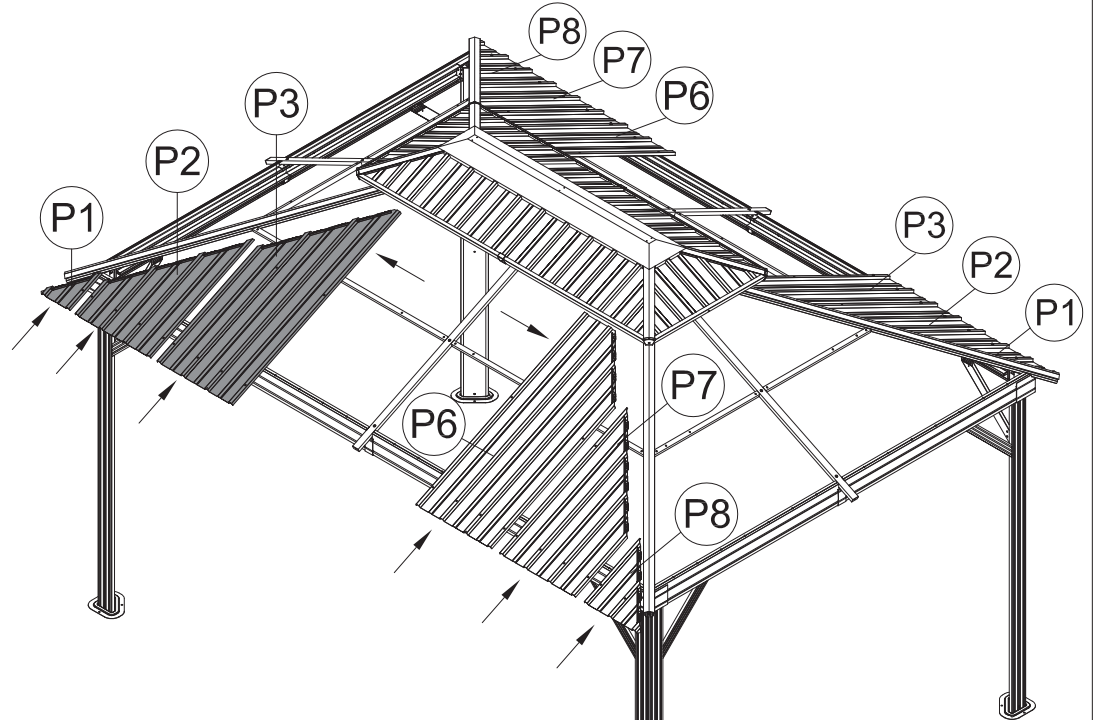
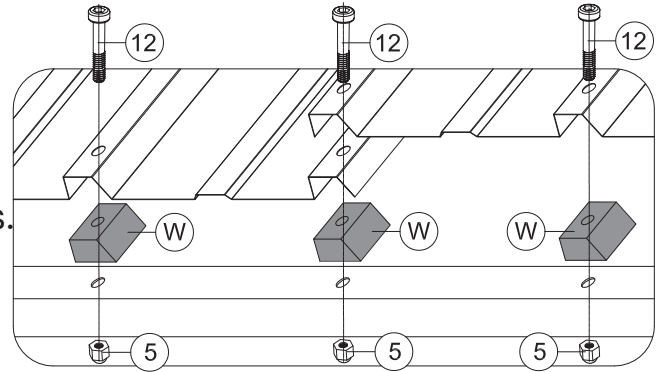

(2) Place 6 Part #W between  
roof panels and beams.  
Then secure with 6 Bolts #10  
and 6 Nuts #5.

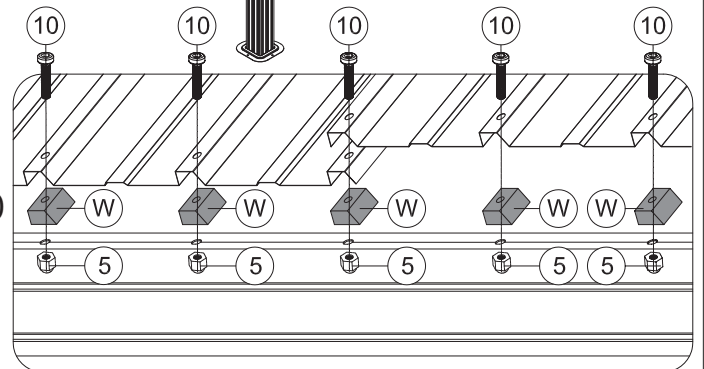

(4) Repeat the above procedures to assemble the opposite side.



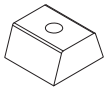

W 16x

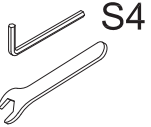

1 1x



M6

5 16x



M6x28

10 14x



M6x50

12 2x

**ATTENTION:** The bigger roof panel need to cover the smaller one.

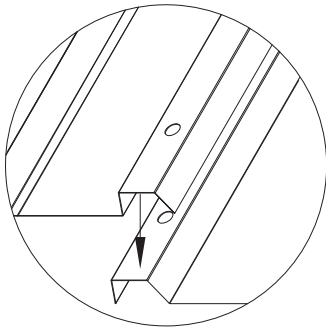

(1) Insert Part #P8,  
Part #P7 and Part #P6 into the frame.

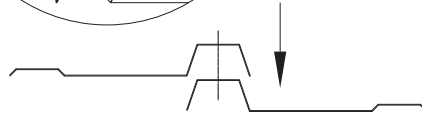

(3) Place 1 Part #W between  
roof panels and solidifying bars.  
Then secure with 1 Bolt #12  
and 1 Nut #5.

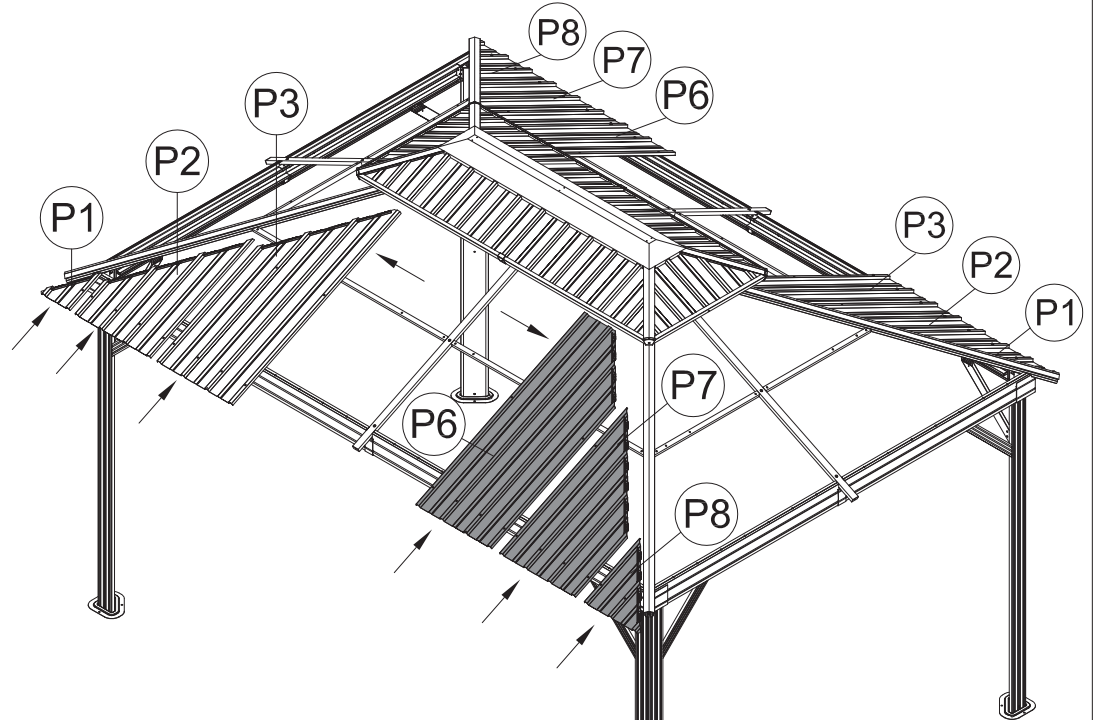
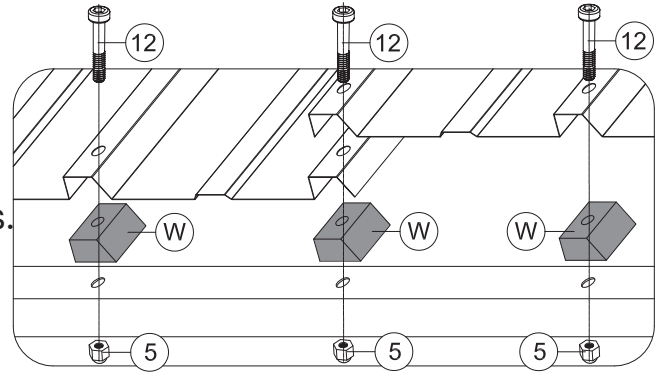

(2) Place 7 Part #W between  
roof panels and beams.  
Then secure with 7 Bolts #10  
and 7 Nuts #5.

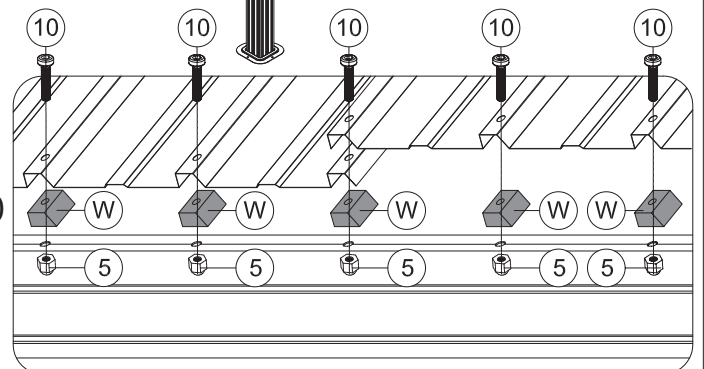

(4) Repeat the above procedures to assemble the opposite side.

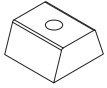

(W) 26x



(1) 1x



M6

(5) 26x



M6x28

(10) 18x

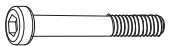

M6x50

(12) 8x

**ATTENTION: The bigger roof panel need to cover the smaller one.**

(1) Insert Part #P4 and Part #P5 into the frame.

(3) Place 4 Part #W between roof panels and solidifying bars. Then secure with 4 Bolts #12 and 4 Nuts #5.

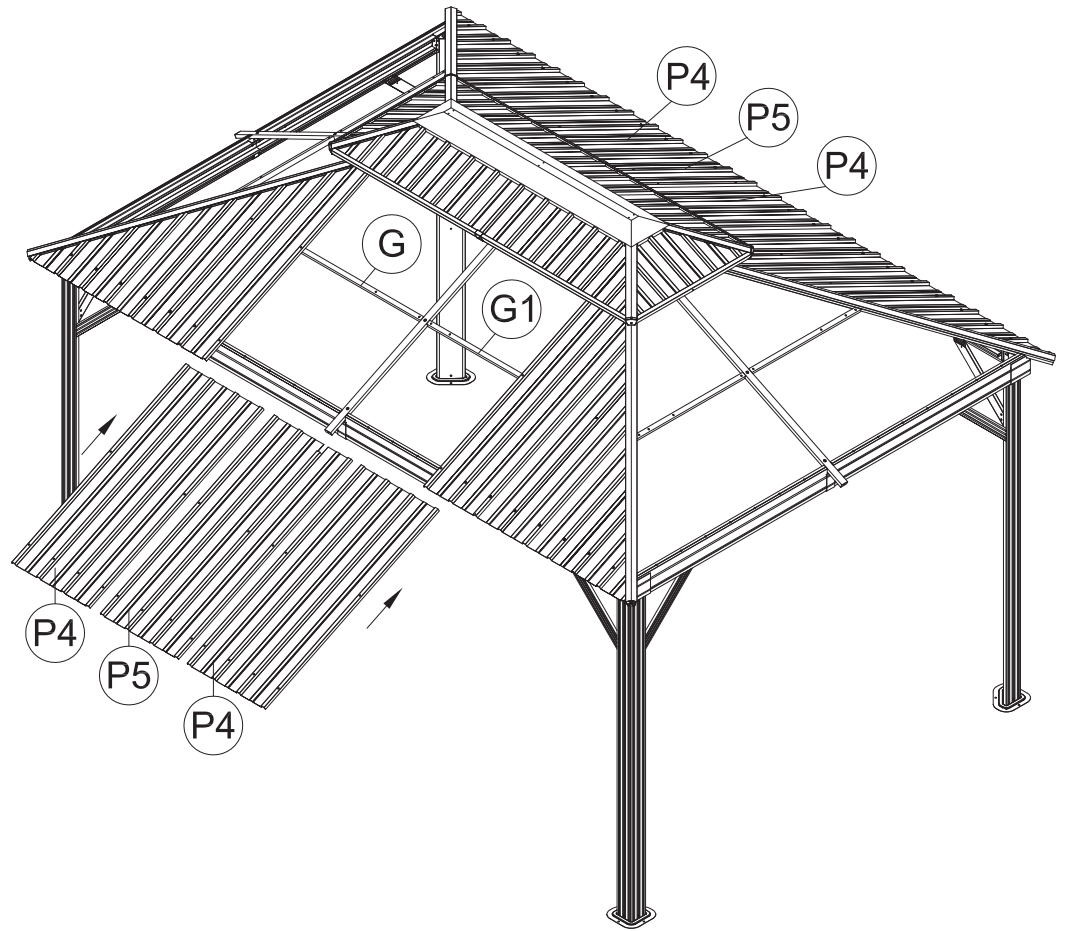
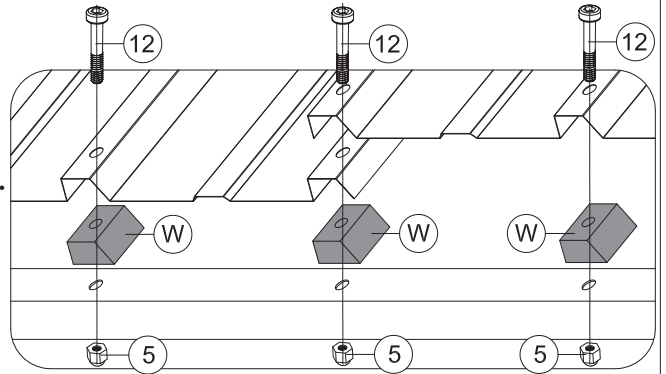

(2) Place 9 Part #W between roof panels and beams. Then secure with 9 Bolts #10 and 9 Nuts #5.

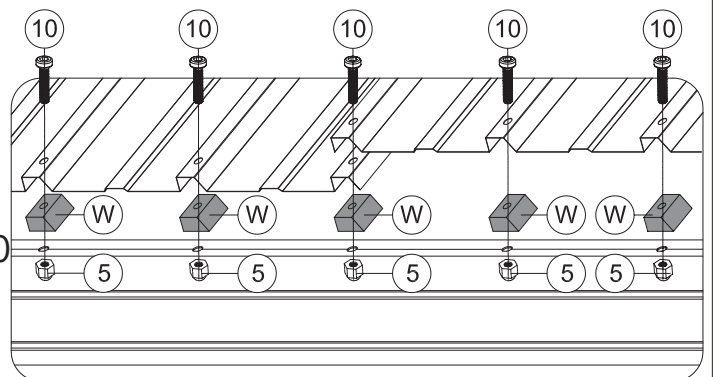

(4) Repeat the above procedures to assemble the opposite side.

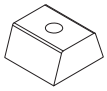

W 4x



1 1x

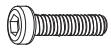

M6x25

9 4x

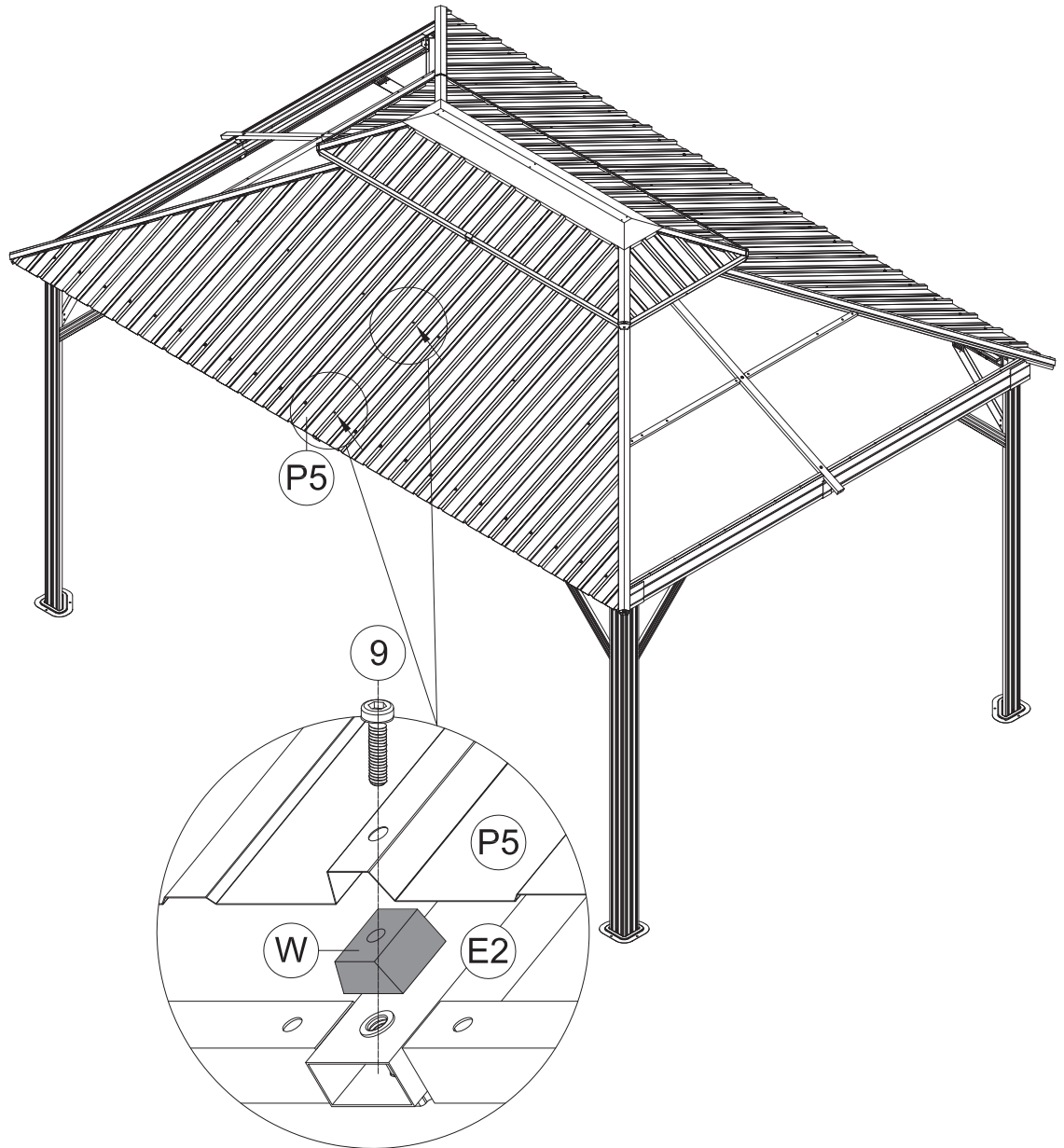

(1) Place 2 Part #W between Part #P5 and Part #E2.  
Then secure with 2 Bolts #9 and 2 Nuts #5.

(2) Repeat the above procedures to assemble the opposite side.

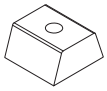

W 20x

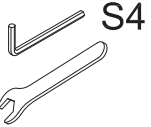

1 1x



M6

5 20x



M6x28

10 16x

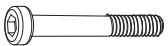

M6x50

12 4x

**ATTENTION:** The bigger roof panel need to cover the smaller one.

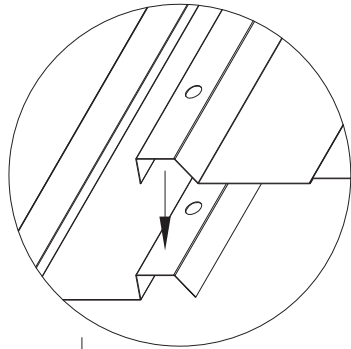

(1) Insert Part #M1 and Part #M2 into the frame.

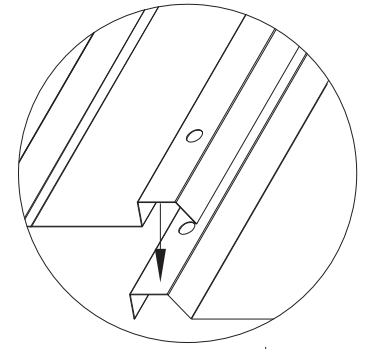

(2) Insert Part #M6 and Part #M5 into the frame.

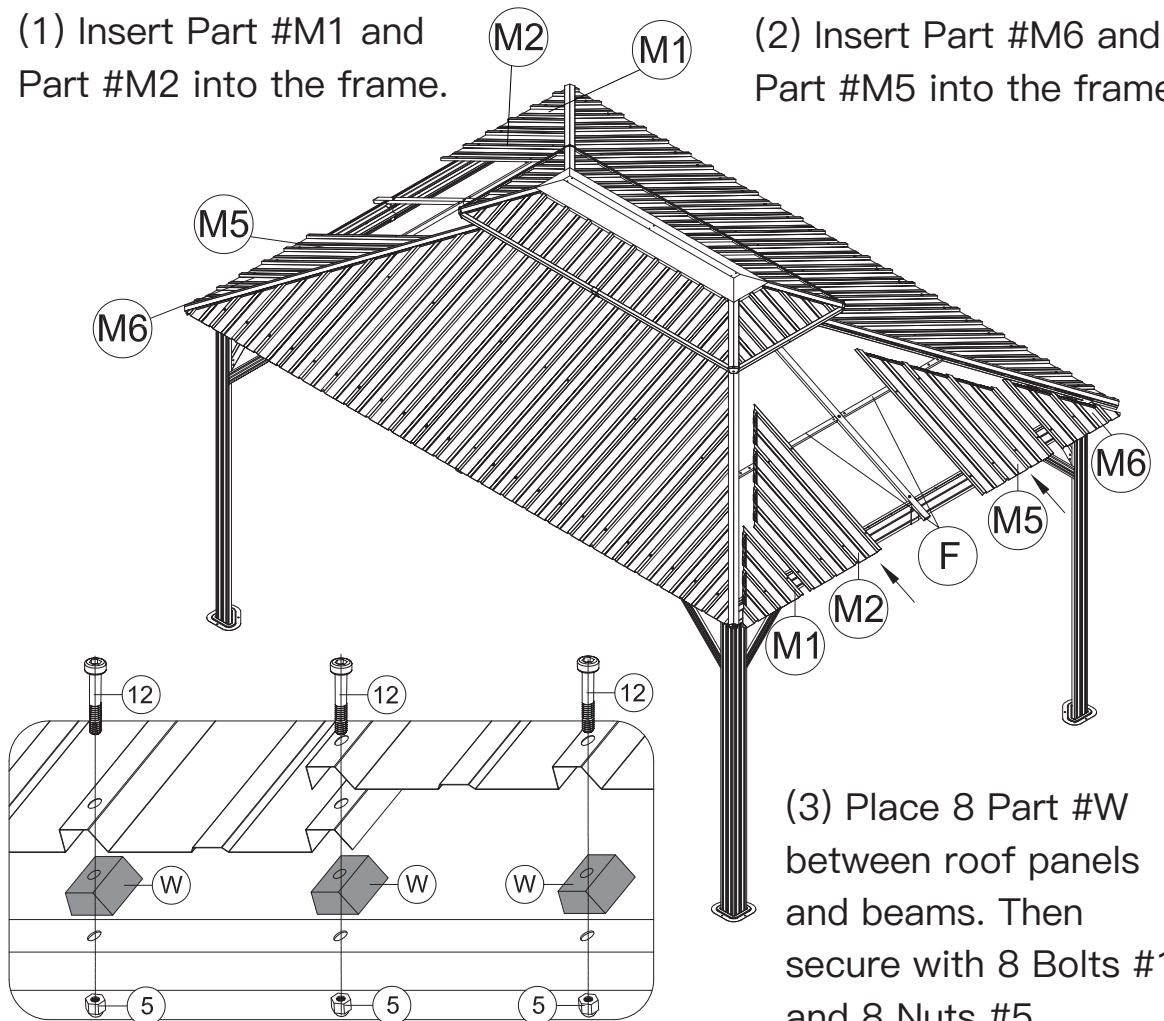

(3) Place 8 Part #W between roof panels and beams. Then secure with 8 Bolts #10 and 8 Nuts #5.

(4) Place 2 Part #W between roof panels and solidifying bars. Then secure with 2 Bolts #12 and 2 Nuts #5.

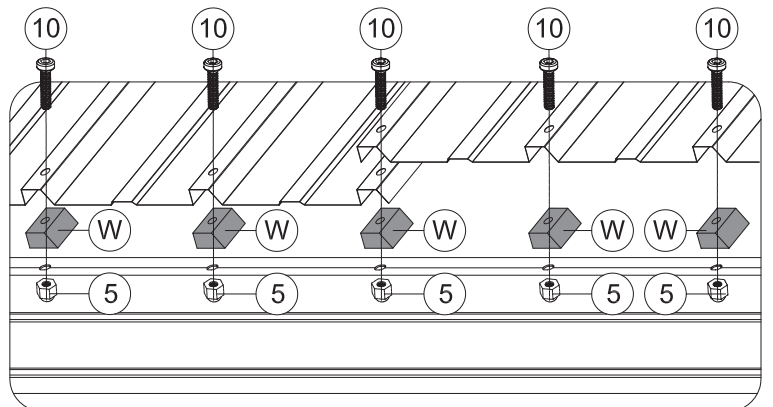

(5) Repeat the above procedures to assemble the opposite side.

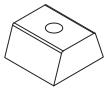

(W) 16x

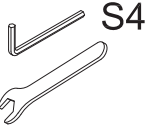

(1) 1x



M6

(5) 16x



M6x28

(10) 12x

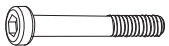

M6x50

(12) 4x

**ATTENTION: The bigger roof panel need to cover the smaller one.**

(1) Insert Part #M3 into the frame.

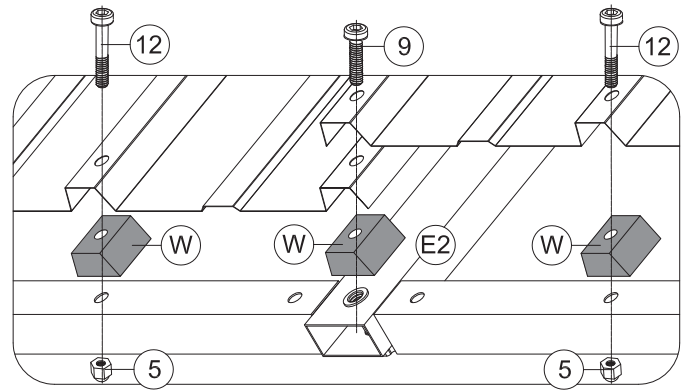
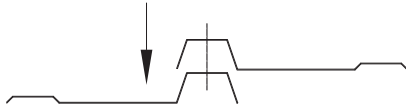

(3) Place 2 Part #W between roof panels and solidifying bars. Then secure with 2 Bolts #12 and 2 Nuts #5.

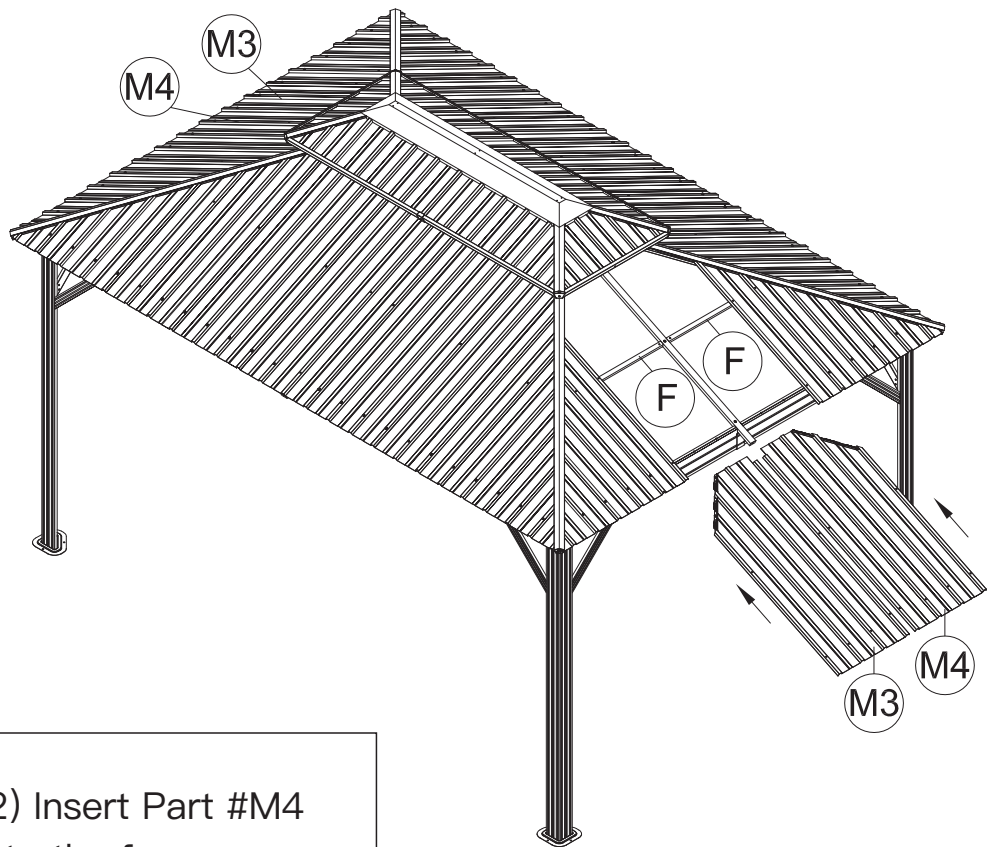

(2) Insert Part #M4 into the frame.

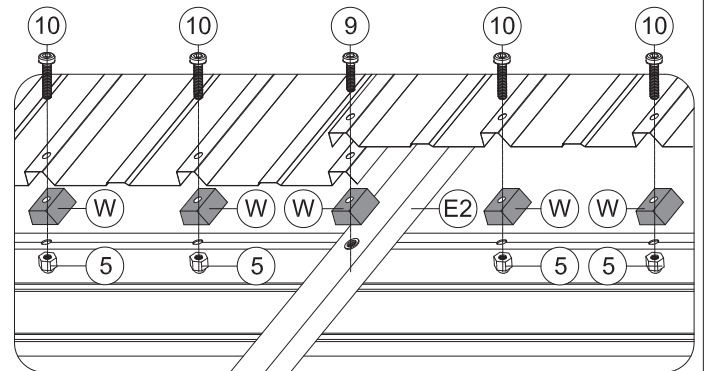
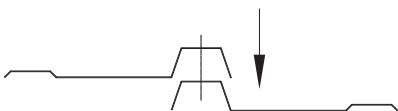

(4) Place 6 Part #W between roof panels and beams. Then secure with 6 Bolts #10 and 6 Nuts #5.

(5) Repeat the above procedures to assemble the opposite side.

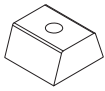

W 4x

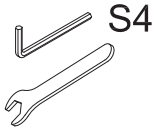

1 1x

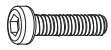

M6x25

9 4x

(1) Place 2 Part #W between roof panels and Part #E2. Then secure with 2 Bolts #9 and 2 Nuts #5.

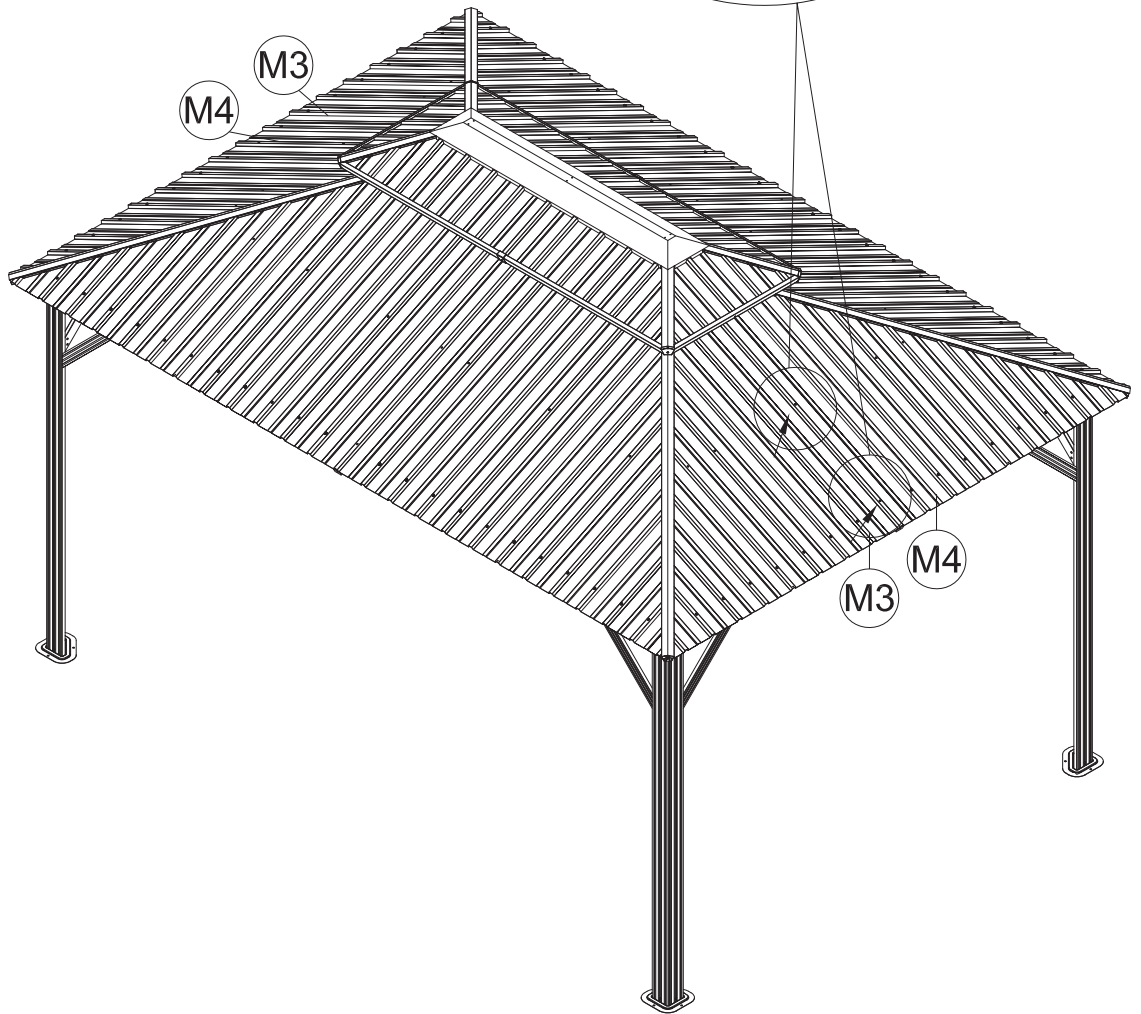
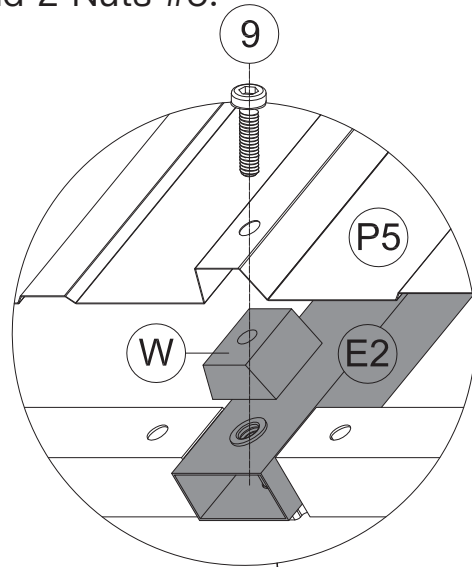

(2) Repeat the above procedures to assemble the opposite side.

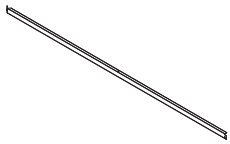

(K2) 2x

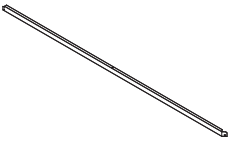

(K3) 2x



(X2) 2x



(1) 1x



M6x16

(8) 2x

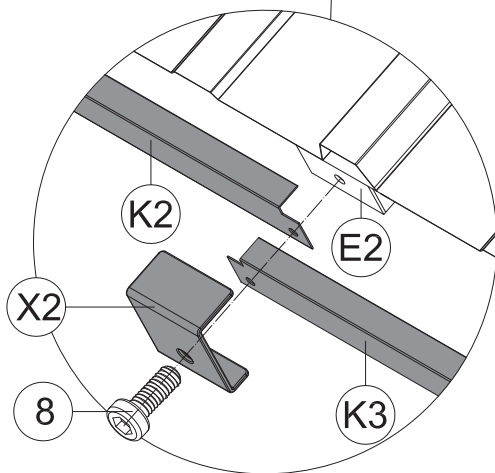
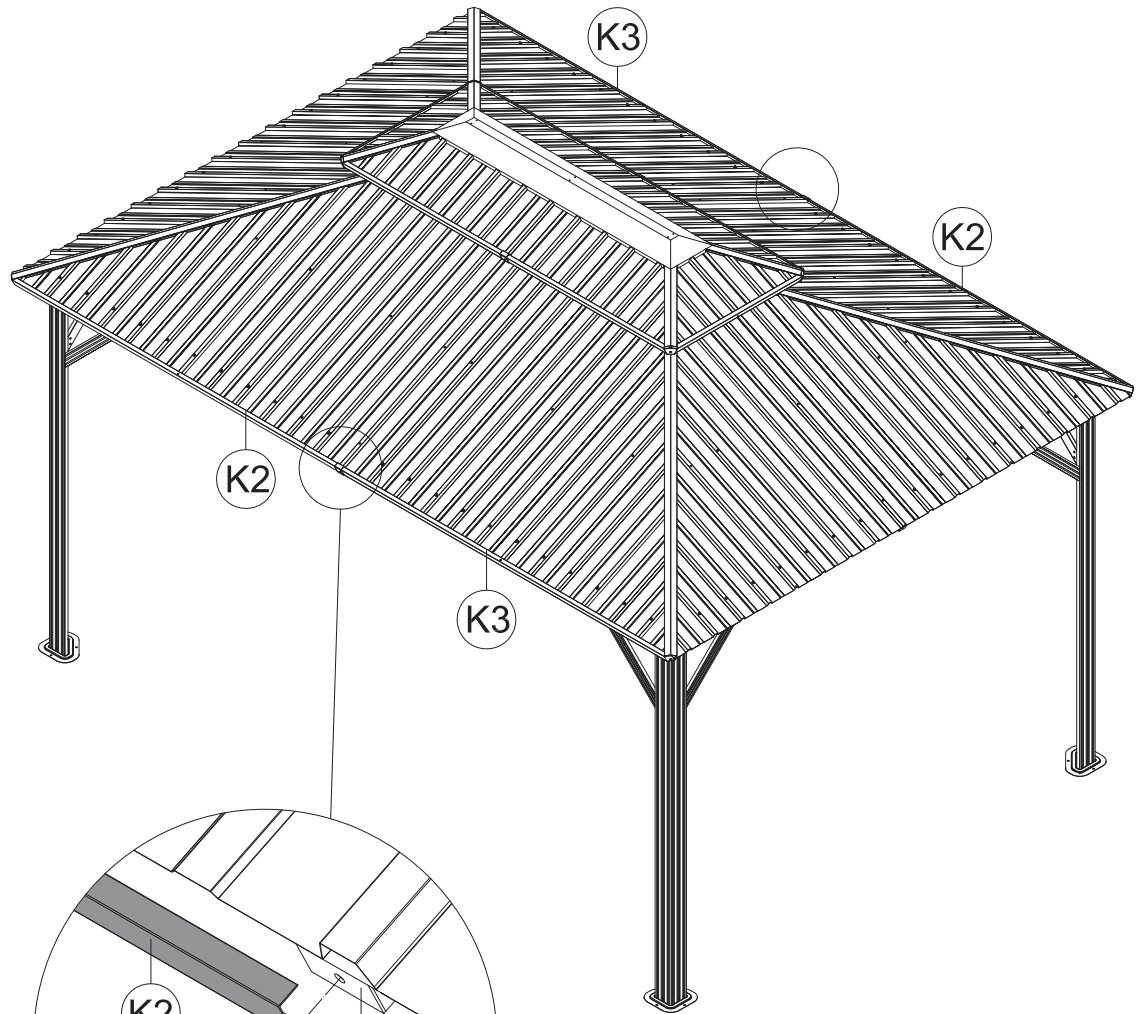

(1) Place Part #K2 and Part #K3 on Part #E2;  
Put on Part #X2 and secure with Bolt #8.

(2) Repeat the above procedures to assemble the opposite side.

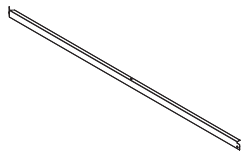

(K) 2x

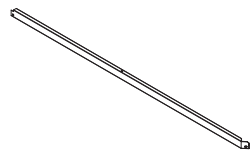

(K1) 2x



(X2) 2x



(1) 1x



M6x16

(8) 2x

(1) Place Part #K and Part #K1 on Part #E2;  
Put on Part #X2 and secure with Bolt #8.

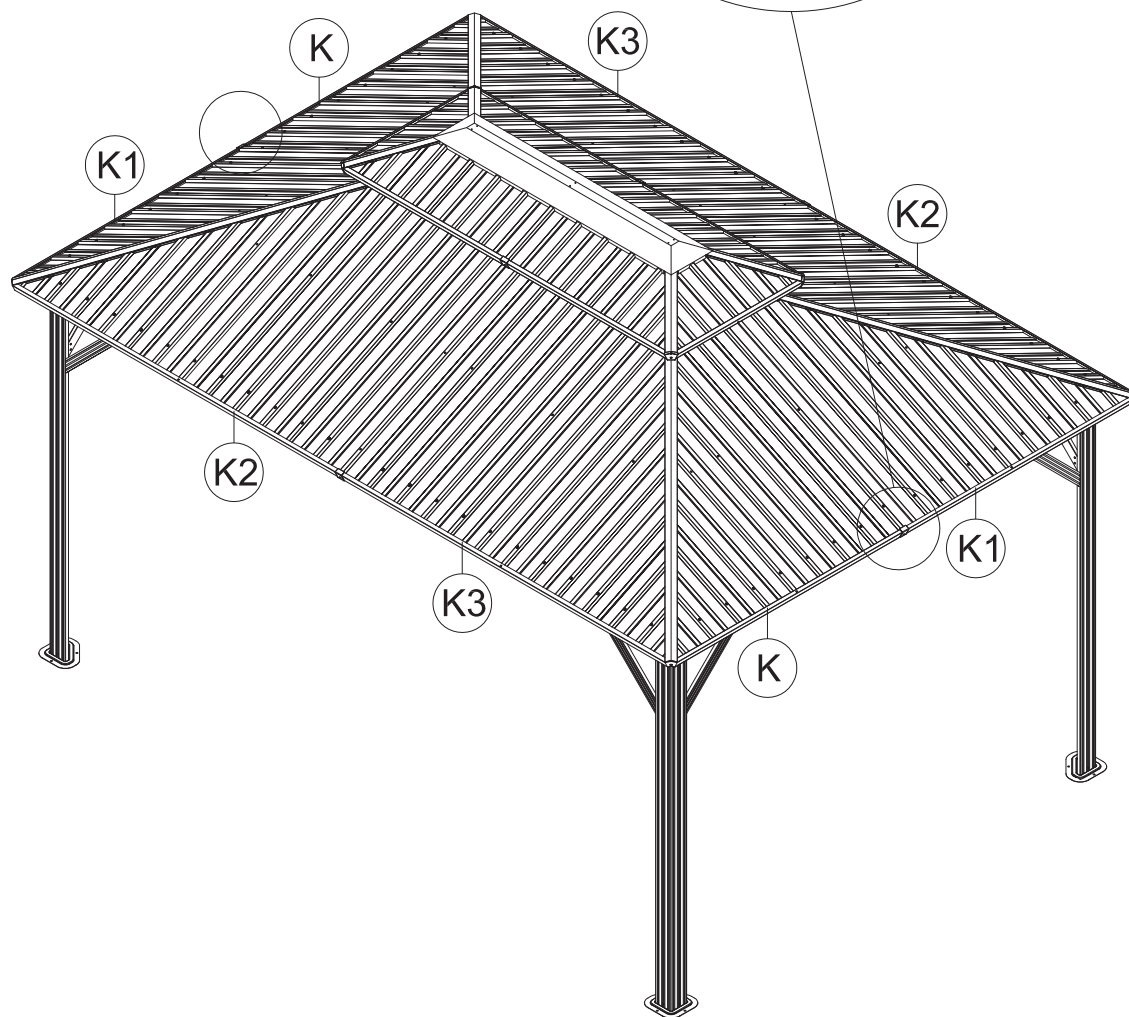
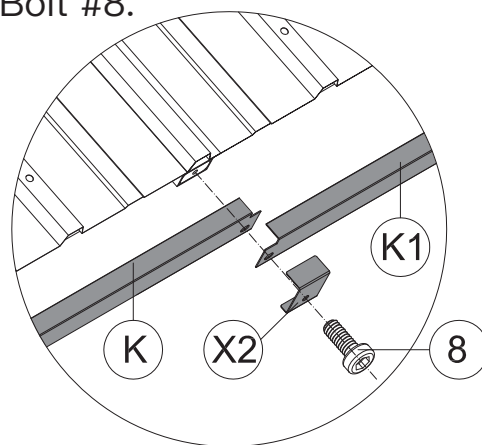

(2) Repeat the above procedures to assemble the opposite side.





X3 4x



1 1x



ST6.3x15

2 4x

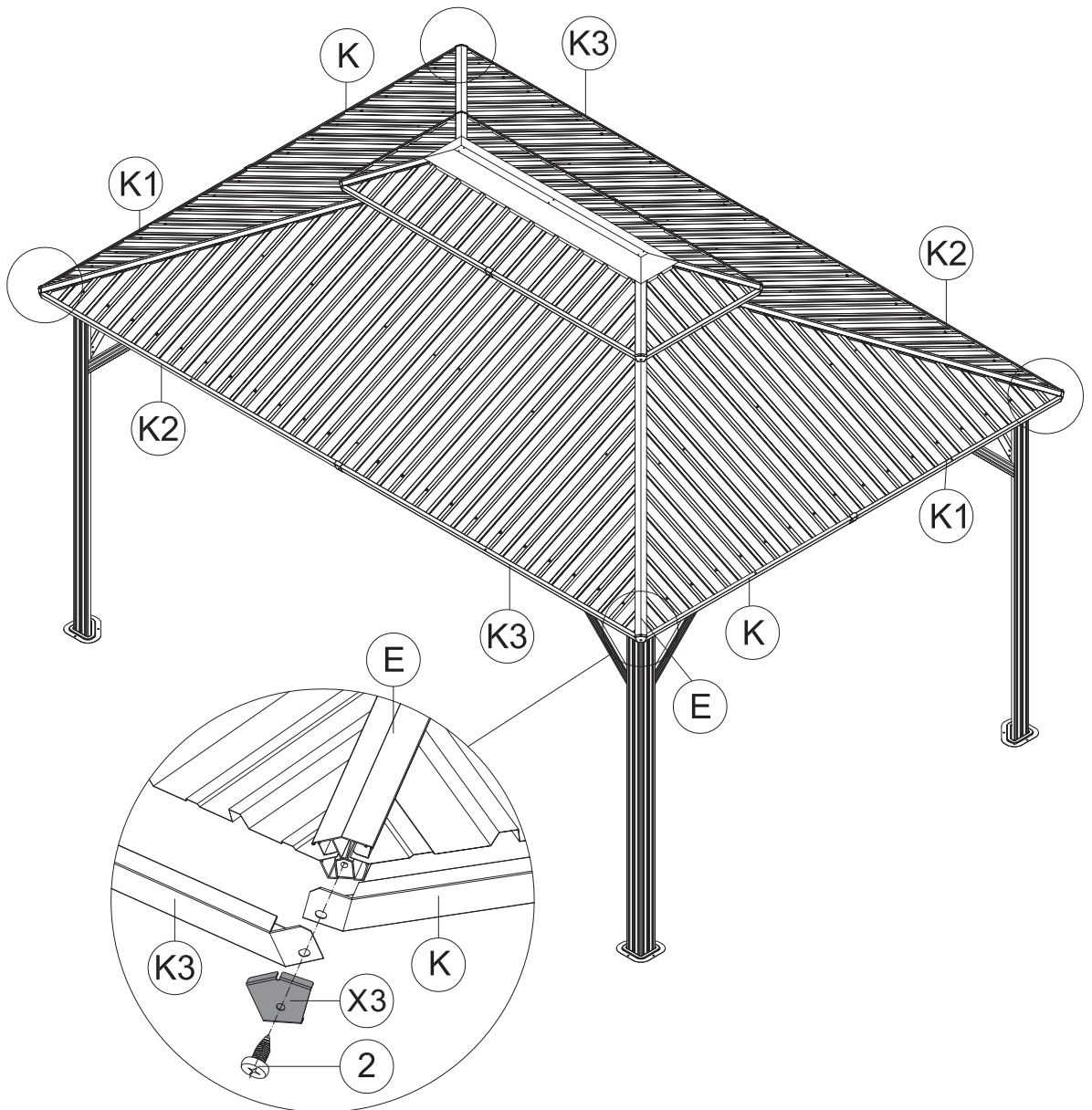

(1) Place Part #K3 and Part #K on Part #E;  
Put on Part #X3 and secure with Self-tapping Screw #2.

(2) Repeat the above procedures to assemble the other 3 corners.



ST5x16

3

8x

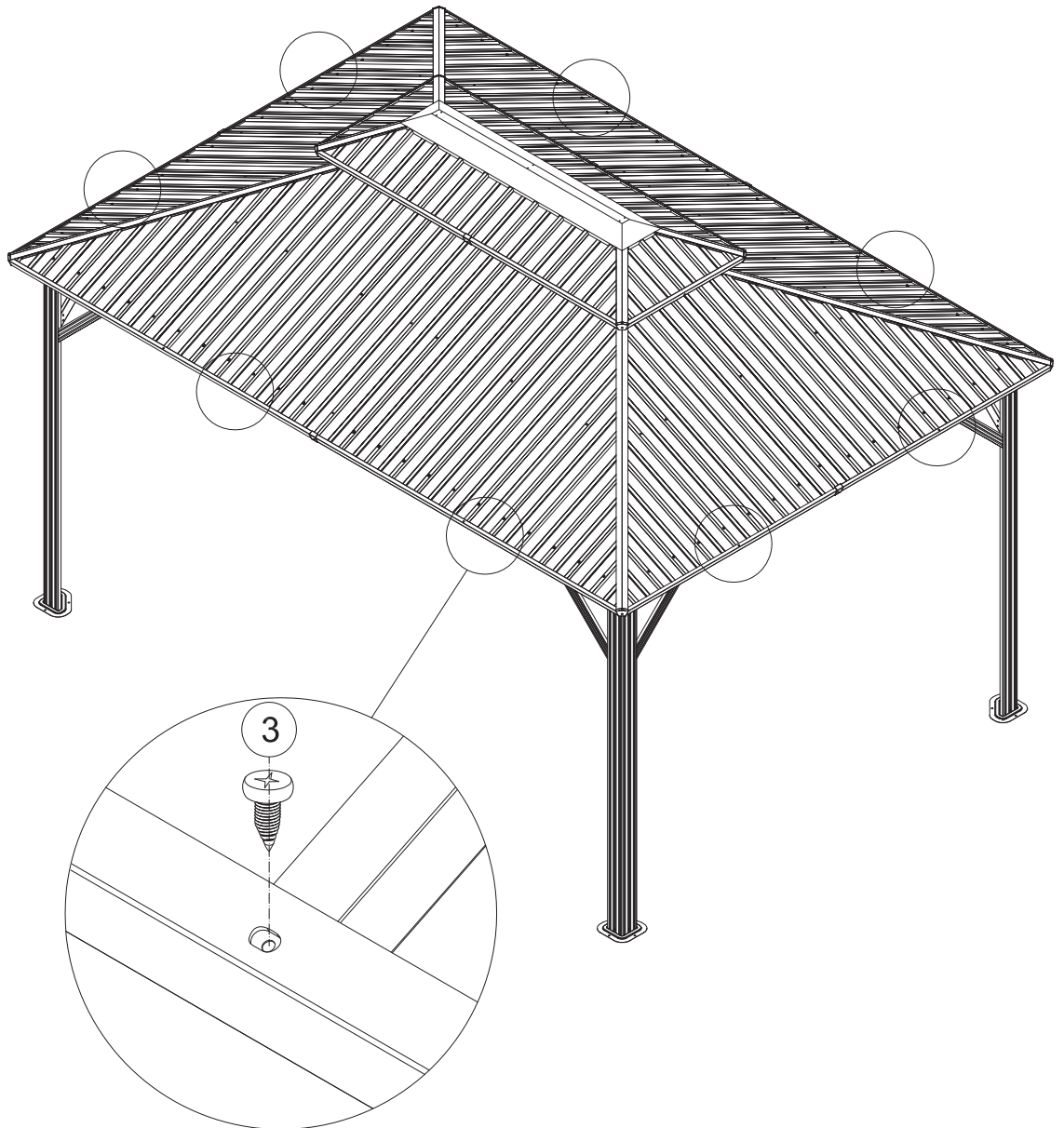

(1) Attach roof panels to finishing bars with 2 Self-tapping Screws #3.

(2) Repeat the above procedures to assemble the other 3 sides.

# How to Put the 112 Hooks into the Double-track

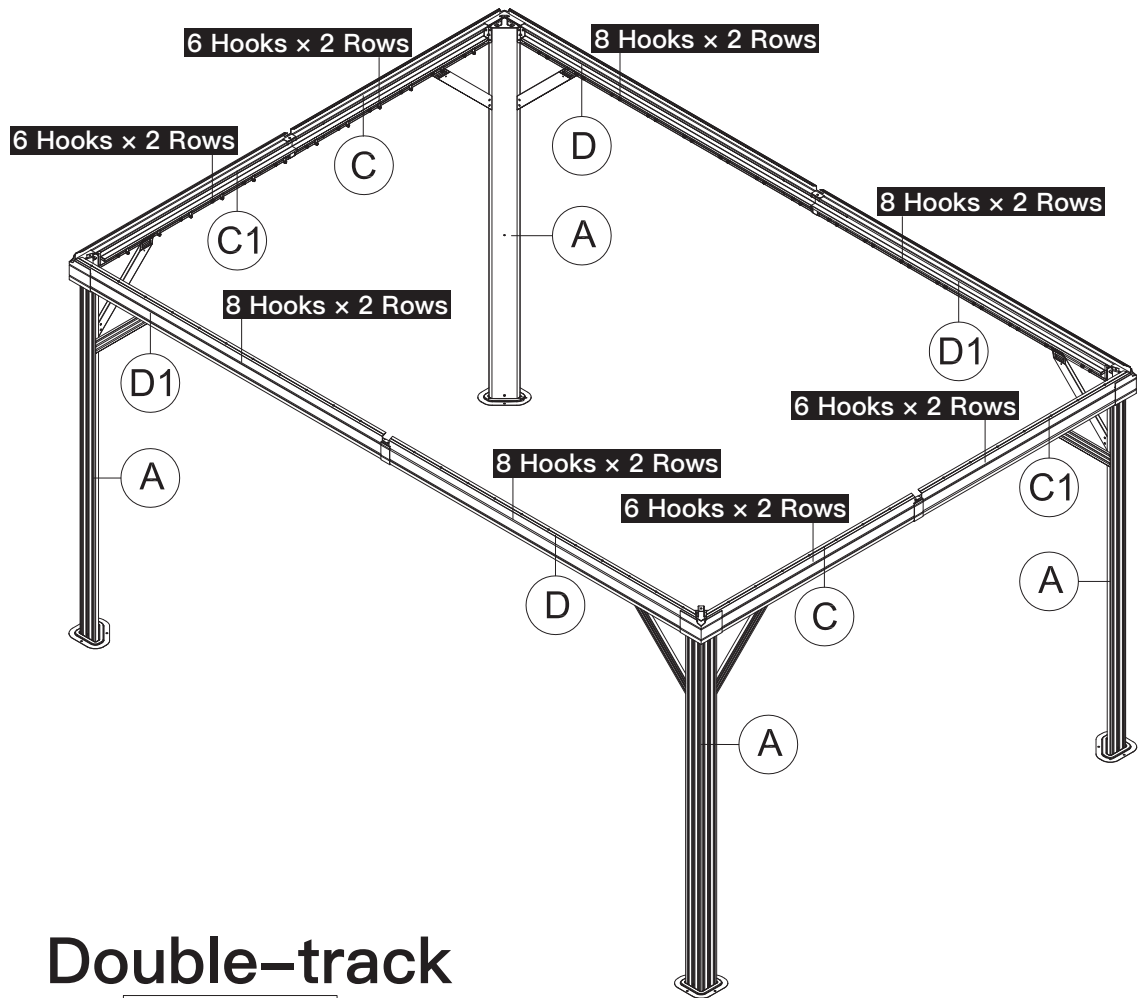

## Double-track

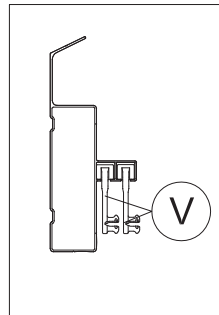

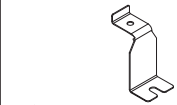

T1 2x



V 48x



1 1x

(1) Place 6 hooks on each slot of the Sidewall Track(C1&C).

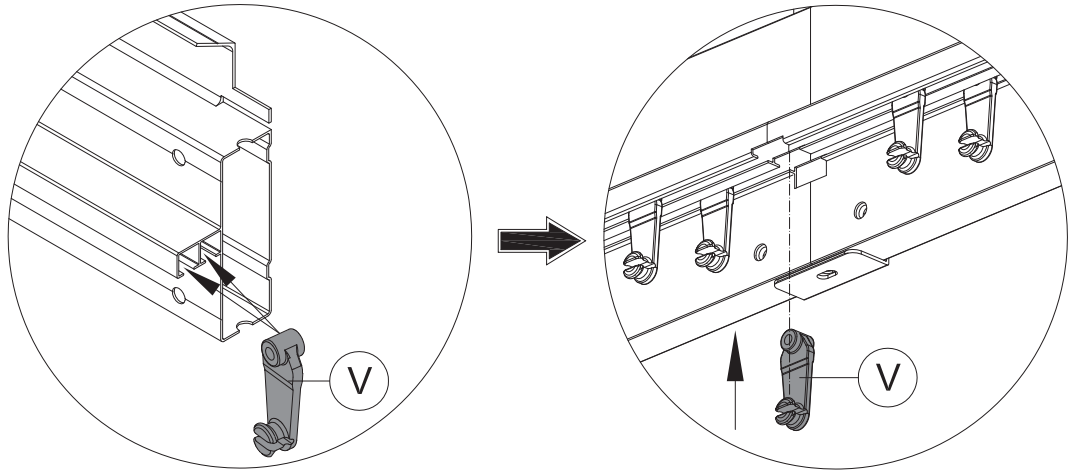

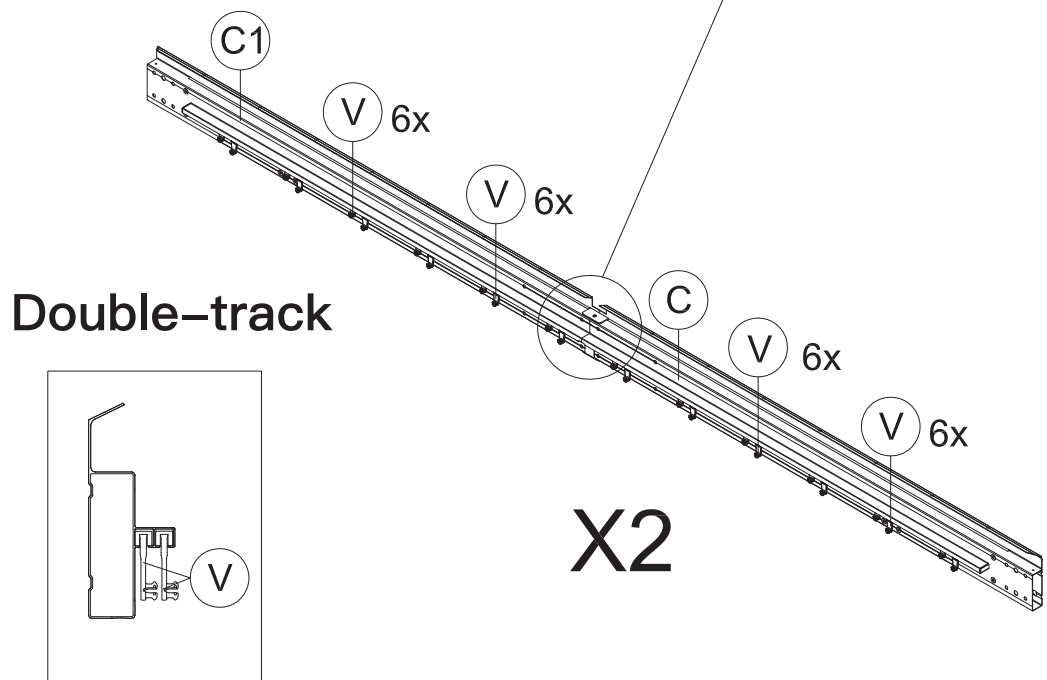
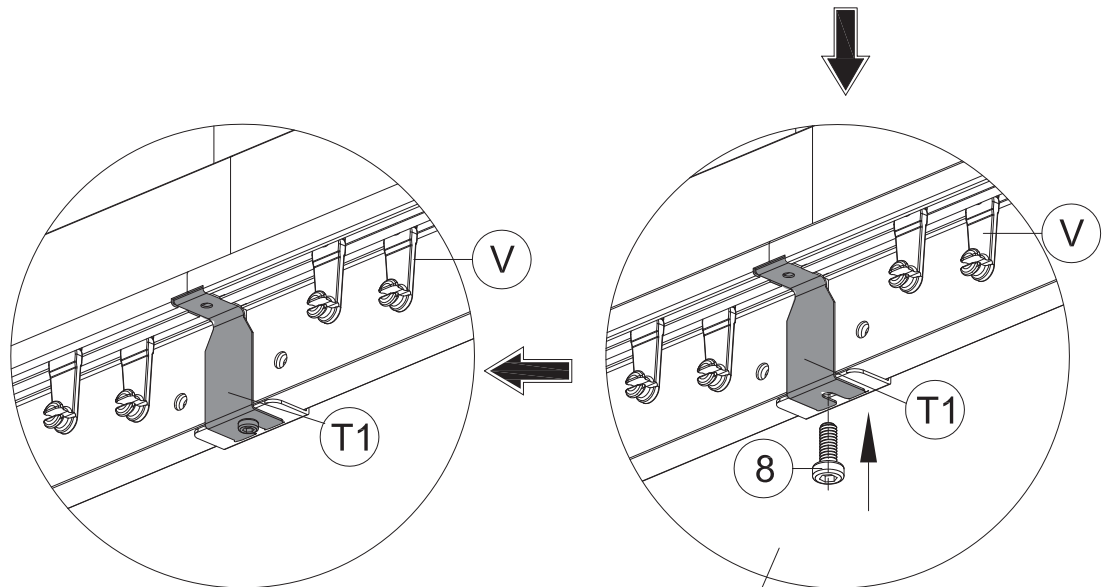

(2) Install Part #T1 at the joint of Part C&C1 with Bolt #8.



Double-track

X2

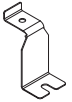
(3) Repeat the above procedures to assemble the opposite side.

-  T1 2x
-  V 64x
-  S4
- 1 1x

(1) Place 8 hooks on each slot of the Sidewall Track(D&D1).

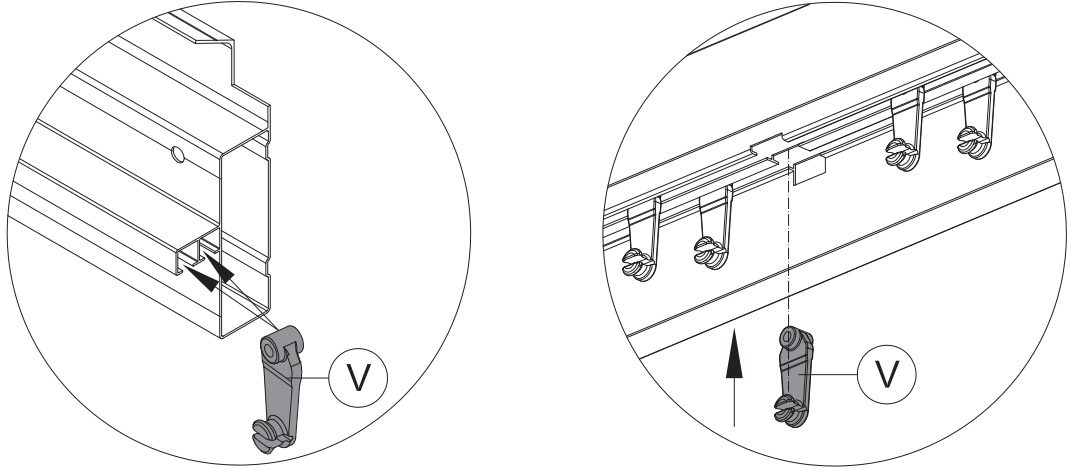

(2) Install Part #T1 at the middle of Part D&D1 with Bolt #8.

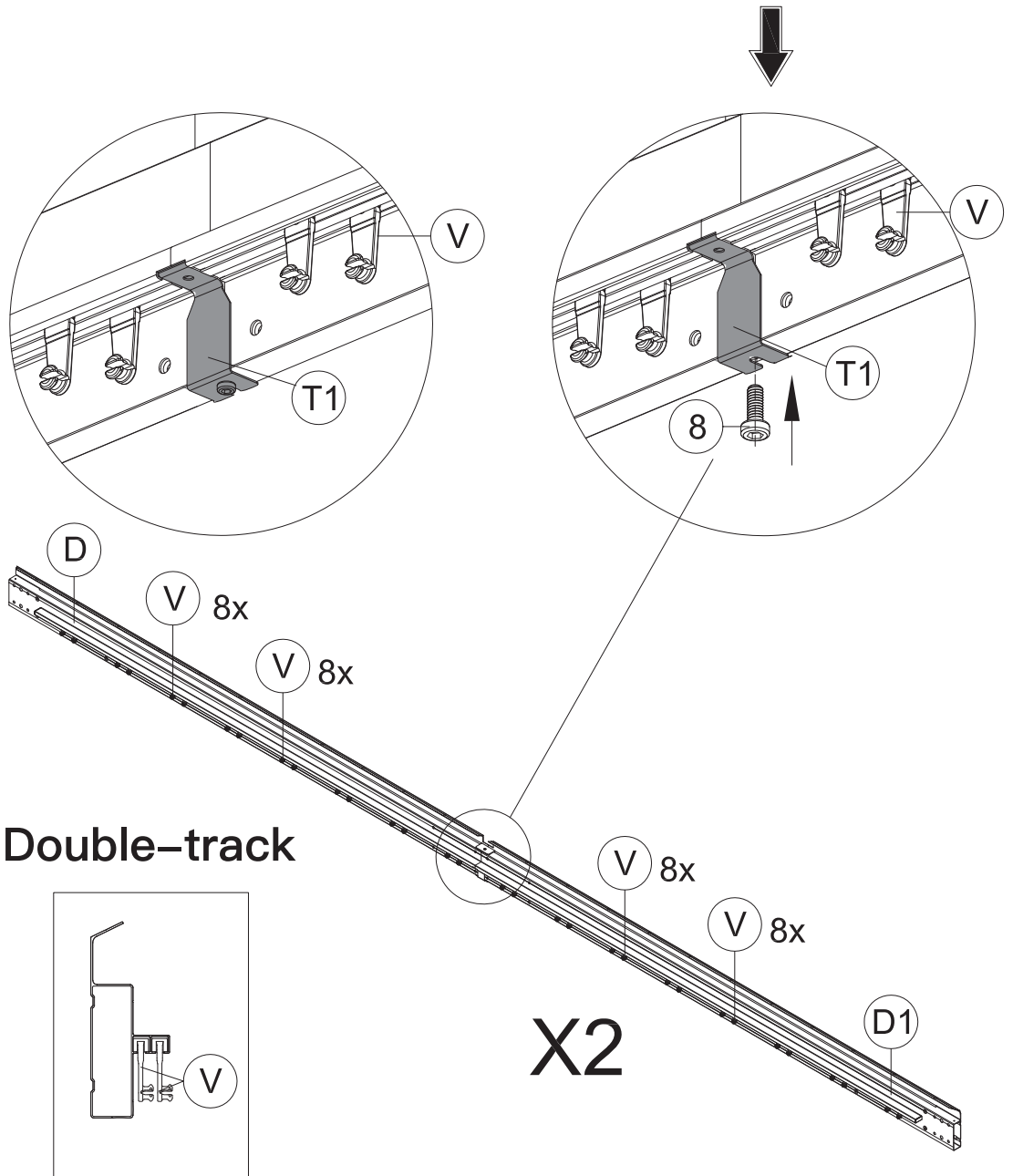

(3) Repeat the above procedures to assemble the opposite side.



Y1 4x

# Hang up Mosquito Sidewalls to **Inside Track**

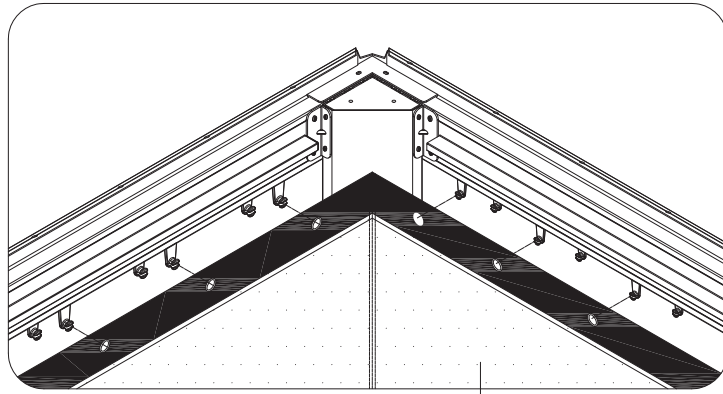

Y1

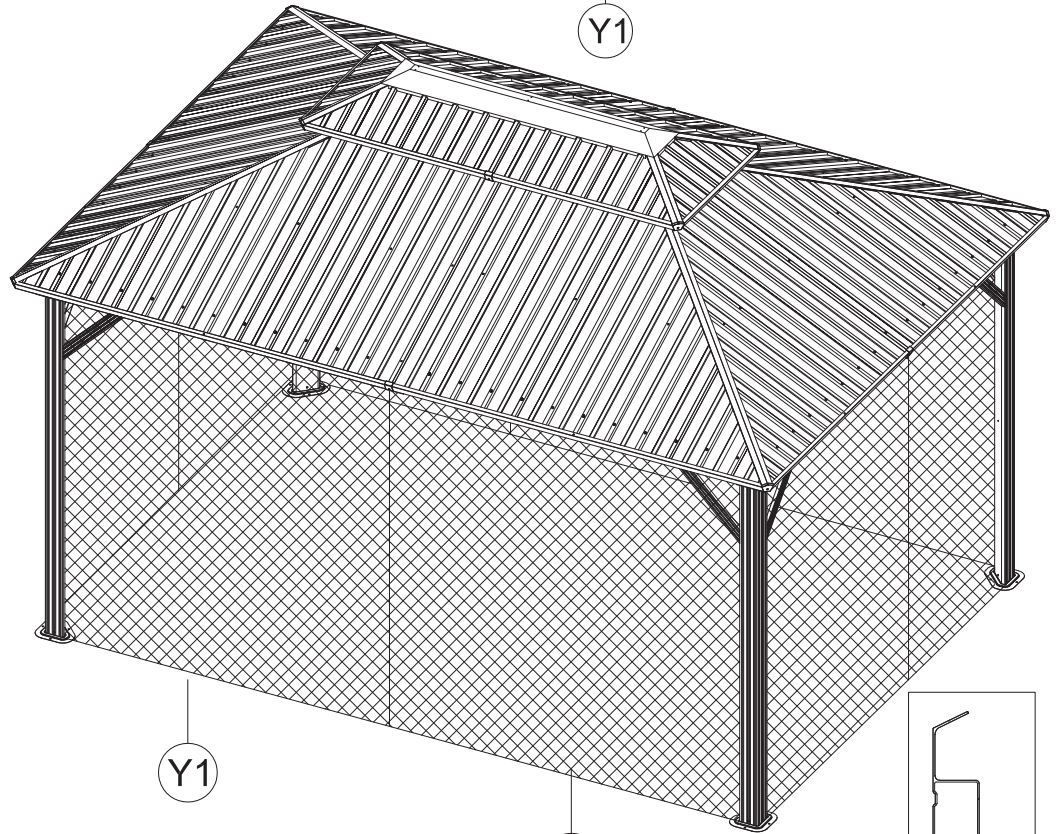

Y1

Y1

Y1

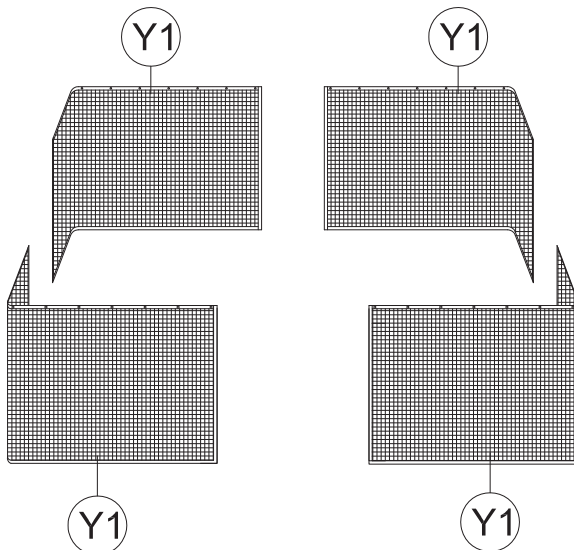
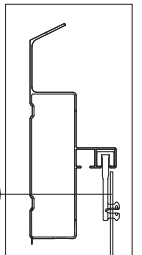

Y1

Y1

Y1

Y1

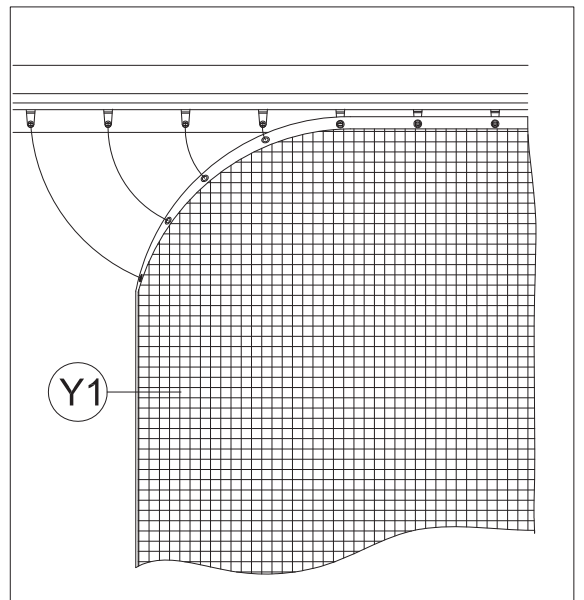

Y1

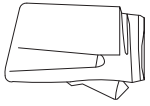

# Hang up Solid Sidewalls to **Outside Track**

Y 4x

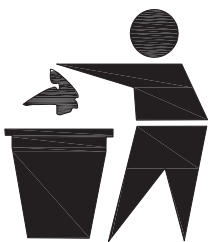
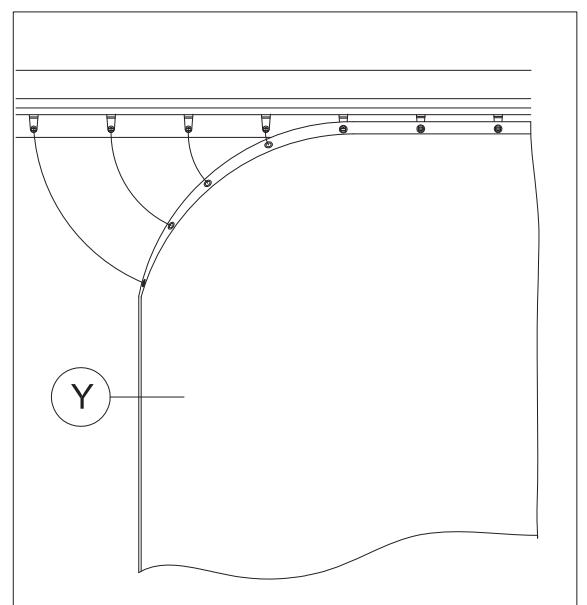
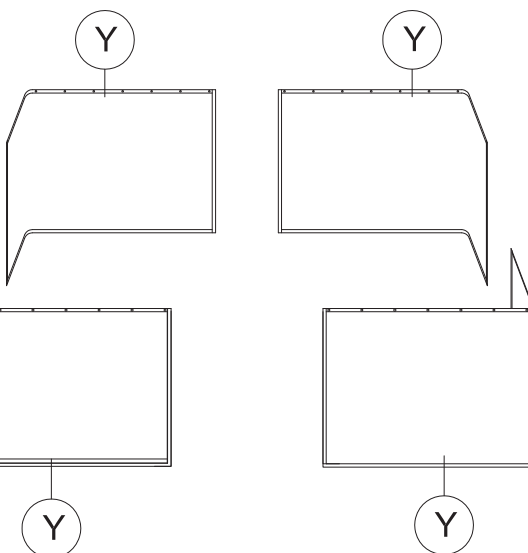
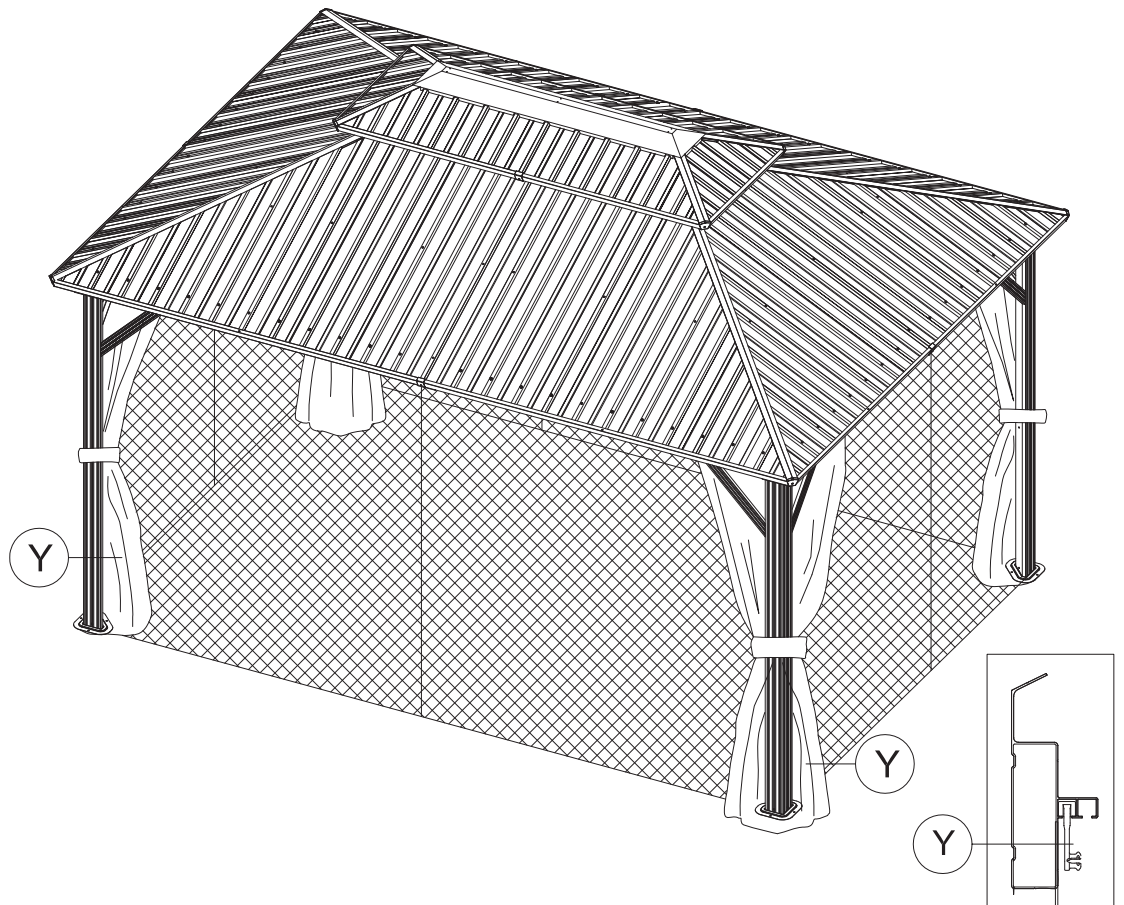
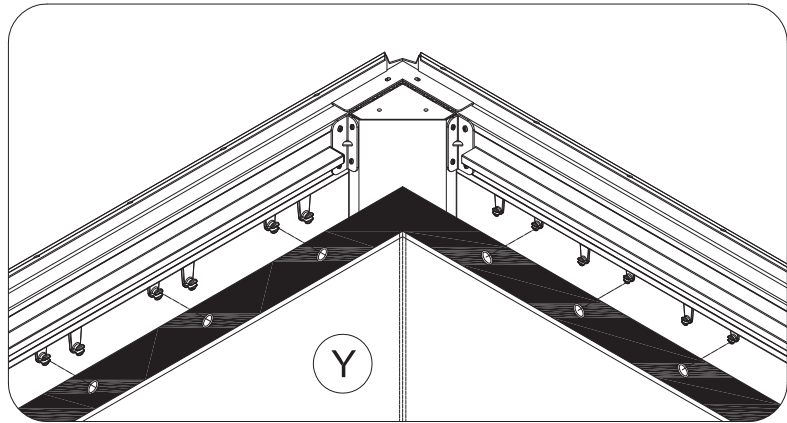

# Thanks for your purchase.

At domi outdoor living, we believe in our products.

That's why we provide a 12-month warranty and

friendly, easy-to-reach after-sales service. So if you

have any questions about our product and assembly-

,please feel free to contact us. We will be here for you.

**Support:**  

**After-sales contact email:**

[service@domioutdoorliving.com](mailto:service@domioutdoorliving.com)

Please tell us your order ID when contact.

Attach photos of damaged part for instant reply.