

ASSEMBLY INSTRUCTION

Accent Chair

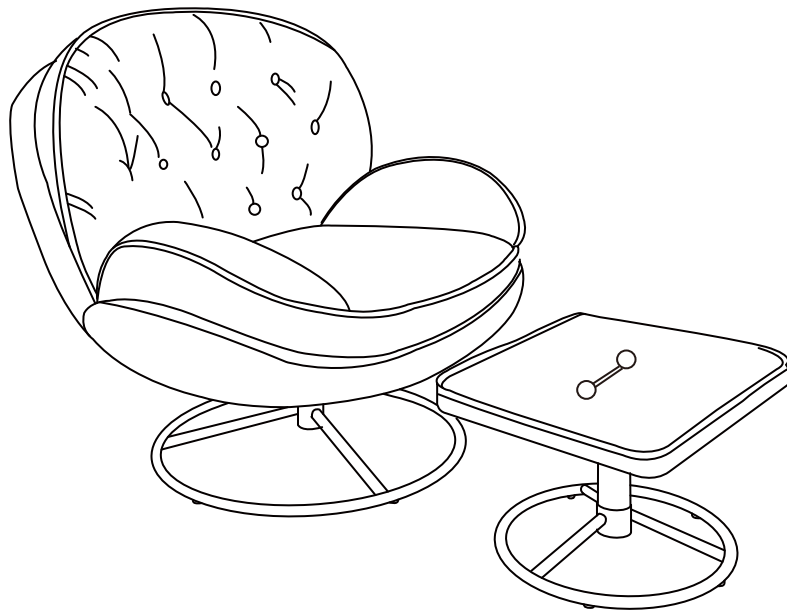



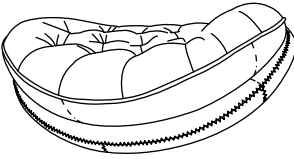
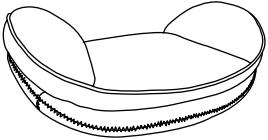
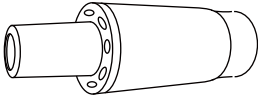
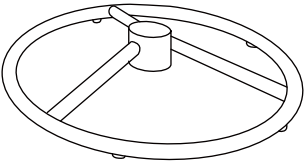
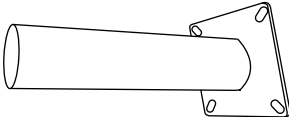
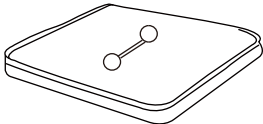
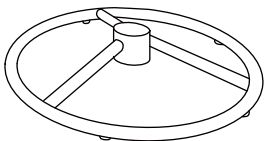

DY-WX18841 -2-1PC



Component List

LABEL		DESCRIPTION	QTY
A		Chair Back	1
B		Chair Seat	1
C		Gas Lift	1
D		Chair Base	1
E		Metal Rooy	1
F		Footrest Gushion	1
G		Footrest Base	1

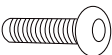
Hardware List

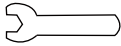
LABEL		DESCRIPTLON	QTY
H1		Hanger Bolts	3
H2		Hex Nut	3
H3		Flat Washer	3
H4		Spring Washer	3
H5		Bolts	4
H6		Allen Key	1
H7		Wrench	1

Assembly Steps

1

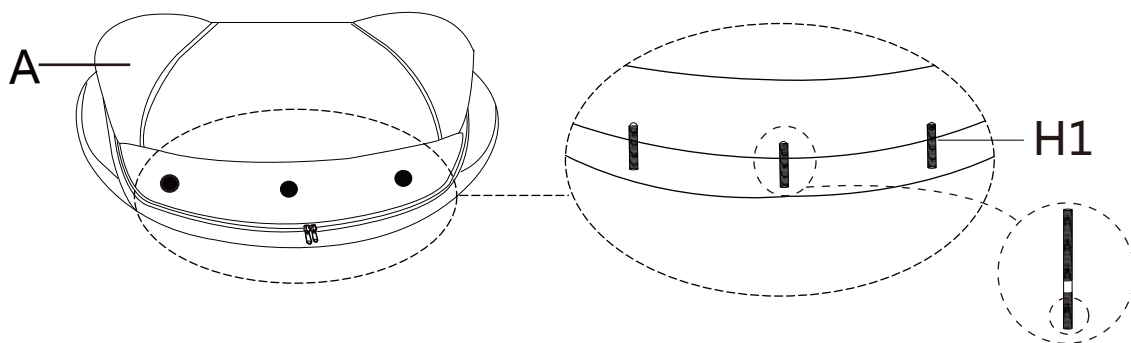

place chair back (A) on a clean padded surface, fasten bolt (H1) to insert on bottom edge of the chair back (A)

Assembly Steps

2

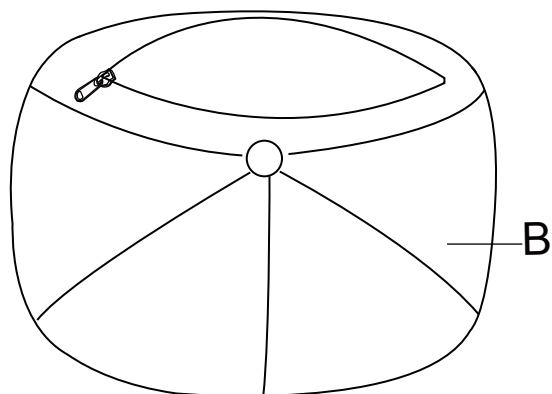

Open zipper pocket under the chair seat (B)

3

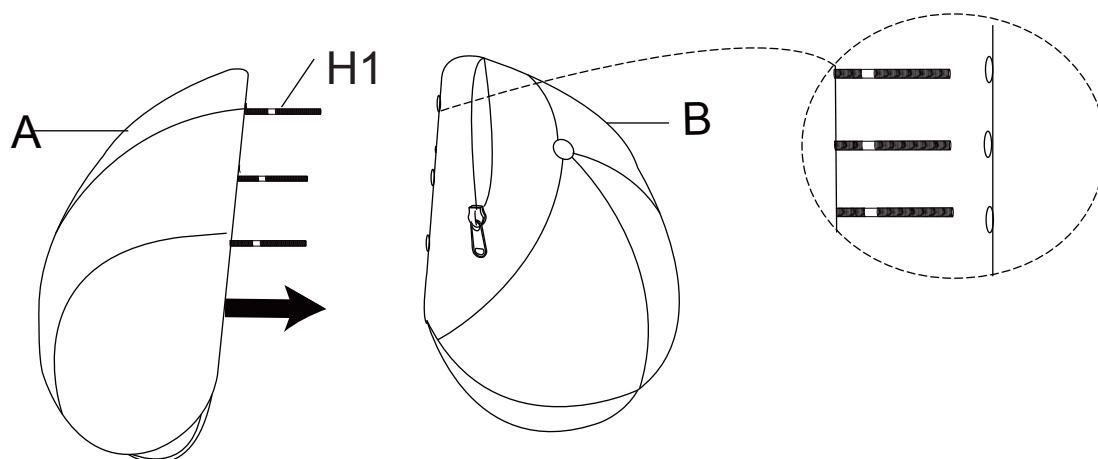

Carefully align then insert bolts through holes on edge of chair seat (B)

Assembly Steps

4

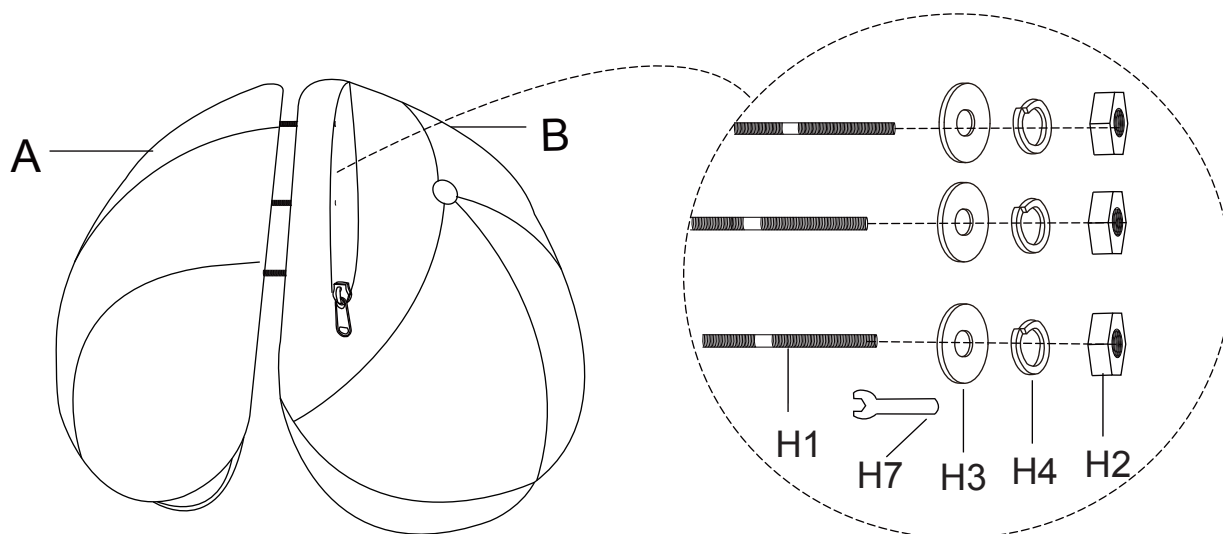

Pierce the non-woven fabric on the inside of chair B
Attach flat washer (H3), spring washer (H4), hex nut (H2) to bolts (H1)
then fasten to secure.

5

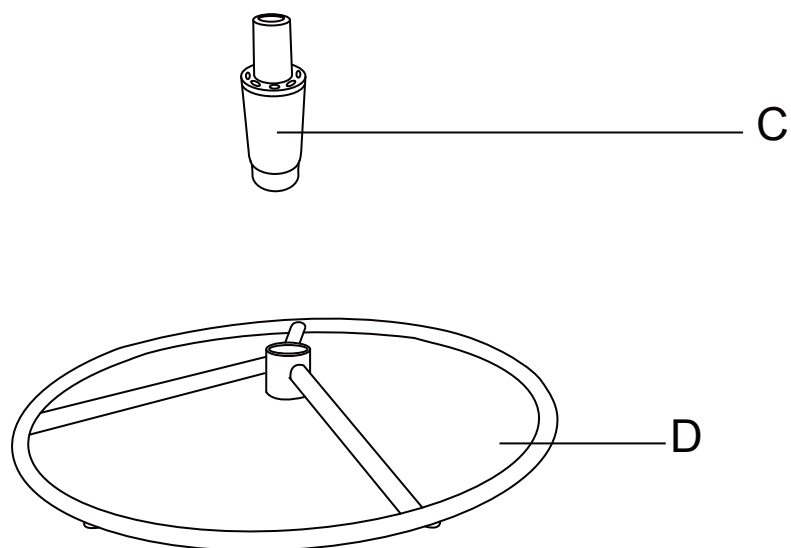

Insert lift (C) to the metal base (D)

Assembly Steps

6

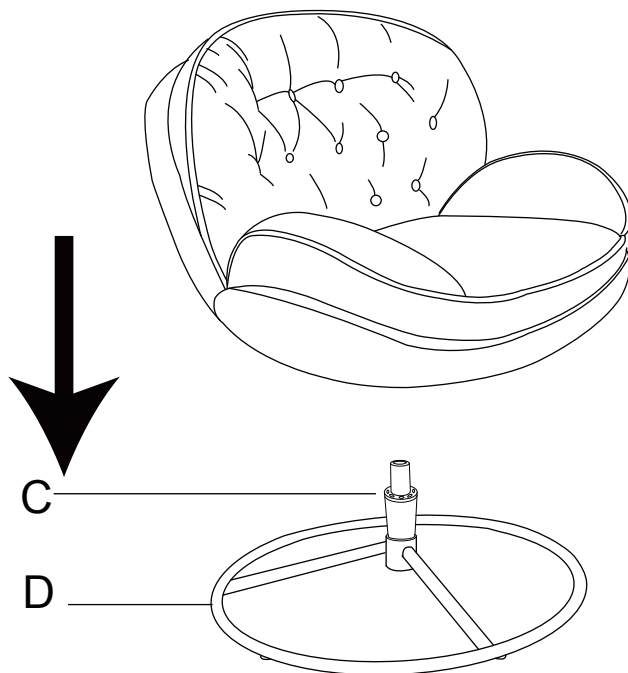

Carefully align center post (C) with hole on bottom of the chair seat (B)

7

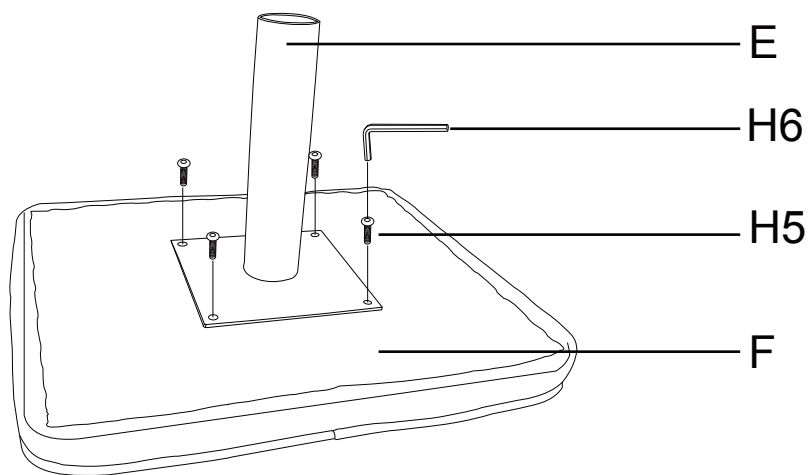

Then assembly the metal rod (E) to footrest frame with bolts (H5).

Assembly Steps

8

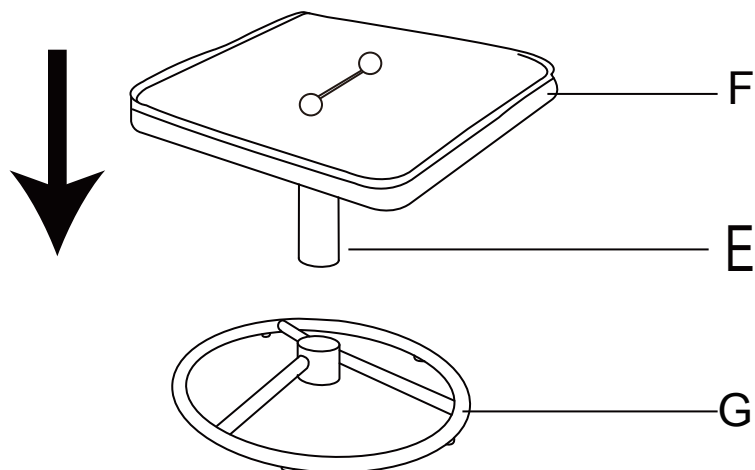

Insert the metal rod (E) into the footrest base.

9



Assembly completed