

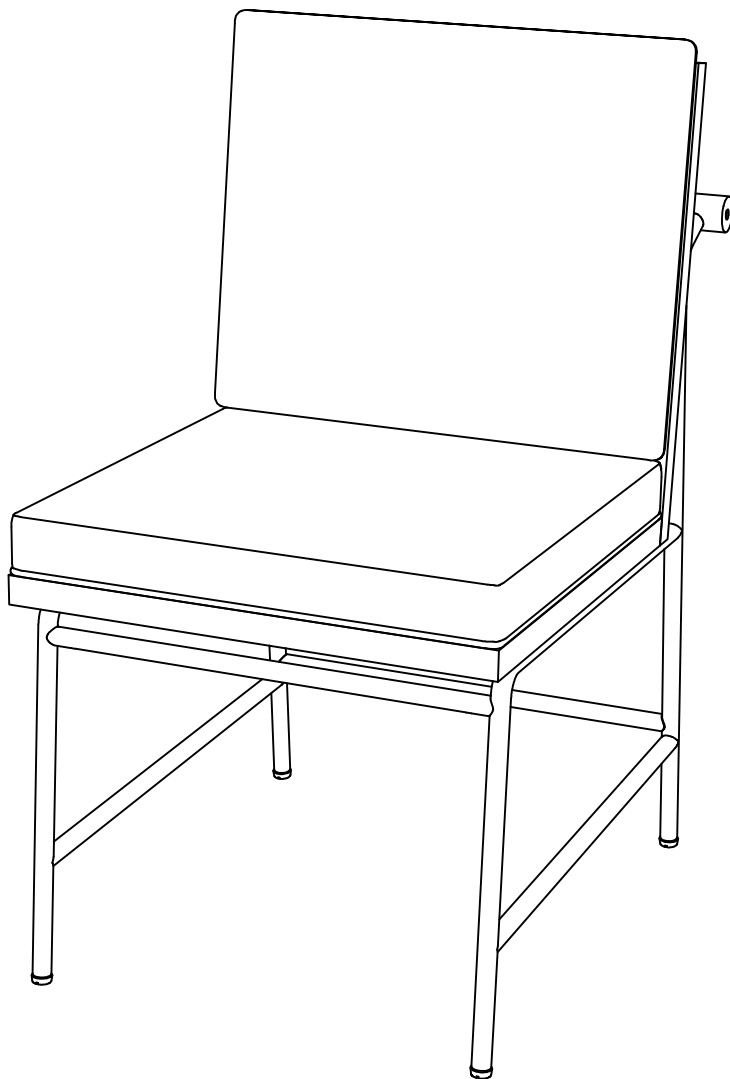

ASSEMBLY INSTRUCTION

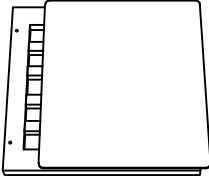

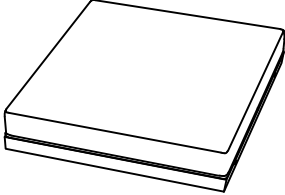

Dining chair
TN-1912

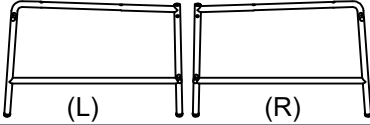
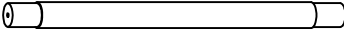
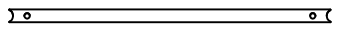

Component List

LABEL		DESCRIPTION	QTY
A		Back	1
B		Seat	1
C		Back metal	2
D		Leg	2
E		Wood cross	1
F		Metal cross	2

Hardware List

LABEL		DESCRIPTION	QTY
H1		Blots M6×14mm	6
H2		Blots M6×20mm	2
H3		Blots M6×35mm	6
H4		Blots M8×55mm	2
H5		Allen key M6	1

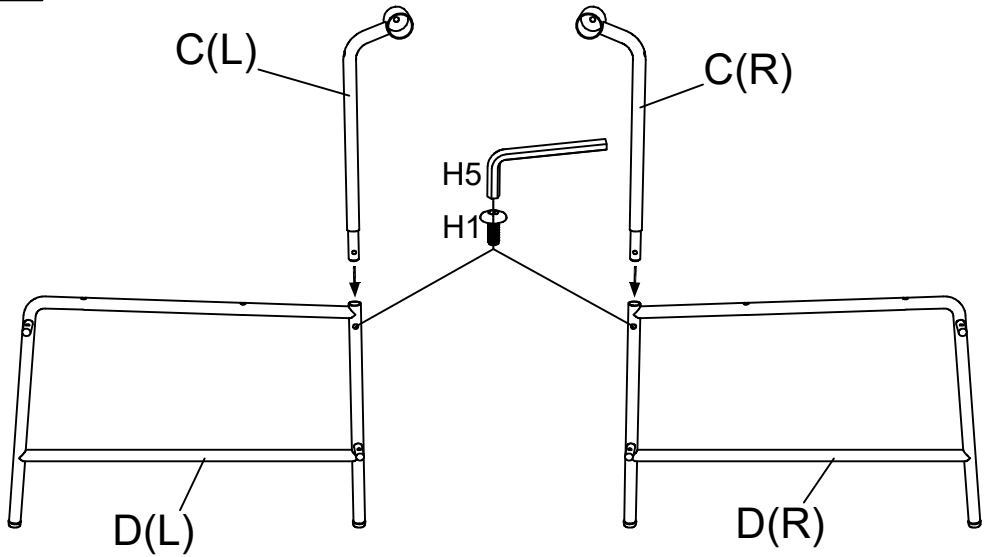
1

Tighten the bolts to 80% tightness.

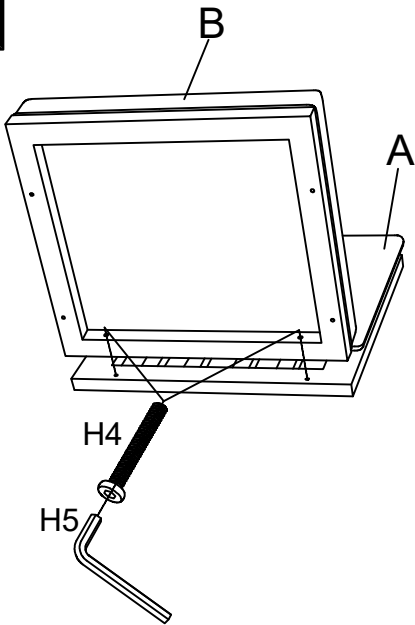
2

Tighten the bolts to 80% tightness.

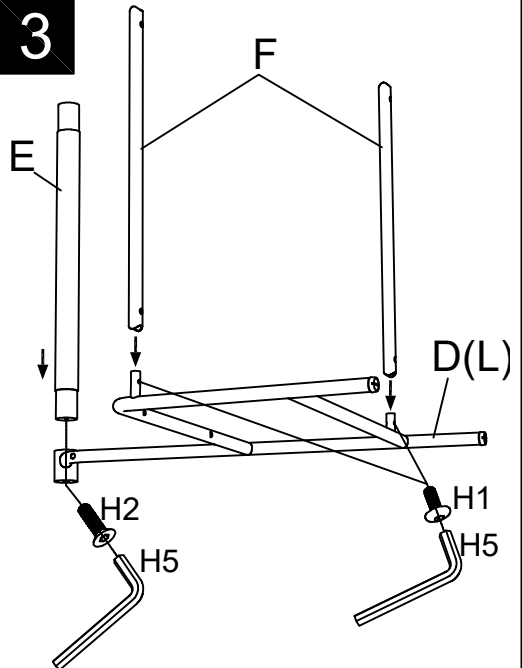
3

Tighten the bolts to 80% tightness.

4

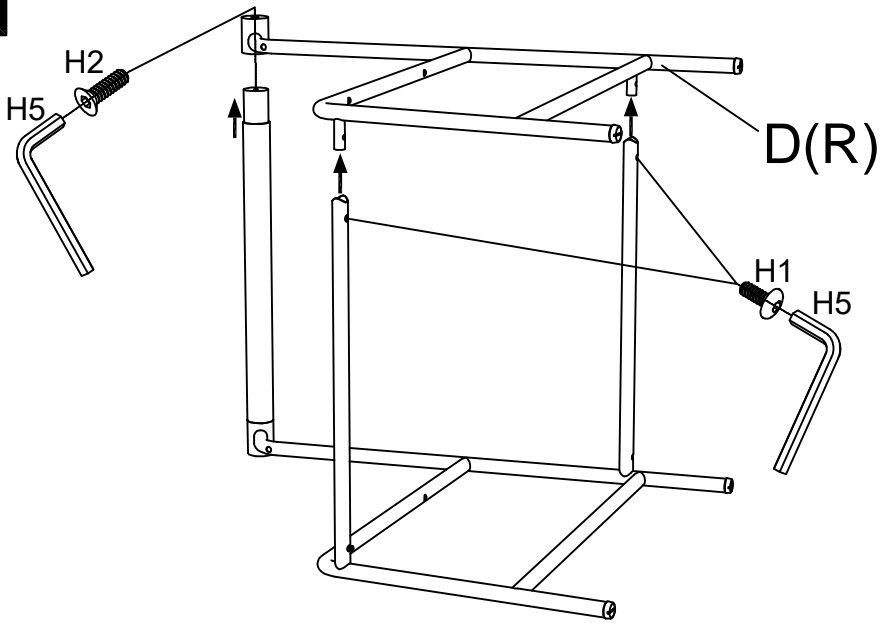

Tighten the bolts to 80% tightness.

5

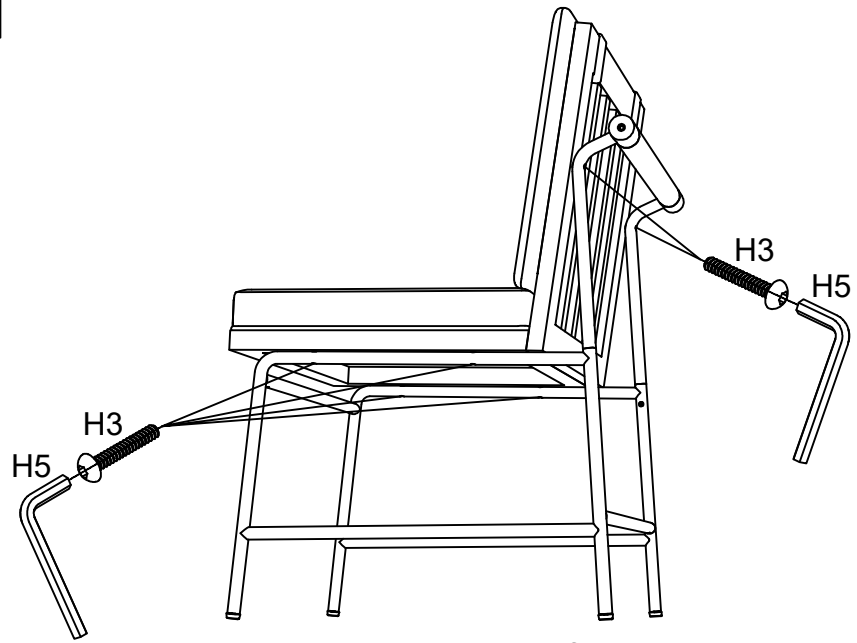

Adjust the chair so that it is leveled, then fully tighten all the bolts.