

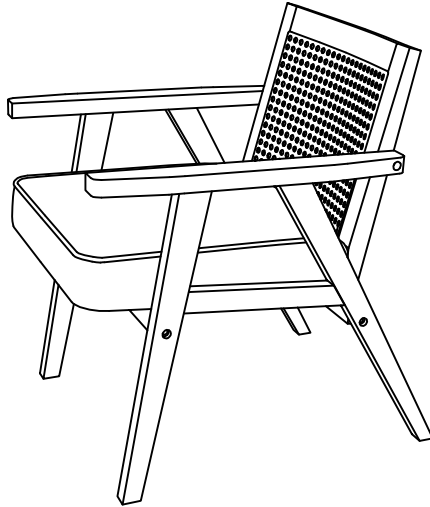

ASSEMBLY INSTRUCTION





Arm chair
TN-3513

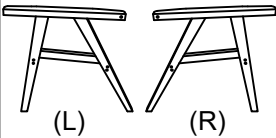
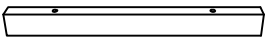
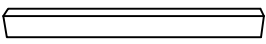

Component List

LABEL	DESCRIPTION	QTY
A	 Seat	1
B	 Back	1
C	 Arm (L) (R)	2
D	 Wood cross	1
E	 Wood cross	1

Hardware List

LABEL	DESCRIPTION	QTY
H1	 Dowel M10×40mm	4
H2	 Bolts M6×40mm	4
H3	 Bolts M6×60mm	4
H4	 Bolts M8×55mm	3
H5	 Spring washer M8	3
H6	 Flat washer M8×22×1.5mm	3
H7	 Allen key M6	1

1

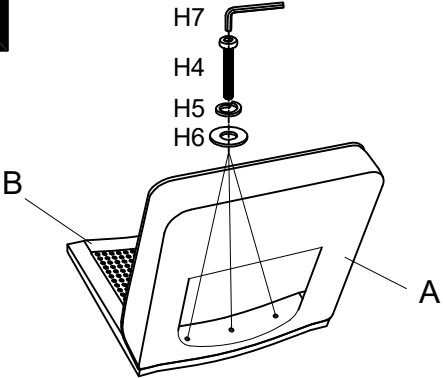

Tighten the bolts to 80% tightness.

2

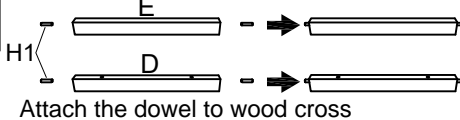

Attach the dowel to wood cross

3

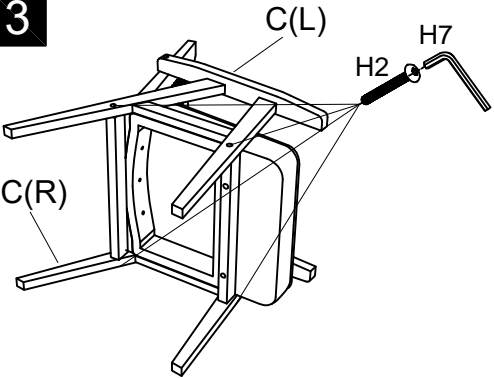

Tighten the bolts to 80% tightness.

4

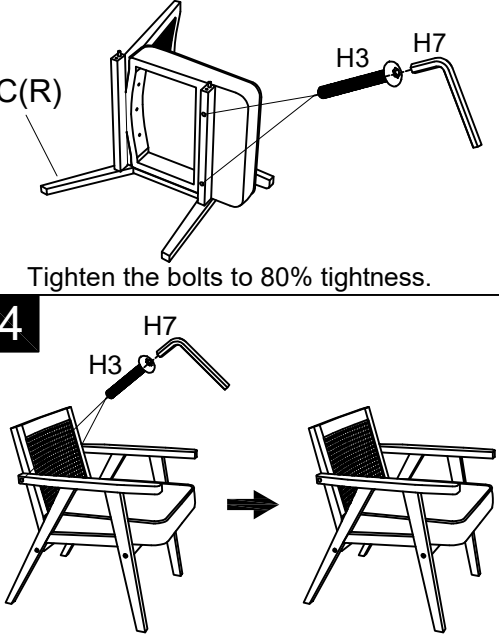

Adjust the chair so that it is leveled, then fully tighten all the bolts.