

## Single-phase Microinverter

# USER MANUAL

Model: GT400TL / GT600TL / GT800TL

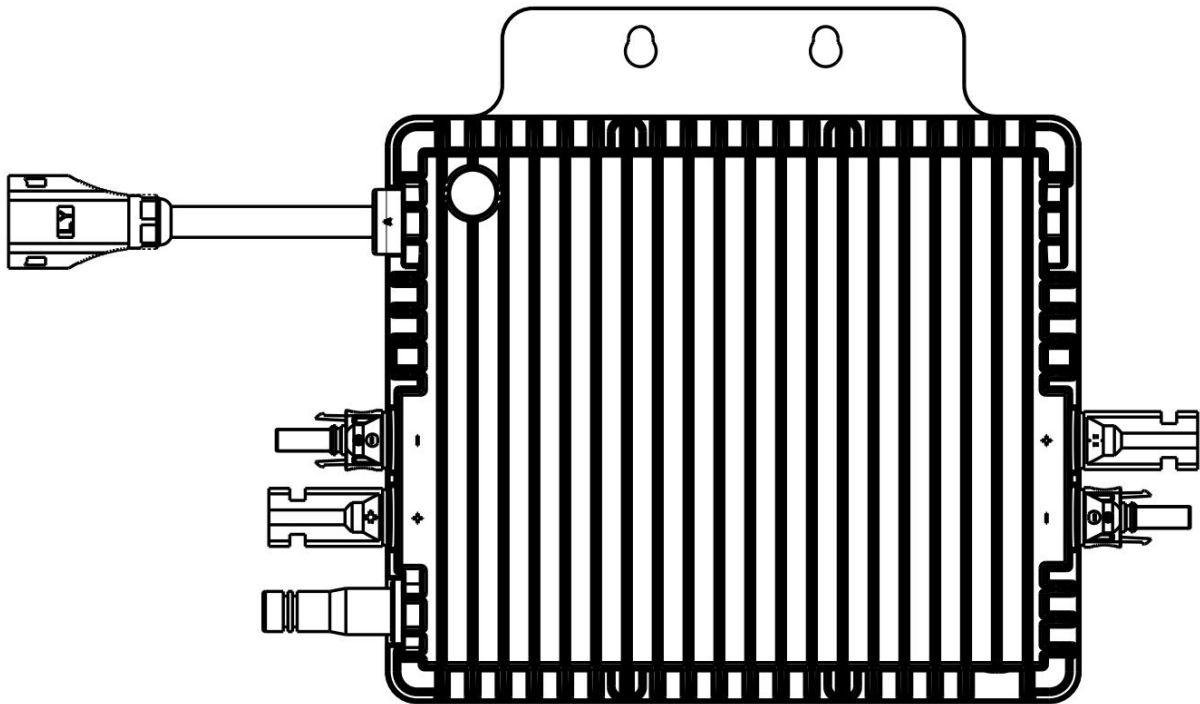

---

## About Microinverter

This system is composed of a group of microinverters that convert direct current (DC) into alternating current (AC) and feed the power to the public grid. The system is designed for 2-in-1 microinverters, i.e., one microinverter is connected with two PV modules.

Each microinverter works independently so as to guarantee the maximum power generation of each PV module. This setup is highly flexible and reliable as the system enables direct control of the production of each PV module.

## About the Manual

This manual contains important instructions for GT400TL/GT600TL/GT800TL microinverters and users shall read in its entirety before installing or commissioning the equipment. For safety reasons, only qualified technicians who have received training or demonstrate relevant skills can install and maintain this microinverter under the guidance of this document.

## Other Information

Product information is subject to change without notice. User manual will be updated regularly, so please refer to official website for the latest version.

---

---

# CONTENTS

<b>1. Important Notes</b>	<b>1</b>
1.1 Product Range	1
1.2 Target Group	1
1.3 Symbols Used	1
1.4 Radio Interference Statement	1
<b>2. About Safety</b>	<b>2</b>
2.1 Important Safety Instructions	2
2.2 Explanation of Symbols	3
<b>3. About Product</b>	<b>4</b>
3.1 About PV Microinverter System	4
3.2 About Microinverter	4
3.3 About 2-in-1 Unit	5
3.4 Highlights	5
3.5 Terminals Introduction	6
3.6 Dimensions (mm)	6
<b>4. Installation Preparation</b>	<b>7</b>
4.1 Position and Space Required	7
4.2 Connecting Multiple PV Modules to Microinverter	7
4.3 Installation Tools	8
4.4 AC Branch Circuit Capacity	8
4.5 Precautions	9
4.6 Unpacking Inspection	9
<b>5. Microinverter Installation</b>	<b>11</b>
5.1 Accessories	11
5.2 Installation Steps	11
<b>6. Troubleshooting</b>	<b>14</b>
6.1 Troubleshooting List	14
6.2 LED Indicator Status	15
6.3 On-site Inspection (For qualified installer only)	16
6.4 Routine Maintenance	16
<b>7. Decommission</b>	<b>17</b>
7.1 Decommission	17
7.2 Storage and Transportation	17
7.3 Disposal	17
<b>8. Technical Data</b>	<b>18</b>
<b>9. Registration on PC</b>	<b>19</b>
9.1 User Account Registration	19
9.2 Add Power Station	20
9.3 Add WiFi Dongle	21
<b>10. Registration on APP</b>	<b>22</b>
10.1 User Account Registration	22
10.2 Add Power Station	22
10.3 Add WiFi Dongle	23
<b>11. Networking Configuration</b>	<b>23</b>
11.1 Preparing work	23
11.2 Connect Network by APP	23
<b>12. LED Status Description</b>	<b>26</b>



# 1. Important Notes

## 1.1 Product Range

This manual describes the assembly, installation, commissioning, maintenance and troubleshooting of the following models of Microinverter:

- GT400TL
- GT600TL
- GT800TL



*\*Note: "400" means 400W, "600" means 600 W, "800" means 800 W.*

## 1.2 Target Group

This manual is only for qualified technicians. For safety purposes, only those who have been trained or demonstrate relevant skills can install and maintain this microinverter under the guidance of this document.

## 1.3 Symbols Used

The safety symbols in this user manual are shown as below.

Symbol	Description
	This indicates a hazardous situation that can result in deadly electric shocks, other serious physical injuries, or fire incidents.
	This indicates that directions must be strictly followed to avoid safety hazards including equipment damage and personal injury.
	This indicates that the act is forbidden. You should stop, use caution and fully understand the operations explained before proceeding.

## 1.4 Radio Interference Statement

This microinverter has been tested and complies with the requirements of CE EMC, meaning that it will not be affected by electromagnetic interference. Please note that incorrect installation may cause electromagnetic disturbances.

You can turn the equipment off and on to see if radio or television reception is interfered by this equipment. If this equipment does cause harmful interference to radio or television, please try the following measures to fix the interference:

- 1) Relocate other apparatus' antenna.
- 2) Move the microinverter farther away from the antenna.
- 3) Separate the microinverter and the antenna with metal/concrete materials or roof.
- 4) Contact your supplier or an experienced radio/ TV technician for help.

---







## 2. About Safety

### 2.1 Important Safety Instruction

The GT400TL/GT600TL/GT800TL microinverter is designed and tested according to international safety requirements. However, certain safety precautions must be taken when installing and operating this inverter. The installer must read and follow all instructions, cautions and warnings in this installation manual.

- All operations including transportation, installation, start-up and maintenance must be carried out by qualified, trained personnel.
- Check the product before installation to make sure there is no damage caused during transportation because such damage can compromise the insulation integrity and safety clearances. Choose installation location carefully and adhere to specified cooling requirements. Unauthorized removal of necessary protections, improper use, incorrect installation and operation may cause damage to the equipment or incur serious safety and shock hazards.
- You should get necessary approvals from local power operator before connecting the microinverter to the power grid. This connection must be made only by qualified technical personnel. It is the responsibility of the installer to provide external disconnect switches and Over Current Protection Devices (OCPD).
- Each input of the inverter is connected to one PV module. Do not connect batteries or other sources of power supply. The inverter can be used only if all the technical parameters are observed and applied.
- Do not install the equipment in flammable, explosive, corrosive, extremely hot/cold, and humid environment. Do not use the equipment when safety devices in these environments are not working.
- Personal protective equipment such as gloves and goggles must be used during installation.
- Inform the manufacturer about non-standard installation conditions.
- Do not use the equipment if any operating anomalies are found.
- All repairs must be done with qualified spare parts which must be installed in accordance with their intended use and by a licensed contractor or authorized service representative.
- Liabilities arising from components that are not produced by **our company** are on the part of their respective manufacturers.
- Whenever the inverter has been disconnected from the public grid, please be extremely careful as some components can retain charge sufficient to create a shock hazard. Before touching any part of the inverter, please ensure the surface and the whole equipment are within the limit of safe temperature and voltage potential.
- **Our company** is not liable for any damage caused by incorrect or improper operation.
- Electrical installation and maintenance shall be conducted by licensed electrician and shall comply with local wiring rules.

## 2.2 Explanation of Symbols

Symbol	Usage
	<p><b>Treatment</b></p> <p>To comply with European Directive 2002/96/EC on Waste Electrical and Electronic Equipment and its implementation as national law, electrical equipment that has reached the end of its life must be collected separately and returned to an approved recycling facility. Any device no longer needed must be returned to an authorized dealer or approved collection and recycling facility.</p>
	<p><b>Caution</b></p> <p>Do not come within 8 inches (20 cm) of the microinverter when it is in operation.</p>
	<p><b>Danger of high voltage</b></p> <p>High voltage in the microinverter can cause dangers to life.</p>
	<p><b>Beware of hot surface</b></p> <p>The inverter can become hot during operation. Avoid contact with metal surfaces during operation.</p>
	<p><b>CE mark</b></p> <p>The inverter complies with the Low Voltage Directive for the European Union.</p>
	<p><b>Caution</b></p> <p>Risk of electric shock, Energy storage timed discharge.</p>
	<p><b>Read manual first</b></p> <p>Please read the installation manual first before installation, operation and maintenance.</p>

### 3. About Product

#### 3.1 About PV Inverter System

A typical grid-tied PV inverter system includes PV modules, PV inverter, meter and power grid, as shown below. PV inverter converts the DC power generated by PV modules into AC power that meets the requirements of the power grid. The AC power is then fed into the grid via meter.

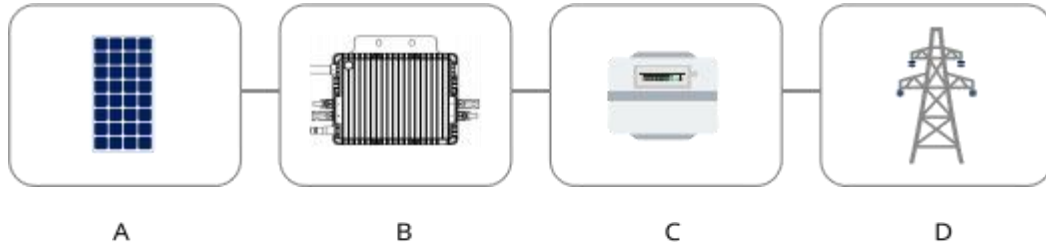

A	PV module
B	Microinverter
C	Grid-connected metering device
D	Power grid

#### 3.2 About Microinverter

PV Microinverter is a module-level solar inverter that tracks the maximum DC power point of each PV module, which is known as Maximum Power Point Tracking (MPPT).

This function of module-level MPPT means that when a PV module fails or is shaded, other modules will not be affected, boosting the overall power production of the system.

Microinverter can monitor the current, voltage and power of each module to realize module-level data monitoring.

Moreover, microinverter only carries a few dozen volts of DC voltage (less than 60 volts), which reduces safety hazards to the greatest extent.

The microinverters feature module-level monitoring. Microinverter data are collected by built-in WiFi module and sent to monitoring platform Cloud.

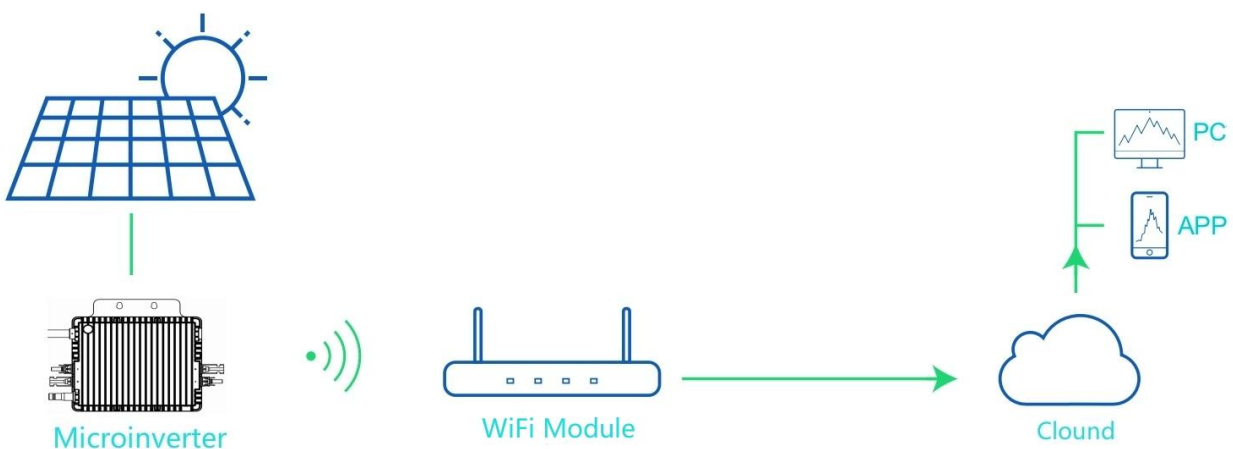



---

### 3.3 About 2 - in- 1 Unit

Microinverters can be divided into 1-in-1, 2-in-1 etc., depending on how many PV modules are connected to them. This means that the microinverter can connect to one module and two modules modules respectively, as shown below.

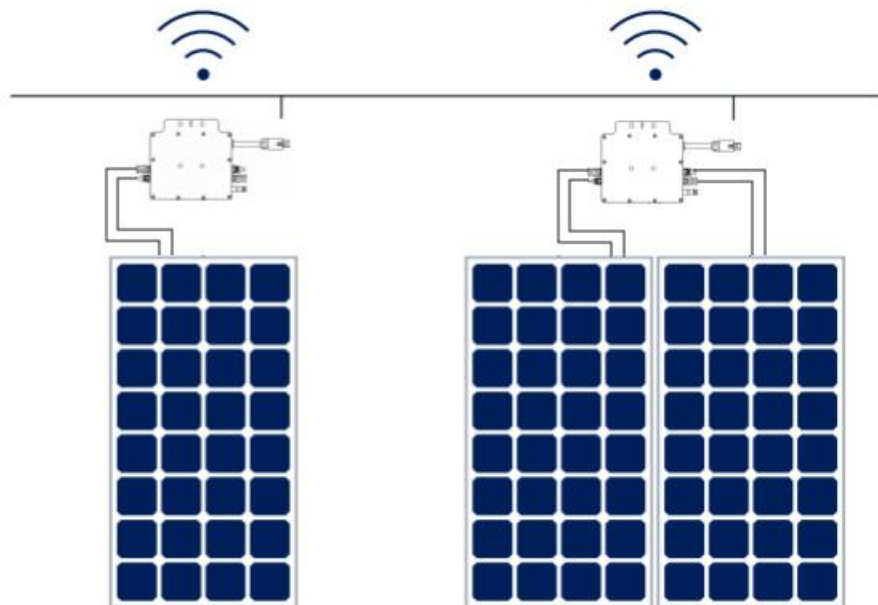

This manual is about 2-in-1 microinverter with the output power up to 800 VA.

Each microinverter connects to two PV modules at most with independent MPPT and monitoring, enabling greater energy harvest and easier maintenance.

### 3.4 Highlights

- Maximum output power up to 400/600/800 W
- Peak efficiency 94.2%
- Static MPPT efficiency 99.80%, Dynamic MPPT efficiency 99.76% in overcast weather
- Power factor: >0.99
- High reliability: IP67 (NEMA 6)

### 3.5 Terminals Introduction

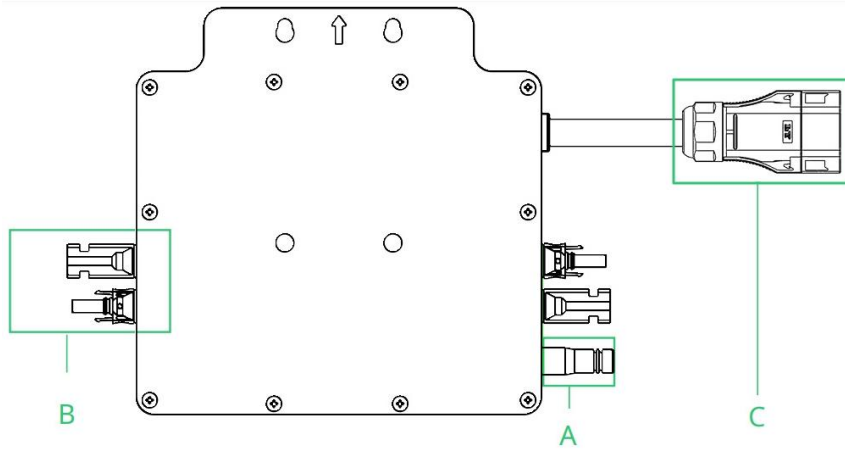

Object	Description
A	Antenna
B	DC Connector
C	AC Sub Connector

### 3.6 Dimensions (mm)

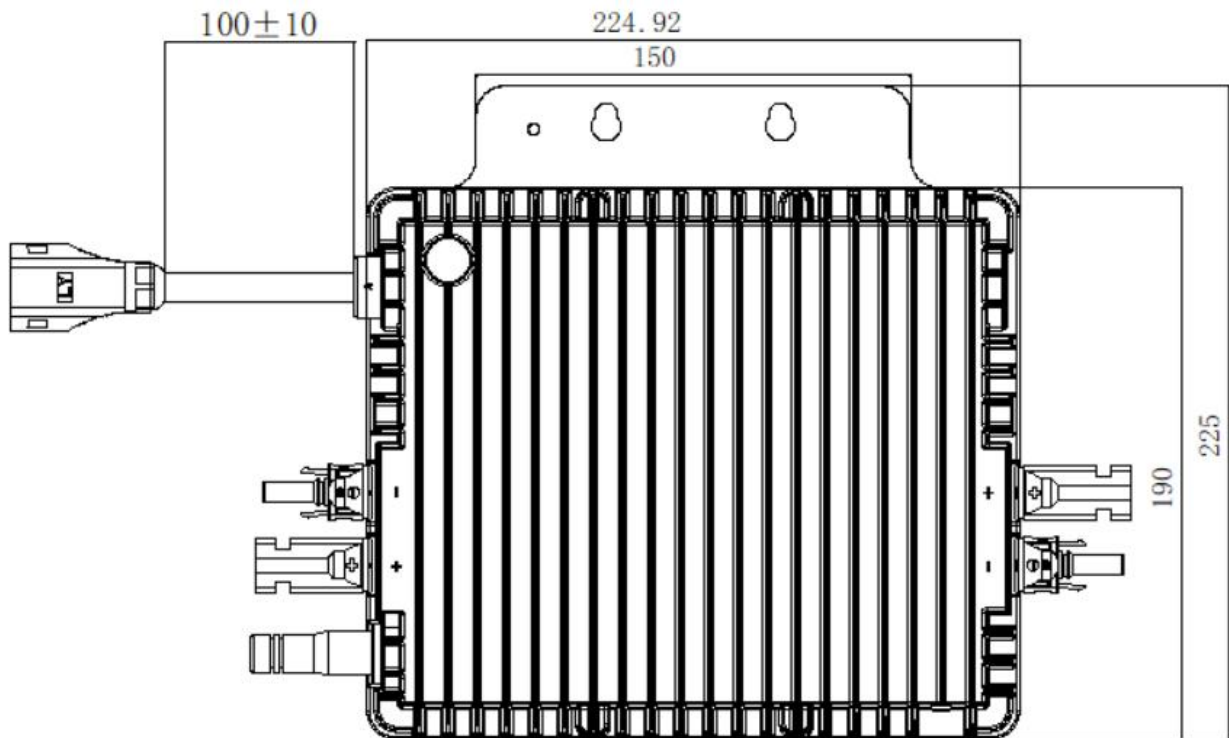

## 4. Installation Preparation

### 4.1 Position and Space Required

Please install the microinverter and all DC connections under the PV module or on the balcony wall to avoid direct sunlight, rain exposure, snow buildup, UV etc. The flat side of the microinverter should be up and facing the PV module or balcony wall.

Leave a minimum of 2 cm of space around the microinverter enclosure to ensure ventilation and heat dissipation.

### 4.2 Connecting Multiple PV Modules to Microinverter

General Guidelines:

1. PV modules should be connected to DC input ports of a microinverter.
2. Use DC extension cable when the original cable is not long enough. Please consult the local power operator to make sure that the DC cable complies with local regulations.

The typical wiring method is shown below

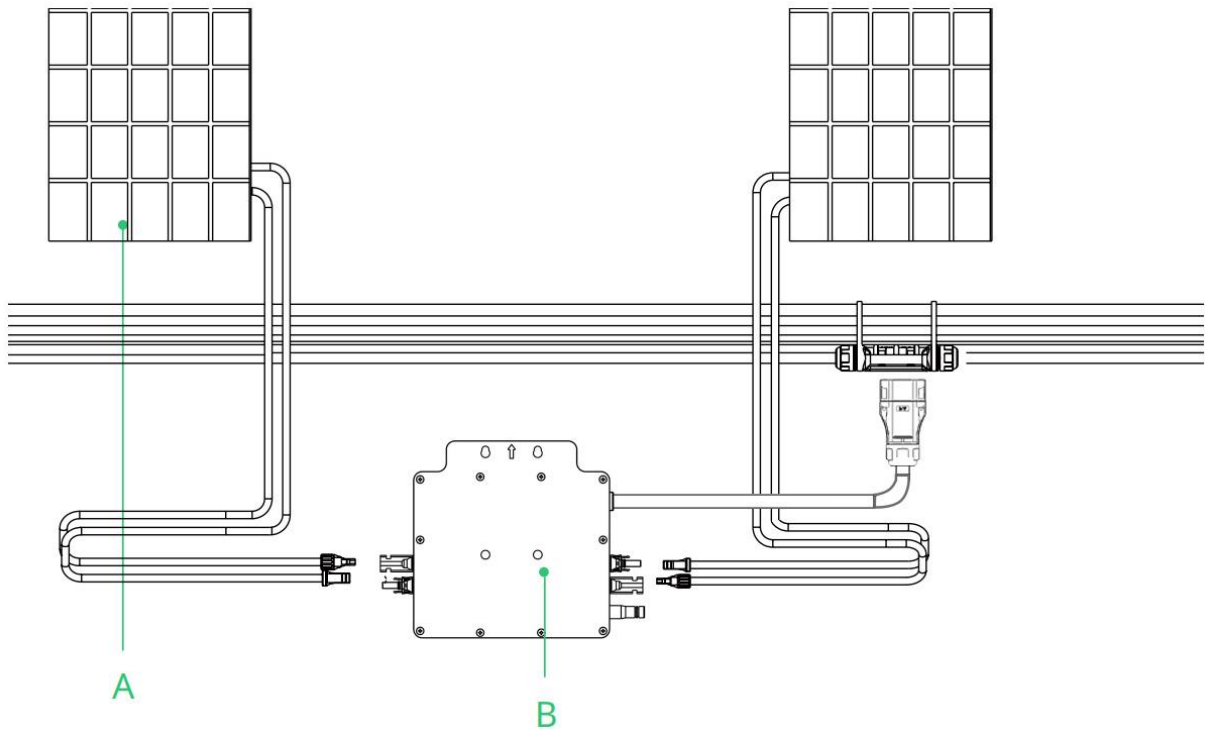

A	PV module
B	Microinverter

*Note:*

*The voltage of modules (considering the effect of local temperature) must not exceed the maximum input voltage of the microinverter. Otherwise, the microinverter may be damaged (refer to the Technical Data section to determine the absolute maximum input voltage).*

### 4.3 Installation Tools

Besides tools recommended below, other auxiliary tools can also be used on site.

Screwdriver	Multimeter
Socket Wrench or Allen wrench	Marker pen
Diagonal pliers	Steel tap
Wire cutters	Cable tie
Wire stripper	Torque and adjustable wrench
Utility knife	

Safety glove	Dust masks
Protective goggles	Safety shoes

### 4.4 AC Branch Circuit Capacity

GT400TL/GT600TL/GT800TL can be used with 12AWG AC Trunk Cable and the AC Trunk Connector. The number of micro-inverters on each 12AWG AC branch shall not exceed the limit as shown below.

	GT400TL	GT600TL	GT800TL	Maximum Over current Protection device (OCPD)
Maximum number Per 12 AWG branch	11	7	5	20A

*Note:*

*The number of microinverters that can be connected to each AC branch is determined by the ampacity (also known as current-carrying capacity) of the cable.*

## 4.5 Precautions

The equipment is installed based on the system design and the location of installation.

- The installation must be done with the equipment disconnected from the grid (power disconnect switch open) and with the PV modules shaded or isolated.
- Make sure the environmental conditions fit the microinverter's requirement (degree of protection, temperature, humidity, altitude, etc.) as specified in the Technical Data section.
- Avoid direct sunlight to prevent power derating which can be caused by an increase in the internal temperature of the microinverter.
- Keep the inverter in well-ventilated place to avoid overheating.
- Keep the inverter away from gases or flammable substances.
- Avoid electromagnetic interference because it can compromise the normal operation of electronic equipment.

Installation location shall meet the following conditions:

- Install only on structures specifically designed for PV modules (supplied by installation technicians).
- Install microinverter underneath PV modules or on the balcony wall to make sure it works in the shadow. Nonobservance may cause the derating of inverter production.

## 4.6 Unpacking inspection

Open the packaging and take out the product. Please check the accessories first. The packaging list is shown below.

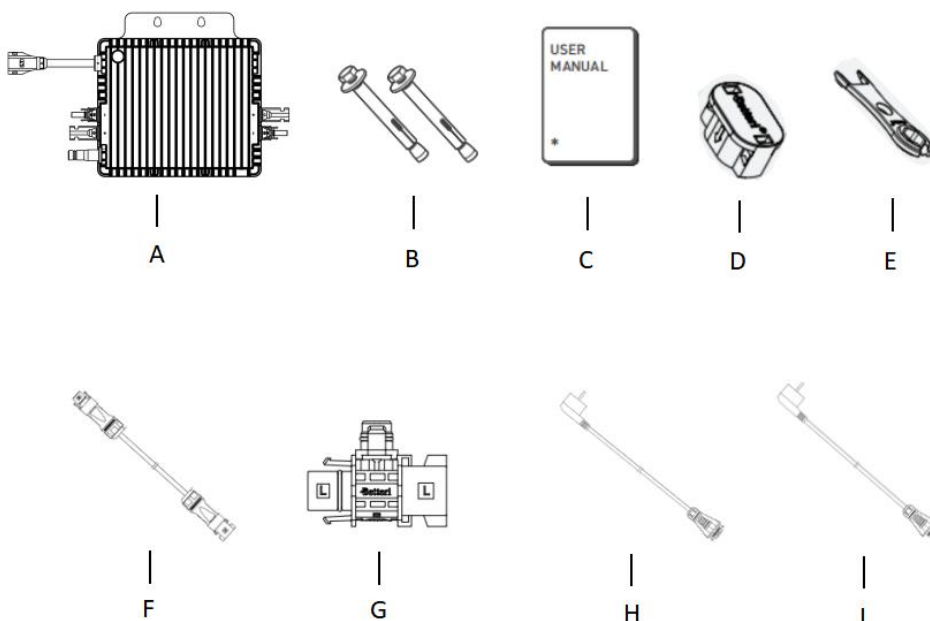

No.	Description	Remark
A	Microinverter	Include
B	M6X14 Expansion screw*2	Include
C	User Manual	Include
D	Protective plug	Optional
E	withdrawal tool	Optional
F	Microinverter Main Connection cable-800mm 2.5mm <sup>2</sup> (12AWG)	Optional
G	T-shaped Connector BC05C-T 300V/40A	Optional
H	BC05A+Euro/Korea general standard plug L-800mm 3*1.5mm <sup>2</sup>	Optional
I	BC05A+Euro/Korea general standard plug L-800mm 3*1.5mm <sup>2</sup>	Optional

## 5. Microinverter Installation

### 5.1 Accessories

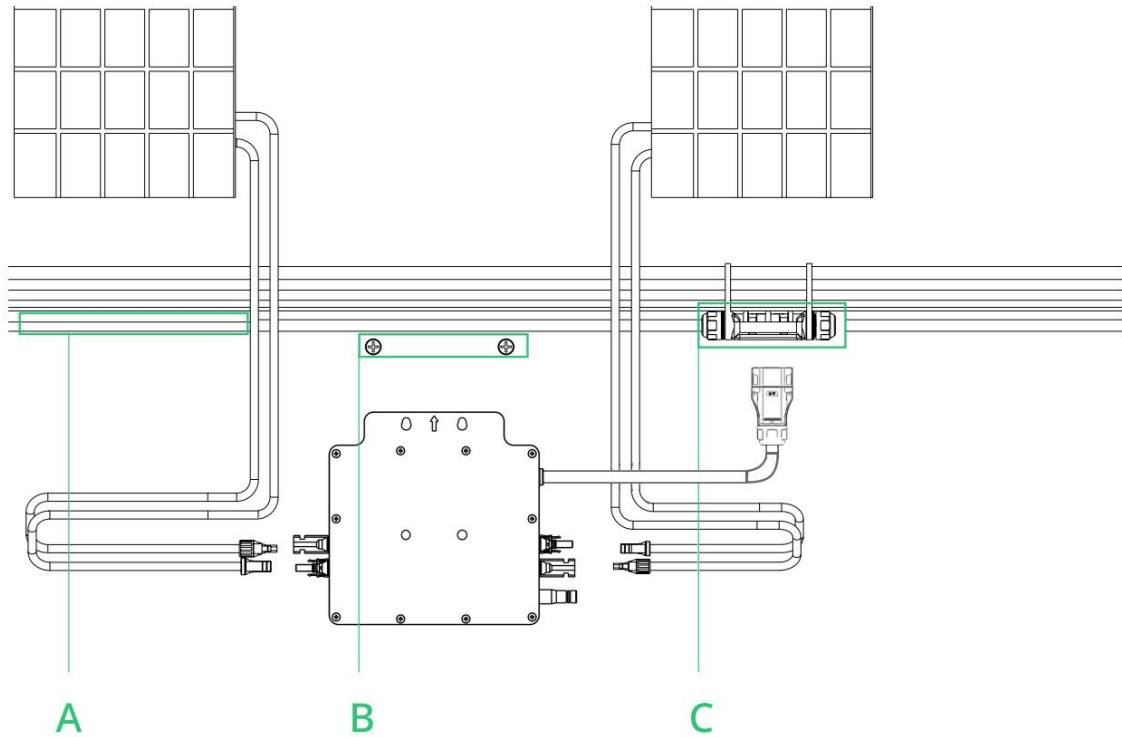

	Description
A	AC Trunk Cable, 12 AWG Cable
B	M6 × 10 screws (Prepared by the installer)
C	AC Trunk Connector

*\*Note: All accessories above are not included in the package and should be purchased separately.*

### 5.2 Installation Steps

The order of Step 1 and Step 2 can be reversed according to your planned needs.

#### Step 1. Plan and Install the Microinverter

- A ) Mark the position of each microinverter on the rail or balcony wall according to the PV module layout.
- B ) Fix the screws on the rail or balcony wall.
- C ) Hang the microinverter on the screws, and tighten the screws. The flat side of the microinverter should be facing the panel or balcony wall.

Note:

1. Microinverter installation and DC connections must be done to avoid direct sunlight, rain exposure, snow buildup, UV etc.
2. Leave a minimum of 2 cm of space around the microinverter enclosure to ensure ventilation and heat dissipation.
3. Mounting torque of the M6\*10 screw is 9 N·m. Do not over torque.
4. Do not pull or hold the AC cable with your hand. Hold the housing body instead.

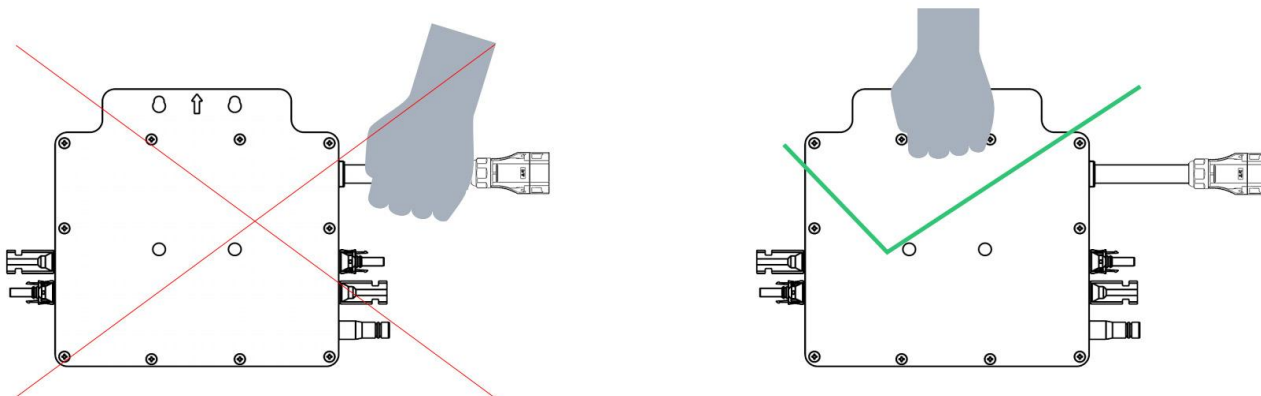

## Step 2. Plan and Build the AC Trunk Cable

AC Trunk Cable is used to connect the microinverter to the power distribution box.

- A) Select the appropriate AC Trunk Cable according to the spacing between microinverters. The connectors of the AC Trunk Cable should be spaced based on the spacing between microinverters to ensure that they can properly match.
- B) Determine how many microinverters you plan to install on each AC branch and prepare AC Trunk Connectors accordingly.
- C) Repeat the above steps to make all the AC Trunk Cables you need. Then lay out the cable on the rail or balcony wall as appropriate so that the microinverters can be connected to the Trunk connectors.

D) Attach the AC Trunk Cable to the mounting rail or balcony and fix the cable with tie wraps.

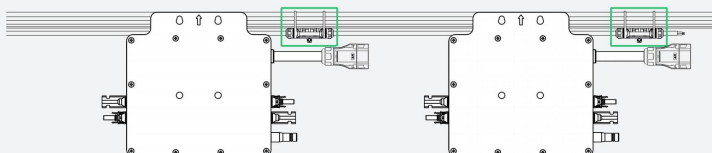



### Step 3. Complete the AC Connection

- A) Plug the AC Sub Connector of the microinverter into the AC Trunk Connector until you hear the click.

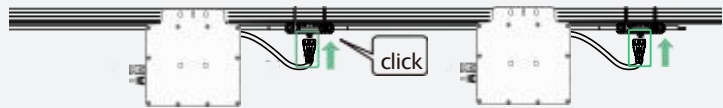

- B) Connect the AC end cable to the distribution box, and wire it to the local grid network.

- C) Please plug the AC Trunk Port Cap in any vacant AC Trunk Port to make it water- and dust-proof.

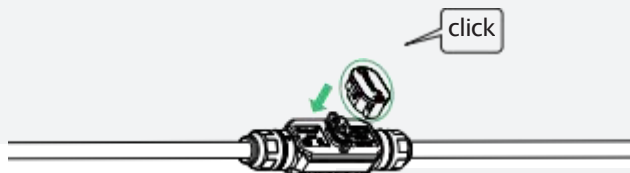

Note:

1. Make sure that the AC Trunk Connectors are kept away from any drainage channels.
2. In case you need to remove the microinverter AC cable from AC Trunk Connector, insert the AC Trunk Port Disconnect Tool into the side of AC Sub Connector to complete the removal.

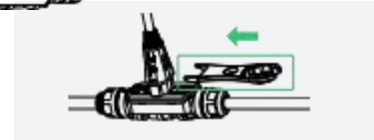

### Step 4. Connect PV Modules

- A) Mount the PV modules above the microinverter.
- B) Connect the PV modules' DC cables to the DC input side of the microinverter.

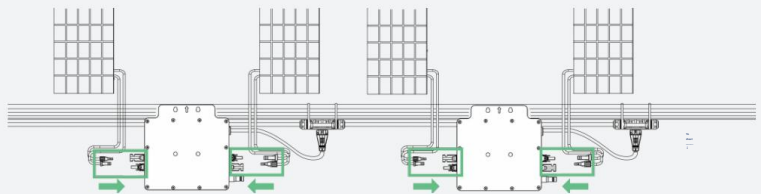

Note:

1. Make sure that the AC Trunk Connectors are kept away from any drainage channels.
2. In case you need to remove the microinverter AC cable from AC Trunk Connector, insert the AC Trunk Port Disconnect Tool into the side of AC Sub Connector to complete the removal.

### Step 5. Energize the System

- A) Turn on the AC breaker of the branch circuit.
- B) Turn on the main AC breaker of the house. Your system will start to generate power in about two minutes.

### Step 6. User Account Registration

Refer to the "User Manual", "Registration on PC", "Registration on APP" and "Network Configuration" to register the User Account and make Network Configuration.

## 6. Troubleshooting

### 6.1 Troubleshooting List

Alarm status	Handling suggestions
Over temperature protection	<ol style="list-style-type: none"> <li>1. Check the ventilation and ambient temperature at the microinverter installation location.</li> <li>2. If the ventilation is poor or the ambient temperature exceeds the limit, please improve the ventilation and heat dissipation.</li> <li>3. If the problem persists when ventilation and ambient temperature are appropriate, contact your dealer or technical support team.</li> </ol>
Offline	<ol style="list-style-type: none"> <li>1. Please make sure that the microinverter works normally (check if the DC voltage is within normal range and confirm the status of the LED indicator).</li> <li>2. Check if the SN on microinverter label is the same as on the monitoring platform.</li> <li>3. Check the communication status between the built-in WiFi module and monitoring system, and between the built-in WiFi module and the microinverter. If the communication is poor, try to make some improvements.</li> <li>4. If the alarm occurs frequently and cannot be recovered, contact your dealer or technical support team.</li> </ol>
Grid voltage fault	<ol style="list-style-type: none"> <li>1. If the alarm occurs occasionally, the grid voltage may be just abnormal temporarily. The microinverter can automatically recover after grid voltage becomes normal.</li> <li>2. If the alarm occurs frequently, check whether the grid voltage is within the acceptable range. If not, contact the local power operator or change the grid undervoltage or overvoltage protection limit in the grid profile via monitoring system with the consent of the local power operator.</li> <li>3. If the fault still exists, check the AC switch or AC wiring.</li> </ol>
Grid frequency fault	<ol style="list-style-type: none"> <li>1. If the alarm occurs occasionally, the grid frequency may be just abnormal temporarily. The microinverter can automatically recover after grid frequency becomes normal.</li> <li>2. If the alarm occurs frequently, check whether the grid frequency is within the acceptable range. If not, contact the local power operator or change the grid overfrequency protection limit via monitoring system with the consent of the local power operator.</li> </ol>
Power grid outage	Please check whether the AC switch, branch breaker and AC wiring is normal.
Grid disconnection	Please check whether the AC switch, branch breaker and AC wiring is normal.
Overload fault	<ol style="list-style-type: none"> <li>1. If the alarm occurs occasionally, the grid voltage may be just abnormal temporarily. The microinverter can automatically recover after grid voltage becomes normal.</li> <li>2. If the alarm occurs frequently, check whether the grid voltage is within the acceptable range. If not, contact the local power operator or change the grid undervoltage or overvoltage protection limit in the grid profile via monitoring system with the consent of the local power operator.</li> <li>3. If the fault still exists, check the AC switch or AC wiring.</li> </ol>
PV Input overvoltage	<ol style="list-style-type: none"> <li>1. Please make sure that the PV module open-circuit voltage is less than or equal to the maximum input voltage.</li> <li>2. If the PV module open-circuit voltage is within the normal range, contact your dealer or technical support team.</li> </ol>

## 6.2 LED Indicator Status

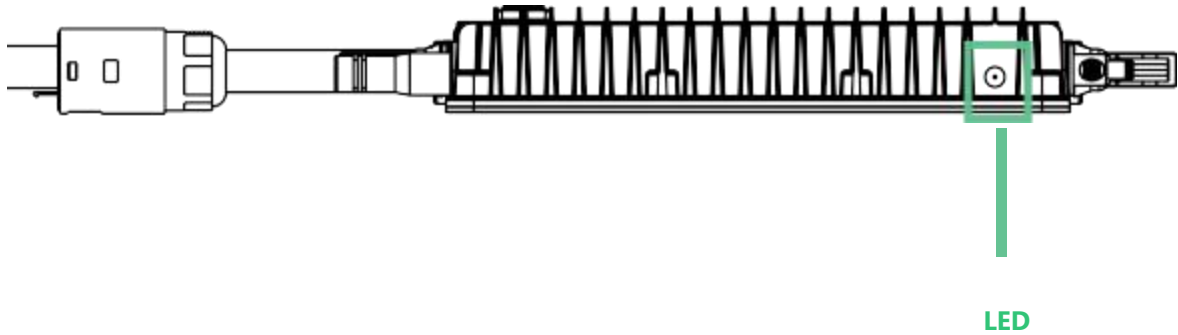

<b>(1) During Start-up</b>
<ul style="list-style-type: none"><li>• Green flash slowly</li></ul>
<b>(2) During operation</b>
<ul style="list-style-type: none"><li>• Solid green</li></ul>
<b>(3) Fault Status</b>
<ul style="list-style-type: none"><li>• Solid red</li></ul>
<b>(4) Networking</b>
<ul style="list-style-type: none"><li>• During networking: Red green alternating flash fast</li><li>• Allow APP to network: Red green alternating flash slowly</li><li>• Monitoring server is connected: Solid green</li></ul>

*\*Note:*

1. The microinverter is powered by DC side. If the LED light is not on, please check the DC side connection. If the connection and input voltage are normal, contact your dealer or technical support team.
2. The faults are reported to the monitoring system. Refer to the app or Monitoring Platform for more information.







### 6.3 On-site Inspection (For qualified installer only)

Troubleshoot a malfunctioning microinverter according to the following steps.

1	Check if the utility voltage and frequency are within the respective range shown in Technical Data section of this manual.
2	Check the connection to the utility grid. Disconnect the AC and the DC power. Please note that when the inverter is in operation, disconnect the AC power first to de-energize the inverter, and then disconnect the DC power. Never disconnect the DC wires while the microinverter is producing power.
3	Check the interconnection between all the microinverters on the AC branch circuit. Confirm that each inverter is energized by the utility grid as described in the previous step.
4	Make sure that every AC breaker is functioning properly and is closed.
5	Check the DC connection between the microinverter and the PV module.
6	Make sure that PV modules' DC voltage is within the allowable range shown in the Technical Data section of this manual.
7	If the problem persists, please call customer support.
	<u>Do not try to repair the microinverter by yourself. If the troubleshooting fails, please return it to the factory for replacement.</u>

### 6.4 Routine Maintenance

1. Only authorized personnel are allowed to carry out the maintenance operations and are responsible for reporting any anomalies.
2. Always use personal protective equipment provided by the employer during maintenance operation.
3. During normal operation, check the environmental conditions regularly to make sure that the conditions have not changed over time and that the equipment is not exposed to adverse weather conditions and has not been obstructed.
4. DO NOT use the equipment if any problems are detected. Restore its working conditions after the fault is fixed.
5. Conduct annual inspections on various components, and clean the equipment with a vacuum cleaner or special brushes.

	Do not attempt to dismantle or repair the microinverter! No user-serviceable parts inside for the safety and insulation reasons!
	The AC output wiring harness (AC drop cable on the microinverter) cannot be replaced. The equipment should be scrapped if the cord is damaged.
	Maintenance operations must be carried out with the equipment disconnected from the grid (power switch open) and the PV modules shaded or isolated, unless otherwise indicated.
	Never clean the equipment with rags made of filamentary or corrosive materials to avoid corrosion and electrostatic charges.
	Do not attempt to repair the product. All repairs should be done using only eligible spare parts.
	If all the microinverters are connected to the monitoring system, the monitoring system can limit the output power imbalance of all the microinverters between phases to below 3.68 kW if required.
	Each branch should have a circuit breaker. Central protection unit is unnecessary.

---

## 7. Decommission

### 7.1 Decommission

Disconnect the inverter from DC input and AC output, remove all connection cable from the microinverter, and remove the microinverter from the frame.

Please pack the microinverter in the original packaging. If the original packaging is no longer available, you can use a carton box that can hold 5 kg and can be fully closed.

### 7.2 Storage and Transportation

The packages are specially designed to protect components so as to facilitate transportation and subsequent handling. Transportation of the equipment, especially by road, must be done in a way that can protect the components (particularly the electronic components) from violent shocks, humidity, vibration, etc. Please dispose of the packaging elements in appropriate ways to avoid unforeseen injury.

Please examine the conditions of the components to be transported. Upon receiving the microinverter, you should check the container for any external damage and verify the receipt of all items. Please call the carrier immediately if there is any damage or if any parts are missing. In case of any damage caused to the inverter, contact the supplier or authorized distributor to request a repair/return and ask for instructions regarding the process.

The storage temperature range of microinverter is  $-40$  to  $85^{\circ}\text{C}$ .

### 7.3 Disposal

- If the equipment is not used immediately or is stored for a long period of time, make sure that it is properly packed. The equipment must be stored indoors with good ventilation and without any potential damage to the components of the equipment.
- Take a complete inspection when restarting the equipment after it has stopped operation for a long time.
- Please dispose of the microinverters properly in accordance with local regulations after they are scrapped because of potential harms to the environment.

## 8. Technical Data

 <b>WARNING</b>	Be sure to verify the following before installing Microinverter System.
---	---

1. Verify that the voltage and current specifications of the PV module match those of the microinverter.
  - The maximum open circuit voltage rating of the PV module must be within the operating voltage range of the microinverter.
  - We recommend that the maximum current rating at MPP should be equal to or less than the maximum input DC current.
2. The output DC power of PV module shall not exceed 1.35 times of the output AC power of the microinverter.

GT400TL/GT600TL/GT800TL   Specifications			
Model	GT400TL	GT600TL	GT800TL
<b>PV Input (DC)</b>			
PV Max Input Power (W)	250 x2	350 x2	450 x2
PV Max Input Voltage (V)	60	60	60
Start-up Voltage (V)	30	30	30
Full Load MPPT Voltage Range (V)	33 ~ 55	33 ~ 55	33 ~ 55
Operating Voltage Range (V)	16~60	16~60	16~60
Max Input Current (A)	7A x2	12A x2	14A x2
Maximum input short-circuit current (A)	15A x2	20A x2	25A x2
Number of MPP Trackers	2	2	2
<b>AC Output</b>			
Rated Output Power (W)	400	600	800
Nominal Output Current (A)	1.7	2.6	3.48
Nominal Grid Voltage (V)	230 (single-phase)	230 (single-phase)	230 (single-phase)
Grid Voltage Range (V)	180 ~ 264VAC	180 ~ 264VAC	194 ~ 264VAC
Nominal Grid Frequency (Hz)	50Hz / 60Hz	50Hz / 60Hz	50Hz / 60Hz
Max. Total Harmonic Distortion	<3%(rated power)	<3%(rated power)	<3%(rated power)
Power Factor	>0.99	>0.99	>0.99
Max Parallel	8pcs	8pcs	6pcs
Anti-islanding Protection	Yes	Yes	Yes
AC Short Circuit Protection	Yes	Yes	Yes
<b>System</b>			
Max. Efficiency	94.2%	94.2%	94.2%
Protection Class	CLASS I	CLASS I	CLASS I
Protection Level	IP67	IP67	IP67
Cooling Method	Natural Cooling	Natural Cooling	Natural Cooling
Monitoring	WIFI	WIFI	WIFI
Operating Temperature Range (°C)	-40 ~ +65	-40 ~ +65	-40 ~ +65
Manufacturer's Warranty	10 Years	10 Years	10 Years
<b>Mechanical Data</b>			
Dimensions (W × H × Dmm)	225 x 225 x 37	225 x 225 x 37	225 x 225 x 37
Weight (kg)	3.25	3.25	3.25
<b>Product Certification</b>			
Test standards	IEC 62321-3-1:2013; IEC 62321-4:2013+A1:2017; IEC 62321-5:2013 IEC 62321-6:2015; IEC 62321-7-1:2015; IEC 62321-7-2:2017 IEC 62321-8:2017  ENIEC 61000-6-3:2021; ENIEC 61000-6-1:2019 ENIEC 61000-3-2:2019+A1:2021; EN 61000-3-3:2013+A2:2021  EN 62109-1:2010; EN 62109-2:2011 VDE-AR-N 4105:2018; conjunction with DIN VDE V 0124- 100:2020		

3.

\*1 Nominal voltage/frequency range can vary depending on local requirements.

\*2 Refer to local requirements for exact number of microinverters per branch

## 9. Registration on PC

### 9.1 User Account Registration

(1) Enter the website <https://www.mini-ems.com>.

A user registration form with a blue background. It features two input fields: "Account" with a person icon and "Password" with a lock icon and a dropdown arrow. Below the fields are two buttons: "Log in" (blue) and "Register" (green). At the bottom, there is a checkbox labeled "Remember the password" and a link labeled "Sample power station" in blue text.

(2) Click on "Register" to start registering user account.

An identical user registration form to the one above, but with a red arrow pointing to the "Register" button.

(3) Fill in the corresponding information according to the prompts and click on "Register" .

## Register

\* User Name : It can be changed later.

\* Login Account : Use 1 to 20 letters or numbers or a mix of them. It can not be changed afterwards.

\* Verification Code : Contact your seller to get it.

\* Login Password : Use 6 to 20 characters with a mix of letters and numbers.

\* Password Again : Use 6 to 20 characters with a mix of letters and numbers.

E-mail :

Cell Number :

\* Country : Country

Complete Address :

Register

Close

## 9.2 Add Power Station

(1) Fill in the registered account and password, and log in to the system.

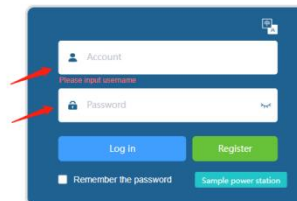

(2) Click on the "Power station configuration" of "Site management" , then click on "Add power station"

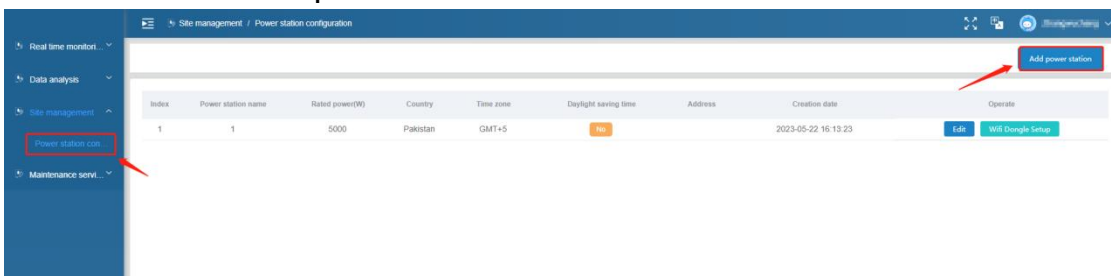

(3) Fill in the corresponding information according to the prompts and click on "Add" .



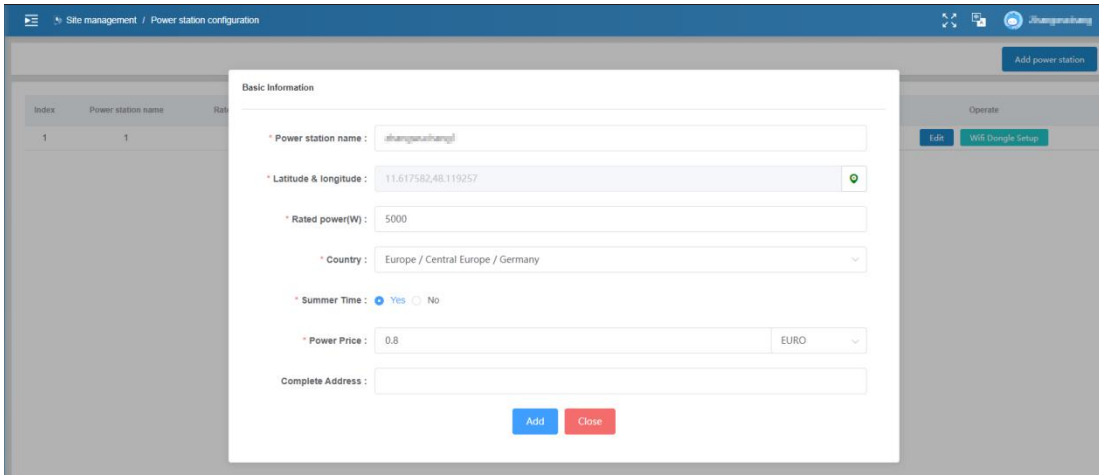

### 9.3 Add WiFi Dongle

(1) Select the power station at "Power station configuration", then click on "Wifi Dongle Setup"

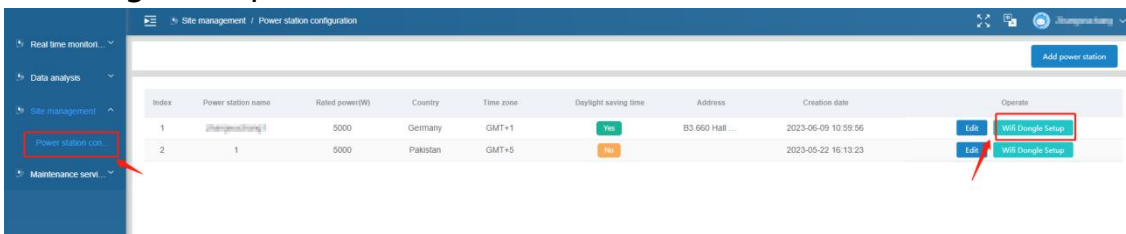

(2) Click on "Add Wifi Dongle"

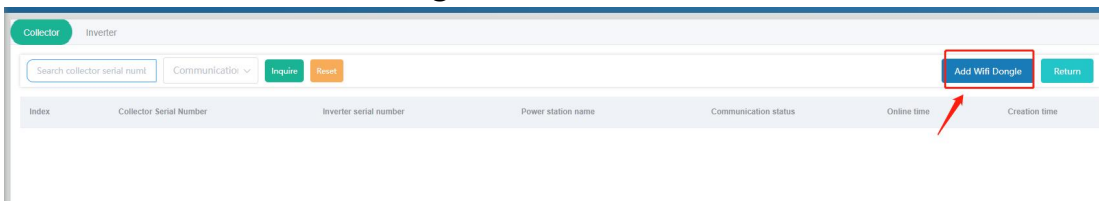

(3) Fill in according to the serial number and verification code on the back of Microinverter, and then click on "Add".

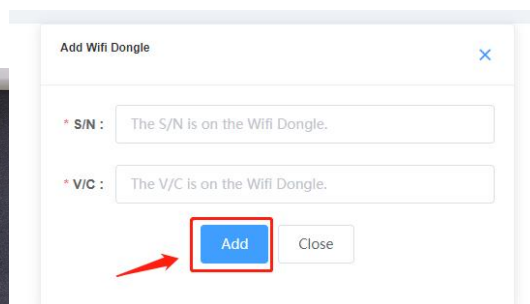

(4) WiFi Dongle adding completed

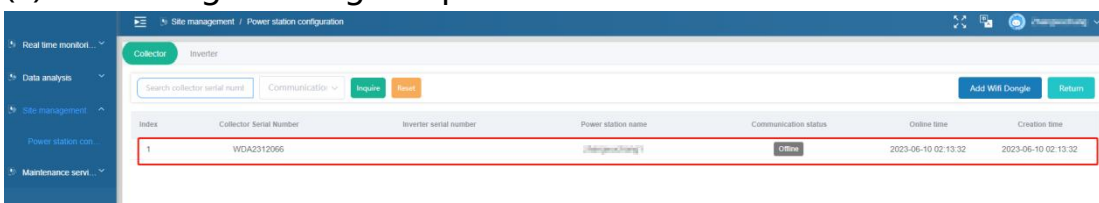

# 10.Registration on APP

## 10.1 User Account Registration

- (1) Enter APP, and click on "Register" to start registering user account.
- (2) Fill in the corresponding information according to the prompts.
- (3) Click on "Register" .

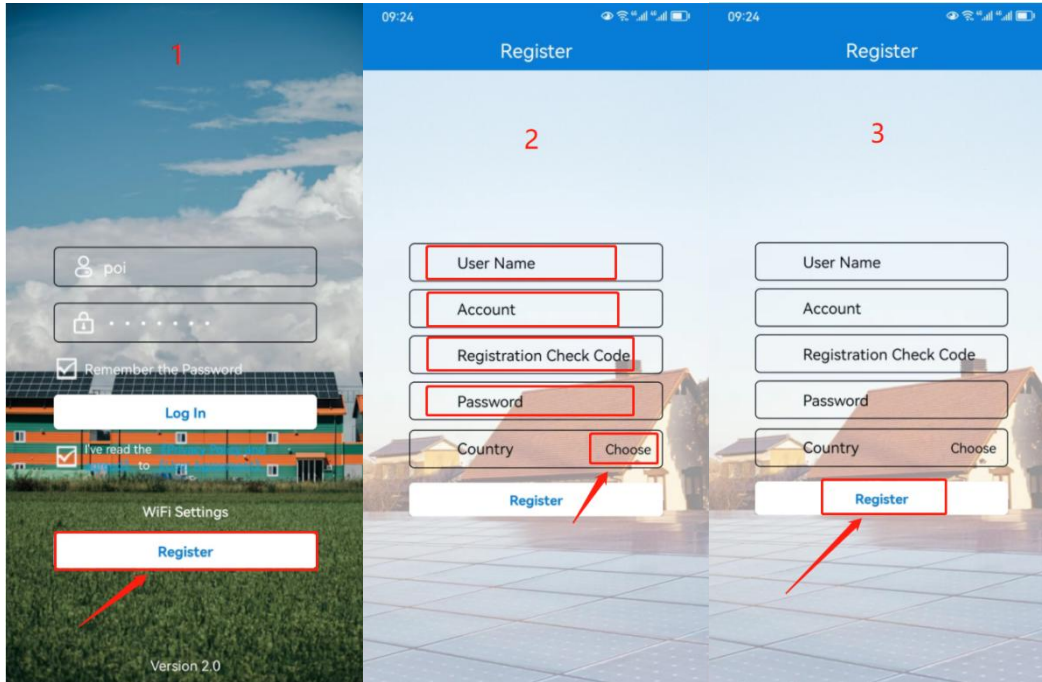

## 10.2 Add Power Station

- (1) Fill in the registered account and password on APP, and log in to the system.
- (2) Click on "Add Plants" and Fill in the corresponding information
- (3) Click on "Add"

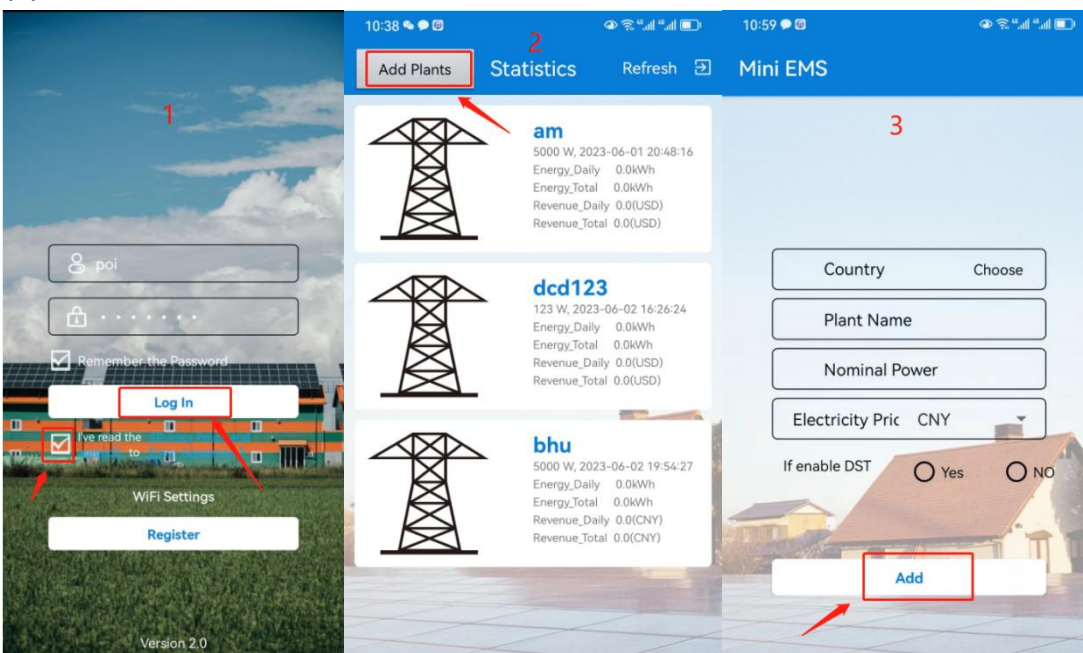

## 10.3 Add WiFi Dongle

- (1) Click on the corresponding plant of plant list to enter.
- (2) Click on "Collector" and fill in according to the serial number and verification code on the back of Microinverter.
- (3) Click on "Add" to complete WiFi Dongle adding.

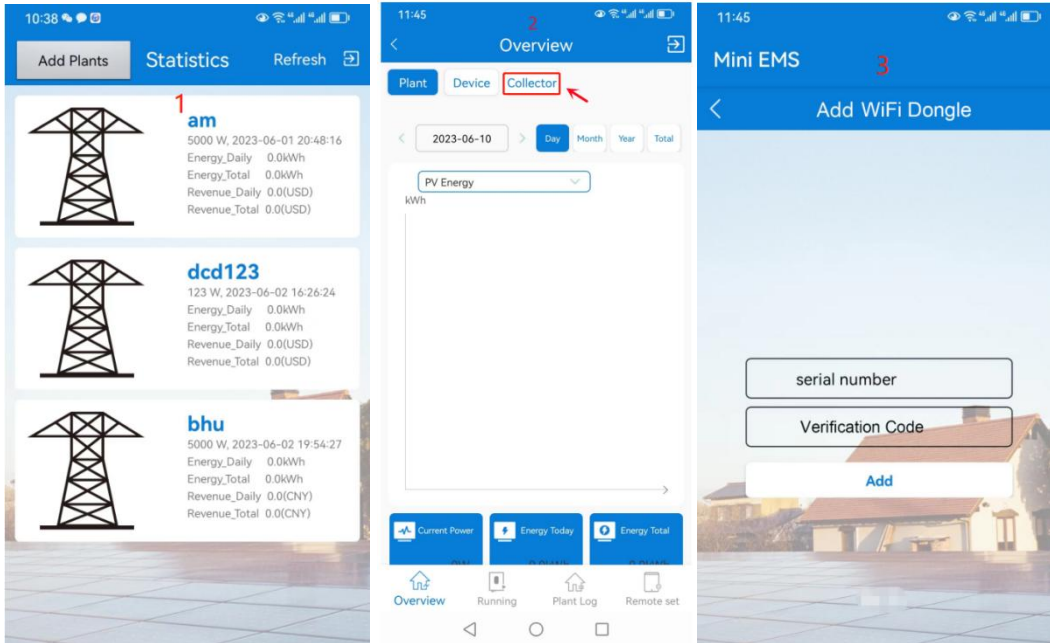

## 11. Network Configuration

### 11.1 Preparing work

- (1) Turn on the Inverter
- (2) Turn on the Router

### 11.2 Connect Network by APP

- (1) Download the Mini EMS app in the Google app, or scan the QR code in the following image to download the corresponding app.



(2) Connect the phone to 2.4G WiFi and place the inverter within this WiFi coverage range.

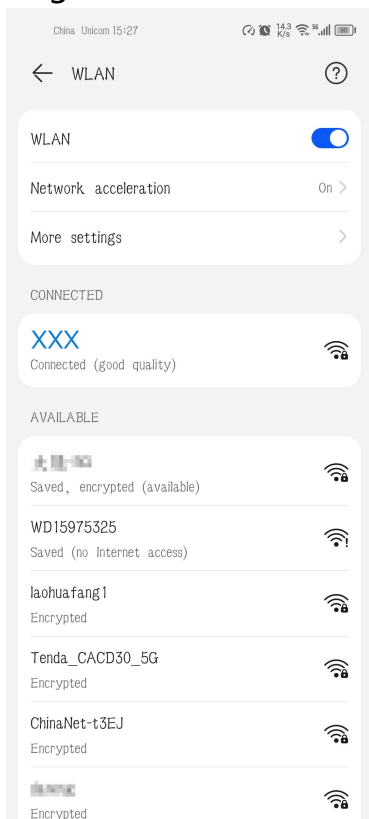

(3) Open the Mini EMS app, click on the "WiFi Settings" option, agree to authorize the app's location permissions, and enter the WiFi password.

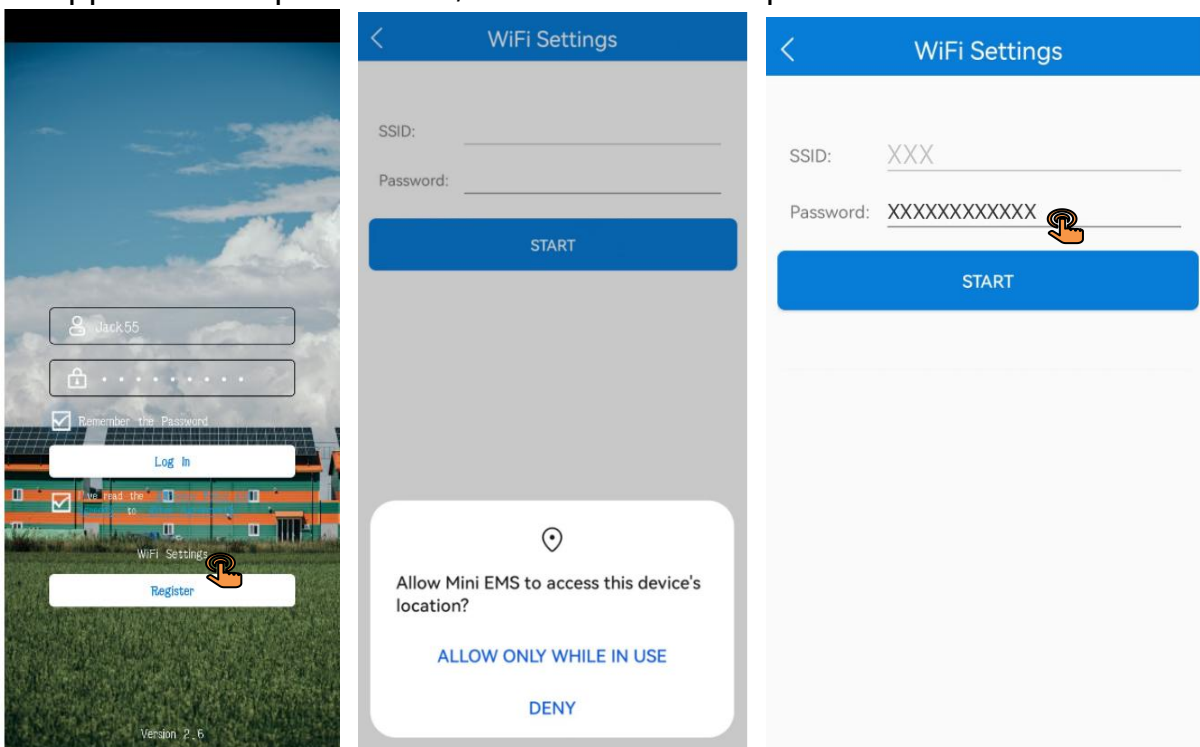

(4) Click "Start" on the app while waiting for the LED light of microinverter to slowly flash red and green alternately; When the app interface displays the content: SmartLink completed, it indicates that the network pairing is completed. Then wait for the LED green light to solid on, indicating that the microinverter networking is successful.

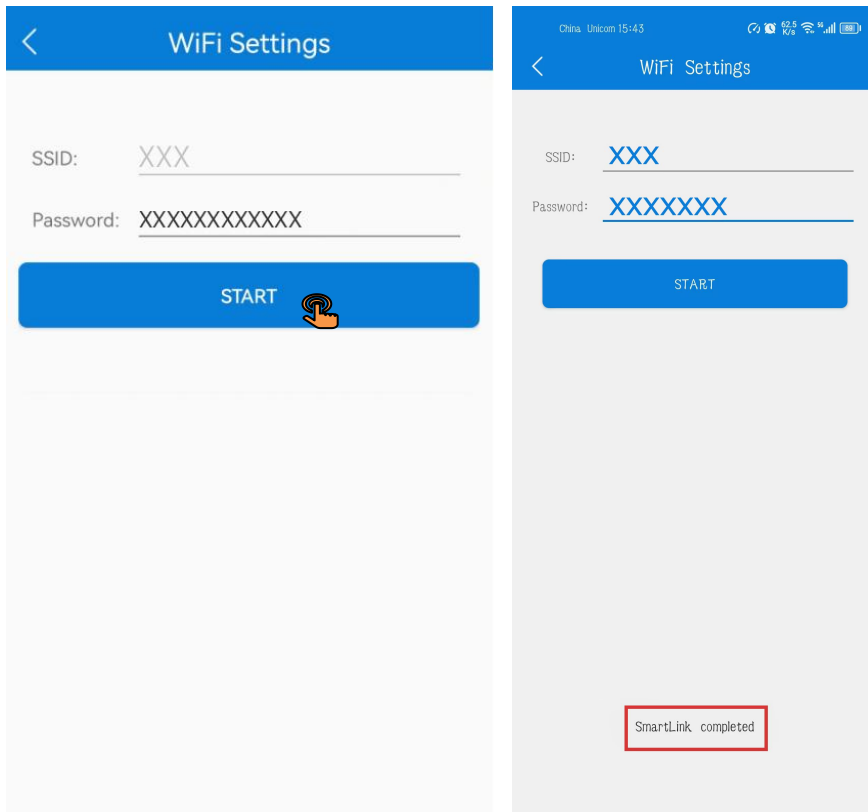

Note: The prompt information of IOS APP is slightly different.

---

## 12.LED Status Description

Status description	LED Status
Networking	Red green alternating flash fast
Allow APP to network	Red green alternating flash slowly
Monitoring server is connected	Solid green

## 13.Frequently Asked

(1) WiFi Dongle can't connect to the network

- a) Move the wireless router closer to the inverter, or use a wireless signal booster.
- b) WiFi Dongle only supports connecting to the 2.4GHz frequency network.
- c) The wireless name of the router should be composed of English and numbers.
- d) The Router prohibits the use of dual-band integration function.
- e) When using the APP to configure the network, the network configuration only can be allowed when the two indicators flash slowly.

(2) When using the APP to configure the network for the built-in WiFi Dongle, the network currently connected to the mobile phone cannot be retrieved.

- a) Exit the WIFI setting interface and enter again.
- b) Check if the network currently connected to the phone is at 2.4GHz frequency.

(3) Unable to find the " WXXXXXXXXX " serial number ( Please check the label on the back of the inverter for the serial number )

- a) Please make sure that the inverter is powered on and the little collector expert is plugged in.
- b) If the microinverter has been reset, then it will be automatically renamed "WXXXXXXXX" later.

(4) After the configuration is completed, the green lights are solid on, but the status on the PC monitoring system is still displayed as offline.

- a) Wait five minutes before checking the PC monitoring system data.

- 
- b) Check again whether the serial number of the registered WiFi Dongle is consistent with the current serial number of microinverter.
  - C) Restart the microinverter.