

# iHoverboard

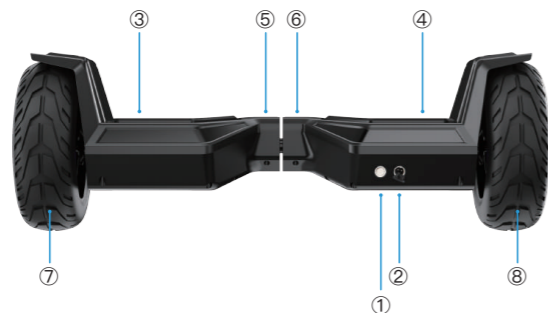

on/off  
①



charging  
②



The pedal  
③ ④



Running Indicator  
⑤



Power lamp  
⑥



The motormp  
⑦ ⑧



10°



8~12 km/h



# iHoverboard

## iHoverboard H8



# Contents

UK

What's included .....	01
Product overview diagram .....	02
Safety instructions .....	03
Riding method .....	05
Safety riding instructions .....	09
Battery charging and care .....	12
Contact us .....	15



## What's included

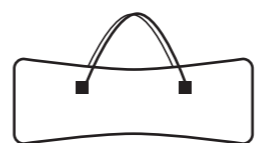
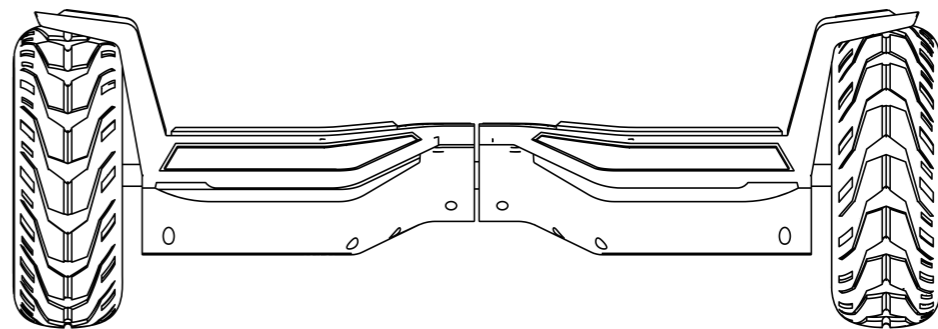

Carry Bag

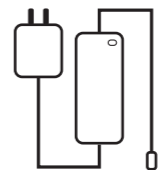

Charger

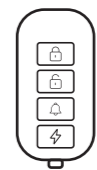

Remote Control



Manual



## Product Overview Diagram

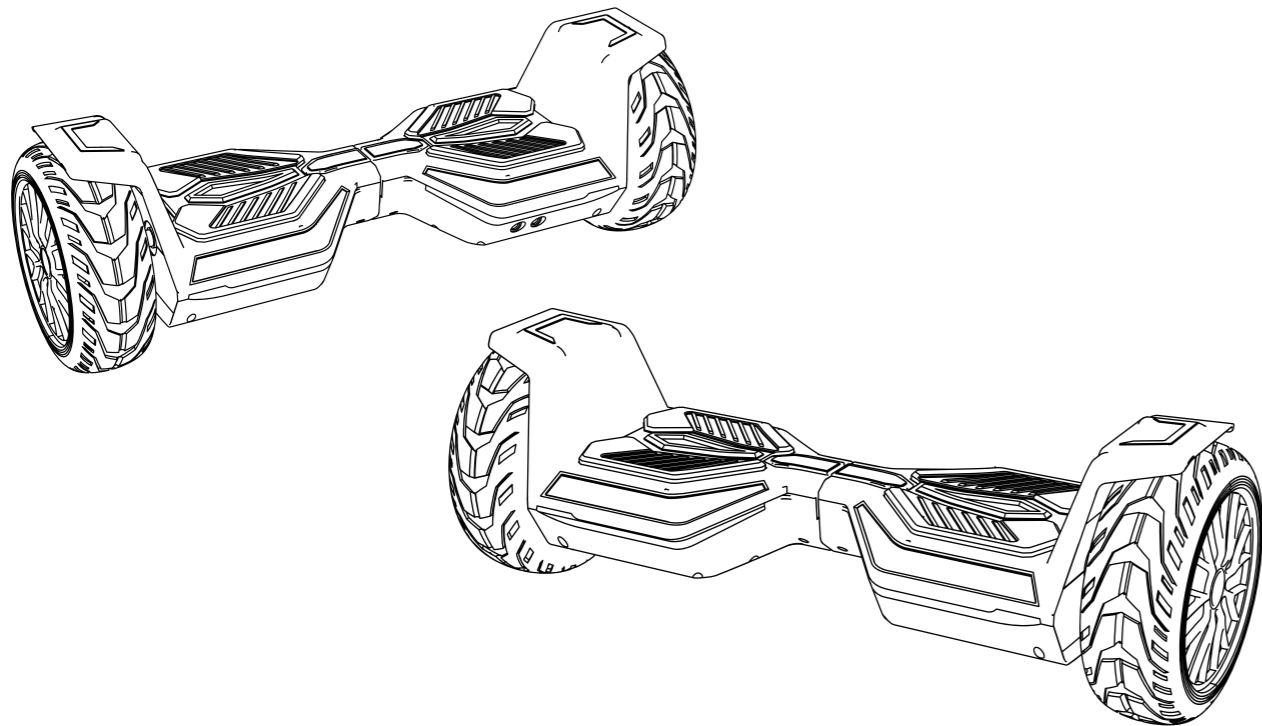

## Safety Instructions

### ● About the safe use of self-balancing scooters

Our company hopes that all riders can ride safely and enjoy the fun of self-balancing scooters; just like learning to ride a bicycle, drive a car or use other means of transportation, all these experiences can be applied to our products, giving you better use of the self balancing scooter.

- Following the relevant instructions will allow you to ride safely, and we strongly recommend reading the "Operating Instruction Manual" when you ride the self-balancing scooter for the first time. Please check the tires for damage before each ride. If there is any loose part, please contact the dealer for repair.
- Please read the instruction manual and you can get a lot of important safety information, including speed limit, warning indicator, safe shutdown.
- Please do not make any riding action that endangers personal or property safety.
- Do not modify the parts at will. Modification by yourself will not only affect the appearance of the self-balancing scooter, but may even destroy its performance and cause serious injury.

### ● Rider Weight Limit

- There are two reasons for rider's weight limit: 1. To ensure rider safety; 2. To avoid damage to the self-balancing scooter caused by overloading.
- Maximum weight limit: 100kg.
- Minimum weight limit: 20kg.

**▲WARNING!** There is a risk of falling when the hoverboard is overloaded.

## ● Range

The range of a self-balancing scooter is related to many factors, such as:

- Terrain: Riding on smooth ground will increase the range, otherwise the range decreases.
- Weight: The weight of the rider affects the range.
- Ambient temperature: Storage at the recommended temperature will increase the range, on the contrary, it will reduce the range at extreme temperatures.
- Maintenance: Proper charging and maintenance of the battery can increase the range, otherwise it will shorten the range.
- Speed and riding way: Maintaining a medium speed can increase the range. And frequent starting, stopping, acceleration, and deceleration will shorten the range.

## ● Speed limit

- The top speed is 8-12 kilometers per hour.
- When the hoverboard is faster than the top speed, the buzzer will give an alarm.
- Riding below the speed limit helps to maintain balance; when the speed is greater than the speed limit, the hoverboard will raise its head upwards. Please keep the speed to a safe speed.



## Riding method

When using a self-balancing scooter, you must pay attention to relevant safety matters, so you must fully understand all the precautions in the instruction manual before riding. It is very important for you to understand these safety issues before use.

## ● Riding steps

- Step 1. Press the power switch to turn on the power, the working indicator will light and the self-balancing scooter will enter automatic balance state.
- Step 2. Step on the deck with a trigger switch with one foot. After keeping your body stable, step the other foot on the other deck of the self-balancing scooter.
- Step 3. After successfully balancing the center of gravity, you can control the self-balancing scooter. At this time, the self-balancing scooter will remain static, and you can slightly tilt forward or backward your body to control the forward or backward movement of the self-balancing scooter. Avoid excessive your body movement.

**NOTE :** If the body of the self-balancing scooter is not in a level state when off the ground, there will be beep alarms and the indicator will also light. At this time, the system will prohibit entering into the automatic balance state.

- Step 4: Control the self-balancing scooter left and right.
- Step 5: Get off the self-balancing scooter (One foot on the ground first and the other foot on the deck for balancing).

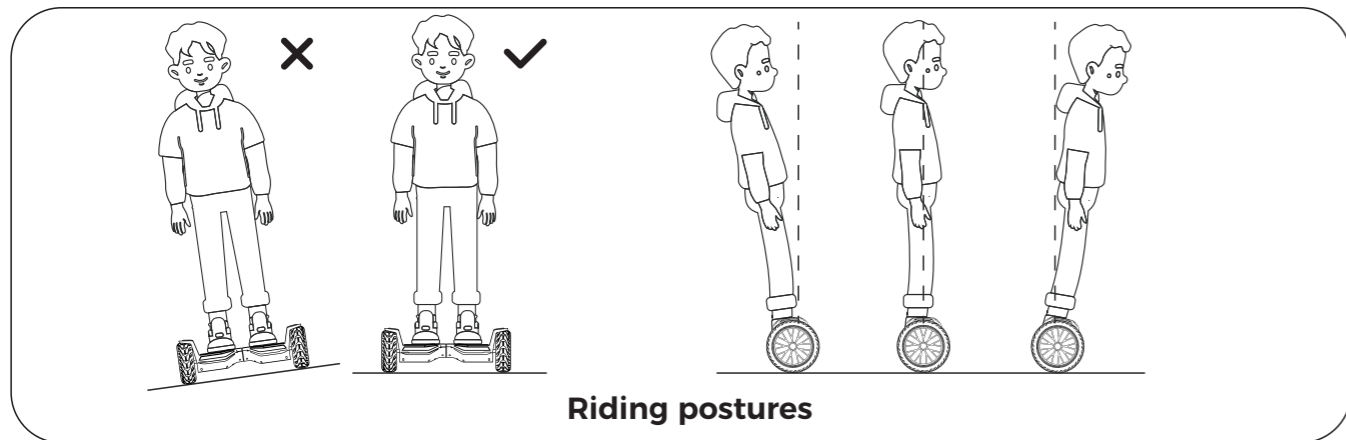
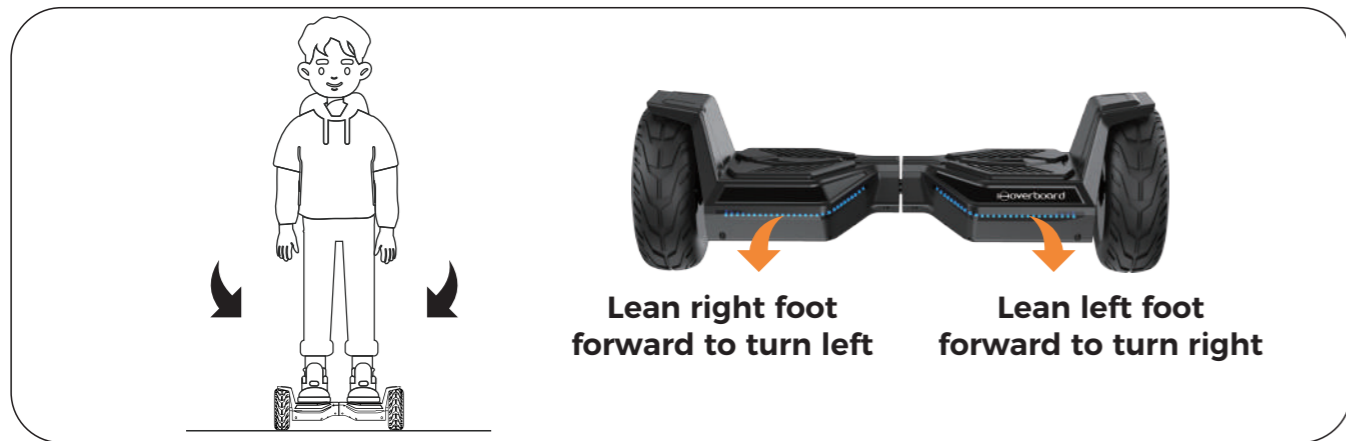

**⚠ WARNING!**

- It is forbidden to make sharp turns at high speed to avoid danger.
- Riding or turning on a cross slope will cause the balance angle to deviate, which will affect riding safety.

**Protections**

During operation, if there are system errors or abnormalities, the smart self-balancing scooter will prompt the rider in different ways. When riding is prohibited, the warning light is always on, the buzzer beeps intermittently, and the system cannot enter the balance mode.

The common situations are as followings:

1. The decks is tilted forward or backward more than 10 degrees.
2. The battery voltage is too low. When the battery voltage is lower than the protection value, it will enter stop state after 15 seconds; if it continues to discharge with high current (such as climbing a long slope for a long time), it will enter stop state after 15 seconds.
3. Speeding.
4. Low battery level. When the body of the self-balancing scooter swings back and forth for more than 30 seconds, the system will enter protection mode, the alarm light becomes always on, and the buzzer sounds high-frequency during the alarm cycle.

## **⚠ WARNING!**

When the battery is exhausted or the system issues a safety stop notification, please stop riding, the self-balancing scooter will not be able to balance due to lack of power, and the rider is likely to be injured in this case. When the battery reaches its minimum, continuing riding will affect the life of the battery.

### ● **Riding Practice**

When you ride outdoors, for your safety, please make sure you can ride it proficiently. Please wear comfortable sportswear and flat shoes for flexibility.

Practice riding in the open until you can get on/off, go forward/back, turn left/right, and stop with ease.

Pay attention to the flatness and slope of the ground. You can learn to ride on different terrains, and you must slow down when encountering unfamiliar terrains. Do not keep the self-balancing scooter off the ground in riding.

The intelligent self-balancing scooter is an auxiliary means of transportation specially used on flat roads. Slow down when driving on uneven roads.

If you are not skilled enough to ride, avoid places where there are dangers such as pedestrians or obstacles. Carefully go through the door and see if you can get through.



## **Safety Riding Instructions**

This section focuses on some safety knowledge and warning words, so that you can have a certain understanding of safety precautions in the process of using the self-balancing scooter. To ensure that you can ride safely, please be sure to read the "Operating Instructions Manual" and follow the relevant safety instructions. Please heed all usage precautions regarding safety warnings in the Operating Instructions Manual. Knowing these safety issues can improve your riding safety and enjoyment.

## **⚠ WARNING!**

- Do not use the self-balancing scooter in any situation where you may lose control, bump, fall, or cause injury. In order to avoid damage, you must carefully read and refer to the instruction manual to ride the self-balancing scooter. Please ensure that the product is in good condition, and only use this product after carefully reading and being familiar with all product information provided.
- When you are learning to ride, make sure you take all safety precautions such as wearing a helmet, knee pads, and elbow pads.
- Self-balancing scooters are only suitable for personal entertainment and are prohibited from being used on public transport.
- It is strictly forbidden to use this product on the motorway.
- Children weighing less than 20kg are not allowed to ride. Adult protection is needed for children when riding. Elderly people with a history of heart disease, high blood pressure, or lack of awareness of self-protection are prohibited from riding. Pregnant women and the disabled are not allowed to ride.
- It is forbidden to ride under the influence (after drinking or taking medicines). Do not carry items that may result in overload while riding.
- Please obey the local traffic laws and give way to pedestrians.

- Please pay attention to things in front and far away. Maintaining a good vision will help you ride more safely.
- A slight bend in the knees will help you maintain your balance when riding over uneven surfaces.
- During riding, make sure that your feet are always on the decks.
- Wearing sports-friendly clothing can help you better handle emergencies.
- No passengers are allowed.
- The weight of the rider and belongings must not exceed the maximum load indicated in the manual; otherwise, the rider will be more likely to fall, get injured, or even cause damage to the functions of the self-balancing scooter. In addition, the weight of the rider should not be lower than the minimum weight mentioned above, otherwise the rider will not be able to control the self-balancing scooter, causing safety hazards, especially when decelerating downhill or stopping.
- You must keep the self-balancing scooter at a speed that is ready to stop at any time to ensure the safety of yourself and others.
- When an accident occurs in riding a self-balancing scooter, please wait for the relevant department to arrive at the scene to deal with it reasonably and legally.
- When riding with other self-balancing scooters, please keep a certain distance to avoid collisions.
- Please keep in mind: Your height has increased by about 10 cm when riding, please pay attention to safety.
- When turning, pay attention to the balance of the center of gravity to prevent falling due to shifting of the center of gravity or turning too fast.
- Do not ride with distractions such as answering a phone call, listening to music or engaging in any other activity.
- It is strictly forbidden to ride in the rain, backtrack for a long distance, overspeed, brake suddenly, or turn at high speed.
- Do not ride in dimly lit or dark places.
- Avoid obstacles and slippery road surfaces (such as snow and ice).

- Please avoid riding on rubbish or scattered twigs on small stone roads.
- Avoid riding in narrow spaces or places with obstacles.
- Please abide by the conditions of use of the self-balancing scooter site. If any site requires a license, please obtain the license first.
- Please do not start or stop suddenly.

Avoid riding on steep slopes.

It is forbidden to use the self-balancing scooter in an unsafe environment, which refers to a place where there are flammable gases, vapors, liquids, dust or fibers that may cause dangerous events such as fire or explosion.



## Battery Charging and Care

How to charge the battery, how to maintain it, safety precautions, and battery specifications. For your safety and the safety of others, and to maximize battery life and battery performance, be sure to use the battery as follows.

### ● Lack of battery

When you find that the power indicator light is red and flashing, it indicates that the battery level is low. It is recommended to stop riding. When the battery level is low, the self-balancing scooter does not have enough power to enable normal ride, the system will prohibit further use. If you insist on riding at this time, it is easy to fall and get damaged, and it will also affect the service life of the battery.

If you notice any of the following, please discontinue use.

1. Odor or overheating.
2. Spill any substance.

Note:

- Removal and maintenance of the battery is limited to staff only.
- Do not touch any leaked material.
- Keep the battery out of reach of children. The charger must be unplugged before installing the battery or riding. Doing anything with the self-balancing scooter while charging is dangerous.
- The battery contains dangerous substances, please do not disassemble the battery or insert any material into the battery.
- Only use the original battery.
- Unsafe use of lithium batteries is prohibited. Excessively discharged batteries can only be discarded.
- Use the battery of the self-balancing scooter as permitted by local law.

### ● Charging Steps

Make sure the charging port is dry and open the charging port cover.

- Step 1: First plug the AC end of the charger into a wall outlet (100-240V, 50-60 Hz), confirm that the indicator light of the charger is always-on green light. And then plug the DC connector of the charger into the charging port of the self-balancing scooter.
- Step 2: When the red indicator on the charger lights, it means the charging is normal. If not, please check whether the circuit connection is good.
- Step 3: When the red indicator light on the charger turns to green light, it means it is fully charged. Please stop charging as long time charging will affect the service life of the battery.



Note:

- Pay attention to use the local standard wall plugs.
- Please charge and store the battery according to regulations, otherwise it will damage the battery and affect the battery life.
- The battery charging time is about 4-5 hours. Charging the battery too long will affect the battery life.
- Please keep the charging environment clean and dry.
- Do not charge when there is water in the charging port.



- **High or low temperature**

To charge the battery with the most efficiency, its battery temperature before and during charging must be within the marked temperature range. If it is extremely cold or hot, the charging time will be prolonged or it will not be fully charged.

- **Battery parameters**

Item	Parameters
Battery type	Lithium battery
Charging time	4 or 5 hours
voltage	36V
Initial capacity	4Ah
Working temperature	-15°C~+50°C
Charging temperature	0~40°C
Storage time	12 months (-20°C~+25°C)
Stored relative humidity	5%-95%

- **Precautions when transporting batteries**

**⚠WARNING!** Lithium batteries are dangerous, get local law permission when transporting them.

**NOTE :** If you need to transport the lithium-ion battery of the two-wheeled self-balancing scooter by air, or other transportation methods, please contact the company's designated agent.



## Contact us



[support@ihoverboard.co.uk](mailto:support@ihoverboard.co.uk)



<https://www.ihoverboard.co.uk>

