

**Great
Little**
Trading Co.

gltc.co.uk

Fleming Desk L3818

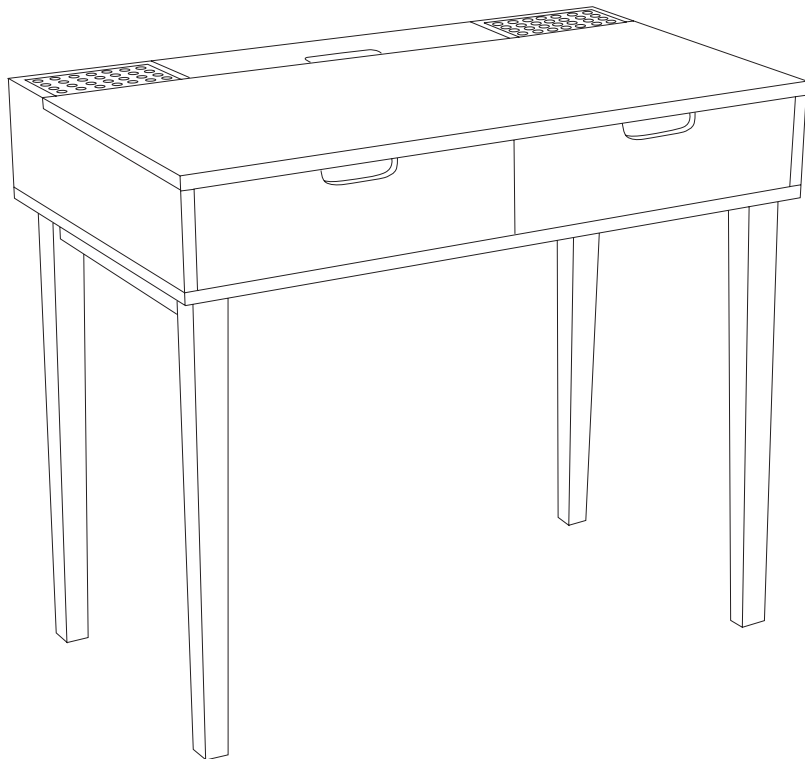

Assembly Difficulty



easy - medium - hard



one-person job

V2

28/11/2016

Thank you for shopping with GLTC, we hope you enjoy having this product in your home.

We know assembling furniture, toys or accessories is not everyone's favourite way to spend their time, so we've tried to make assembling this item as quick and painless as possible.

Hopefully our efforts will have been worthwhile and you'll sail through the whole process. But if it all feels a bit too much like hard work, then we do have an assembly company we can recommend: the Flatpack Construction Company offers a nationwide service and can be contacted on **0843 289 4951** or **www.flatpackconstruction.co.uk**.

A few important pointers before you start:

- Please read the instructions right through before you start, and check that all the components have been included in the pack; we find separating all the hardware into piles makes it easier to be sure that everything is present and correct.
- Make sure you have the right tools. Allen keys are provided if required, but screw drivers and other tools are not. You'll find details of the tools you need at the beginning of the instructions.
- It's a good idea to build the unit in the room where you are going to be using it, to avoid the need to move it after it's been assembled.
- Do not throw away any packing materials until assembly is complete, just in case you accidentally discard smaller parts or hardware.

Safety Warnings:

- Adult assembly required.
- Unassembled product contains small parts which may present a choking hazard.
- Children should be kept away from the product during assembly to avoid any possible risk of injury.
- Assemble and use on a flat and level surface.
- DO NOT use power tools in the assembly of this product as there is a risk of over-tightening and consequently splitting of the wood.
- Check all fixtures and fittings regularly and tighten as necessary.
- Please retain these instructions for future reference.

Customer Service:

- If you find that any components are missing or damaged, please do not begin assembly and do not use the item. Please contact GLTC Customer Services on **0344 848 6000** immediately.
- We do stock spare hardware packs at our warehouse, so we should be able to send you a replacement pack immediately if required.

Product Care:

- Wipe clean using a soft damp cloth followed by a dry cloth.
- The painted/lacquered surface is resistant to staining if cleaned immediately, however please protect the surface from contact with ball point pen and indelible style felt markers as the ink is by nature permanent.
- Do NOT use cleaning products which contain ammonia, solvents or abrasive material.
- Do NOT expose the item to extremes of heat and humidity.





Could we do better?





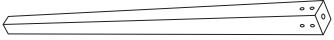
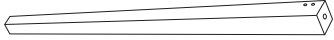
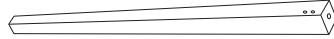
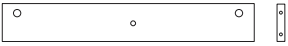

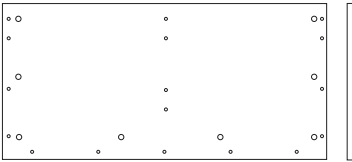
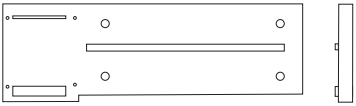
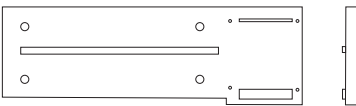
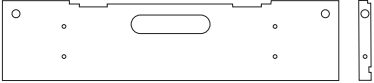
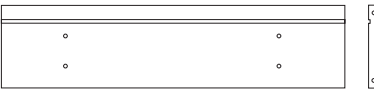
If there is anything you think could be improved in these instructions or in the assembly of this product we'd be grateful if you could let us know; we'll pass any helpful hints and tips on to other customers via our website and update the instructions.

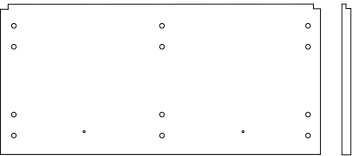
All you need to do is drop us a line at instructions@gltc.co.uk

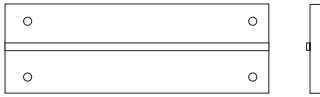
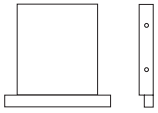



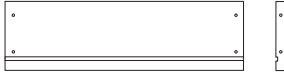

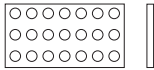

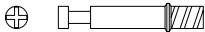

Thank you

Component Check List

| | |
|---|---|
| <p>A</p>  <p>2x Leg A</p> | <p>B</p>  <p>1x Leg B</p> |
| <p>C</p>  <p>1x Leg C</p> | <p>D</p>  <p>2x Panel D</p> |
| <p>E</p>  <p>1x Panel E</p> | <p>F</p>  <p>1x Panel F</p> |
| <p>G</p>  <p>1x Panel G</p> | <p>H</p>  <p>1x Panel H</p> |
| <p>I</p>  <p>1x Panel I</p> | <p>J</p>  <p>1x Panel J</p> |
| <p>K</p>  <p>1x Panel K</p> | <p>L</p>  <p>1x Panel L</p> |

| | |
|---|---|
| <p>M</p>  <p>1x Panel M</p> | <p>N</p>  <p>2x Panel N</p> |
| <p>O</p>  <p>1x Panel O</p> | <p>P</p>  <p>1x Panel P</p> |
| <p>Q</p>  <p>1x Panel Q</p> | <p>R</p>  <p>2x Panel R</p> |
| <p>S</p>  <p>4x Panel S</p> | <p>T</p>  <p>2x Panel T</p> |
| <p>U</p>  <p>2x Panel U</p> | |
| | |

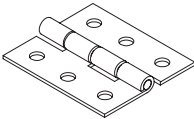
Component Check List

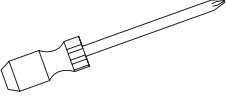
| | |
|--|---|
| <p>#1</p>  <p>20x Cam Dowels 35mmL</p> | <p>#2</p>  <p>20x Cam Locks 14mm Diameter</p> |
| <p>#3</p>  <p>26x Wooden Dowels 20mmL</p> | <p>#4</p>  <p>2x Drawer Stop</p> |
| <p>#5</p>  <p>14x Screws 10mmL</p> | <p>#6</p>  <p>16x Screws 20mmL</p> |
| <p>#7</p>  <p>11x Screws 25mmL</p> | <p>#8</p>  <p>4x Barrel Nuts</p> |
| <p>#9</p>  <p>8x Threaded Bolt 42mmL</p> | <p>#10</p>  <p>2x Hinges</p> |
| <p> 1x Allen Key</p> | <p>You will need (not supplied)</p>  Philips Head Screwdriver |

STEP 1:

Prepare the desk legs.

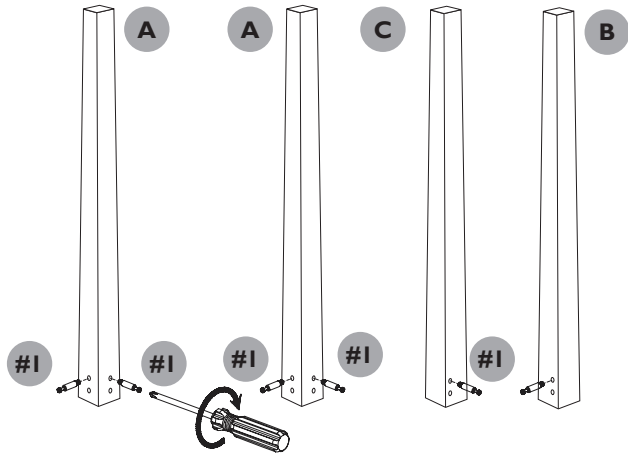

Hardware for Step 1:

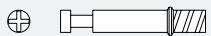

6x #1 Cam Dowels

STEP 2:

Create each pair of legs by connecting them with panel D, as shown. Turn all cam locks (#2) clockwise to secure.

Note the positioning of both legs labeled A. Ensure the remaining cam dowels are facing towards each other as shown.

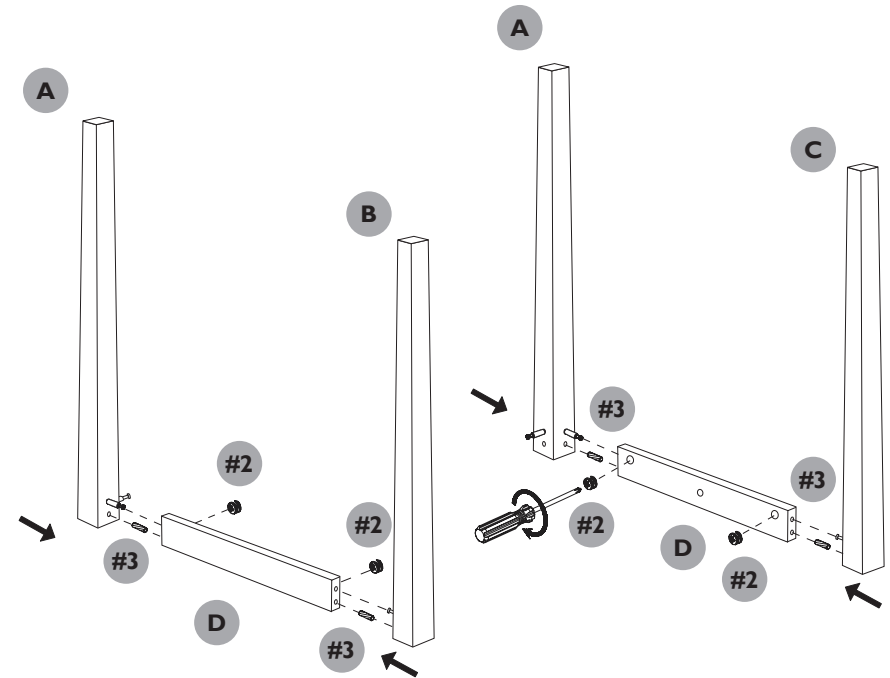

Hardware for Step 2:



4x #2 Cam Locks



4x #3 Wooden Dowels

STEP 3:

Connect both pairs of legs using panel E. Turn both cam locks (#2) clockwise to secure.

Ensure all hardware is facing inwards as shown.

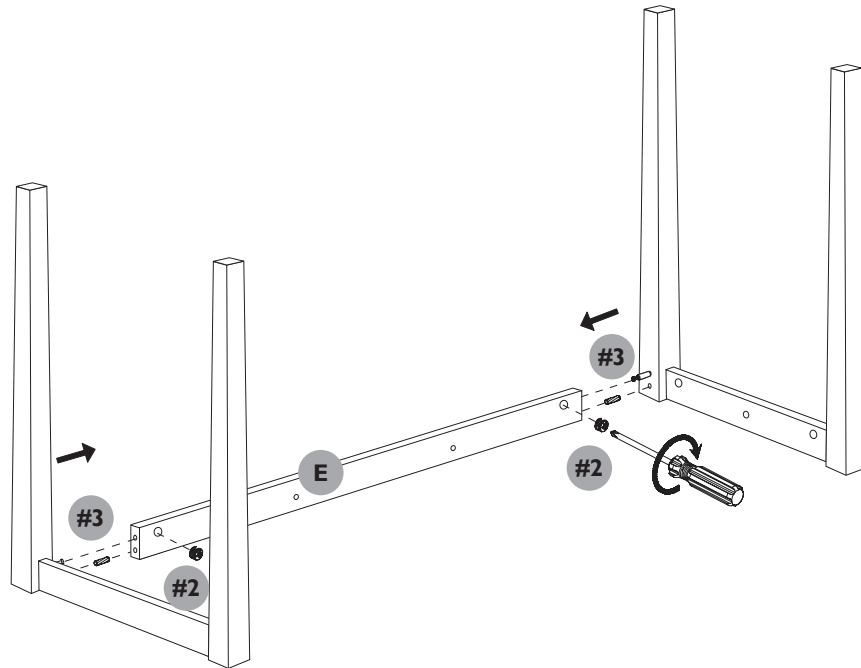

Hardware for Step 3:



2x #2 Cam Locks



2x #3 Wooden Dowels

NOTE:

Please be aware that when assembling the legs to panels D and E you may notice that the legs remain loose after the cam locks have been tightened. These will be secured during the next step.

Hardware for Step 4:



8x #9 Bolts



4x #8 Barrel Nuts

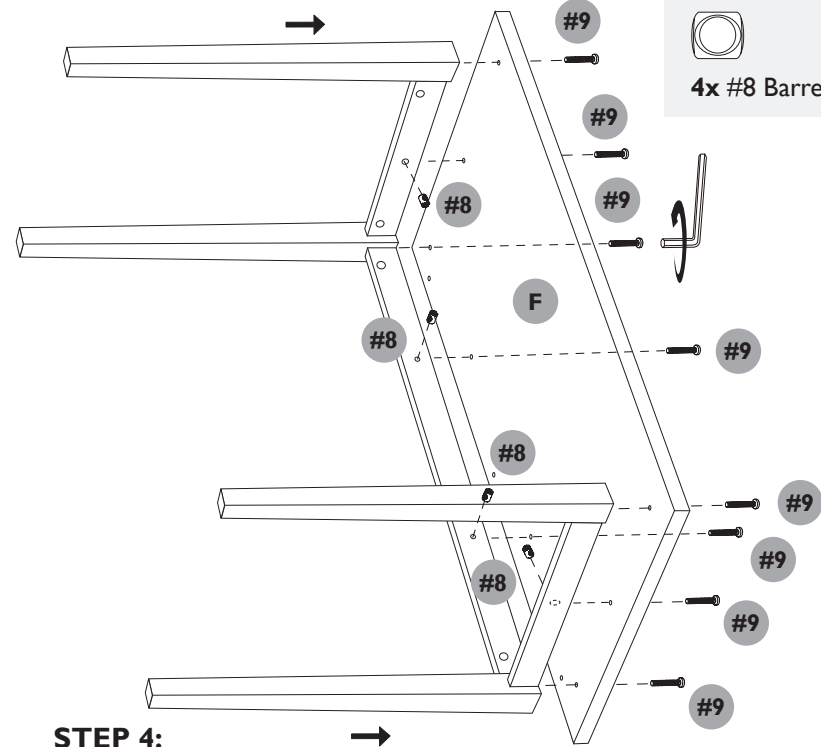

STEP 4:

Attaching the legs to the desk storage.

Begin with inserting the 4 x threaded bolts (#9) directly into the 4 legs. Fully tighten these bolts using the Allen key provided. It is important that they are tightened fully.

The remaining four bolts (#9) need corresponding barrel nuts (#8) to hold them in place. Again, it is important that they are tightened fully.

Please note, panel F must be positioned with the larger drill holes facing away from the legs. The hardware (#9) must insert into the larger holes and must be tightened fully so that each bolt head is recessed into the panel as they will not be accessible after this step.

This step can also be completed with the legs set upright on the floor and panel F placed on top of them.

STEP 5:

With the base of the desk on its feet. Insert hardware #1 and #3 as shown.

Please ensure the hardware is positioned as illustration. Not all holes will be used here, they will be used on a later step.

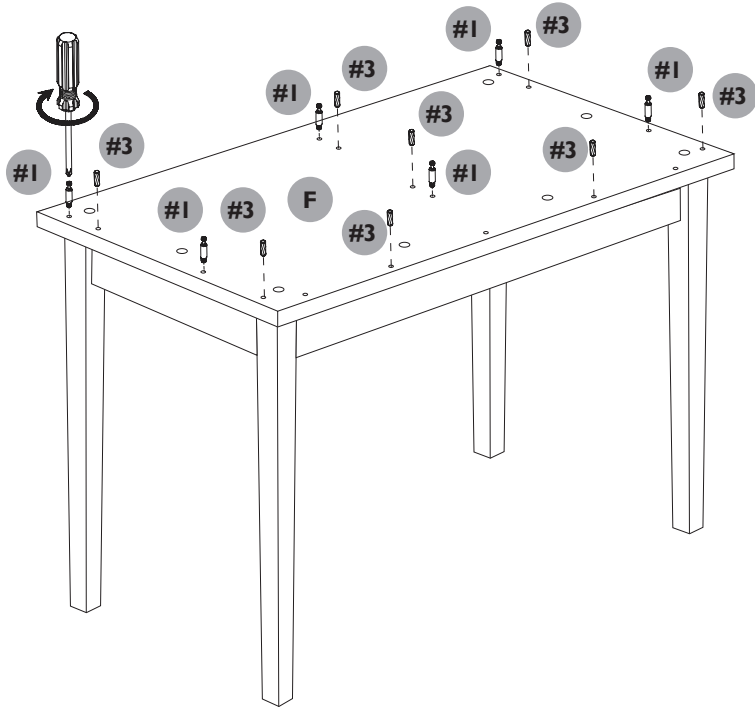

Hardware for Step 5:

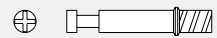

6x #1 Cam Dowels



8x #3 Wooden Dowels

STEP 6:

Prepare the sides of the desk storage by inserting 1x cam dowels (#1) into each of the panels as shown.

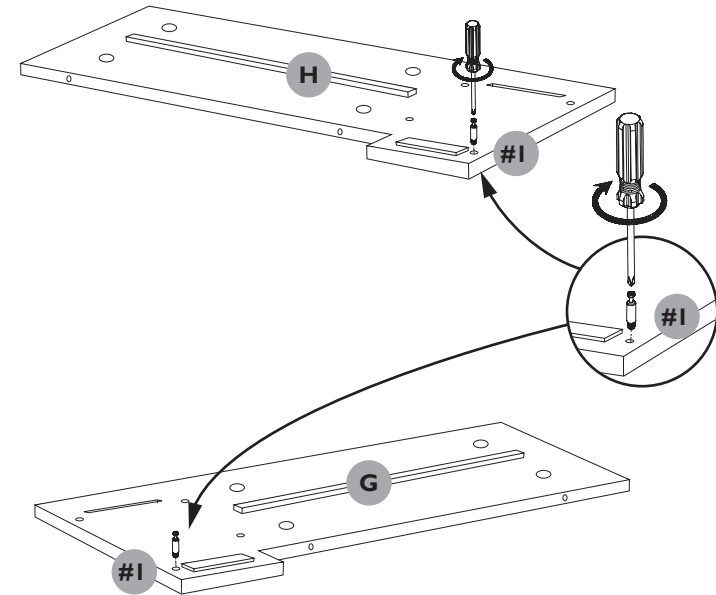

Hardware for Step 6:

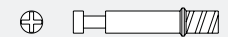

2x #1 Cam Dowels

STEP 7:

Begin to construct the desk storage. Add 3x wooden dowels (#3) to Panel H as shown before attaching the other panels. Lock panel I into place with cam lock #2.

Slide in panel K when panels I and J are in place.

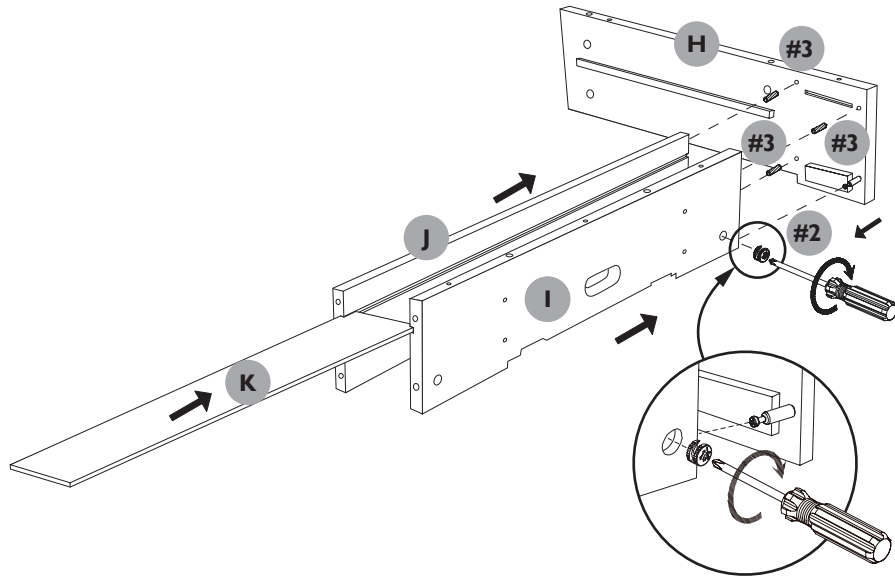

Hardware for Step 7:



1x #2 Cam Locks



3x #3 Wooden Dowels

STEP 8:

Connect panel G to the other side of the panels as shown with 3 x wooden dowels (#3) and lock into place with cam lock #2.

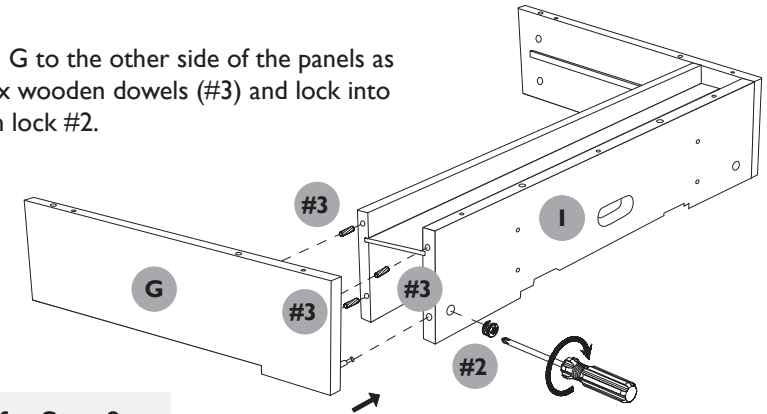

Hardware for Step 8:



1x #2 Cam Locks



3x #3 Wooden Dowels

STEP 9:

Take panel L and insert 6x cam dowels (#1) as shown. Also attach the 2x drawer stops (#4) using screw #5.

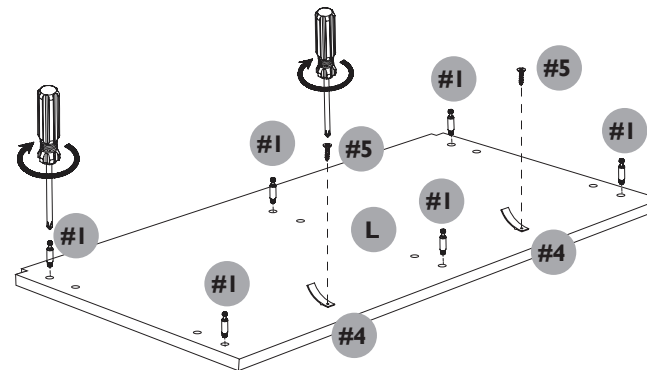

Hardware for Step 9:

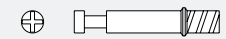

6x #1 Cam Dowels



2x #4 Drawer Stop



2x #5 Screws

STEP 10:

Connect panel L with the divider panel M and the part constructed desk storage.

First insert 6x wooden dowels (#3) into panel L as shown.

Then place the central divider panel M over the dowels and secure in place by inserting and turning the two cam locks (#2).

Then take the part constructed desk storage and place on the top of panel L, again securing by inserting and turning the four remaining cam locks (#2) on the side panels.

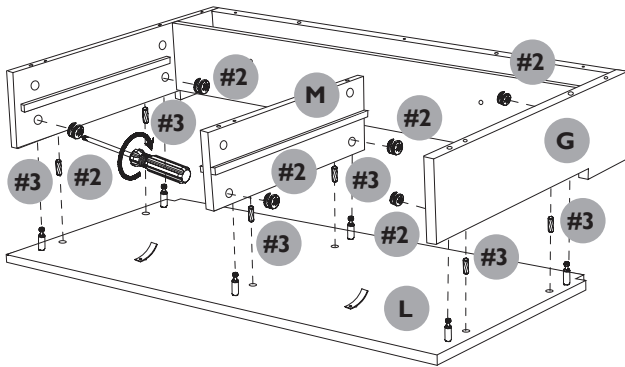

Hardware for Step 10:



6x #2 Cam Locks



6x #3 Wooden Dowels

STEP 11:

Insert the storage dividers.

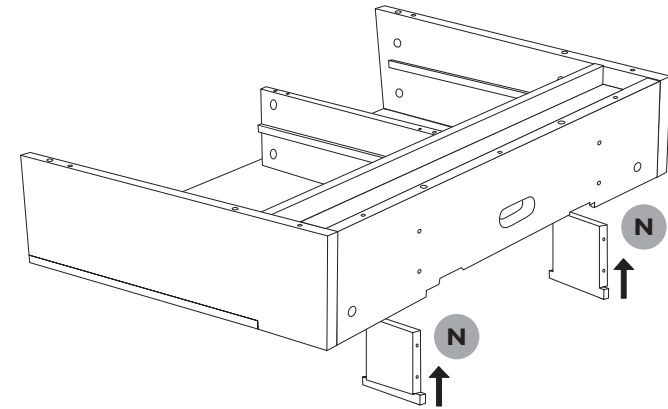

STEP 12:

Secure the storage dividers in place.

Ensure the dividers are straight and in the correct position before inserting the screws.

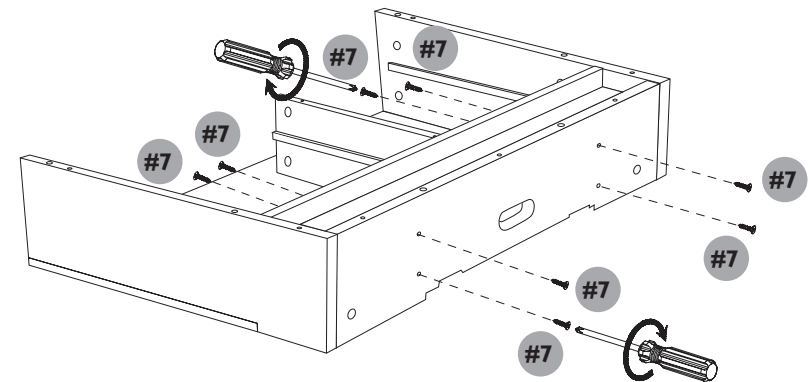

Hardware for Step 12:

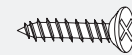

8x #7 Screws

STEP 13:

Turn the desk storage over and place on top of the legs. Ensure all the hardware in the leg section is inserted into the corresponding holes in the storage section.

Begin securing the two sections by inserting 3 x Hardware #7 in the holes shown.

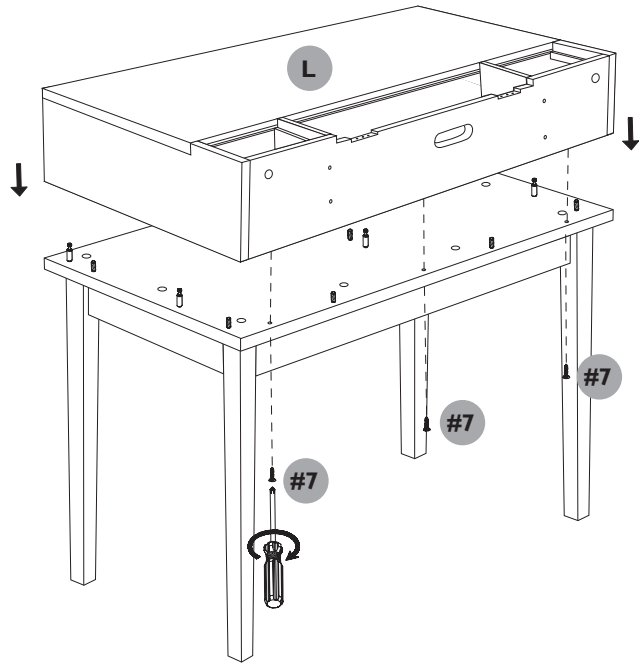

Hardware for Step 13:

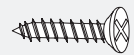

3x #7 Screws

STEP 14:

Complete the fixing of the desk top to the legs by inserting and securing 6x cam locks (#2).

Remember to secure the 3 cam locks at the very back of the drawer section that has been created.

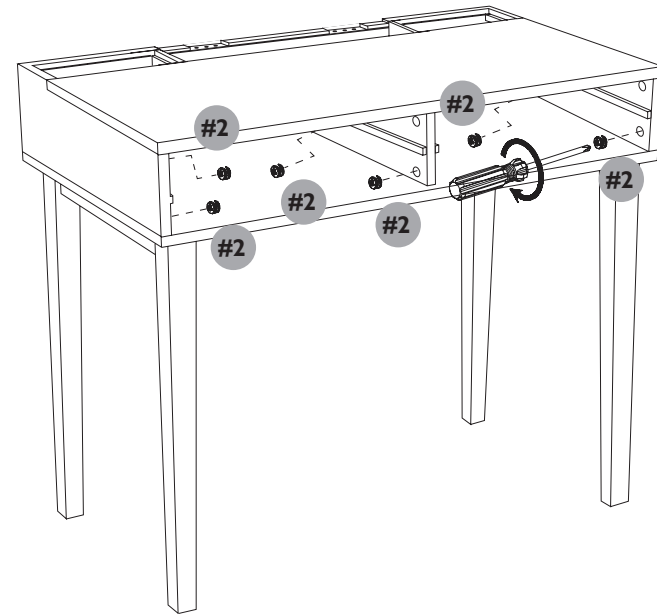

Hardware for Step 14:



6x #2 Cam Locks

STEP 15:

Attach the lift up storage lid.

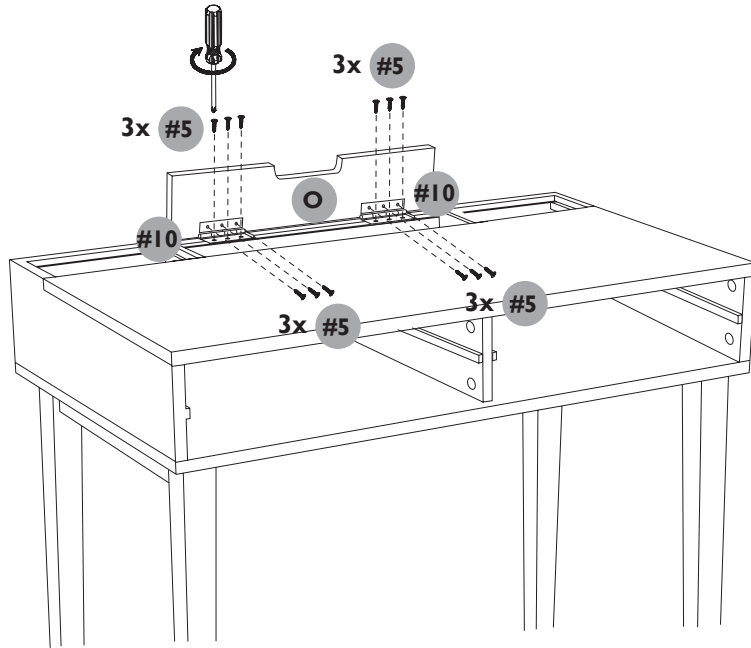

Hardware for Step 15:



12x #5 Screws

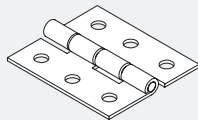

2x #10 Hinges

STEP 16:

Create the first drawer, using drawer front P.

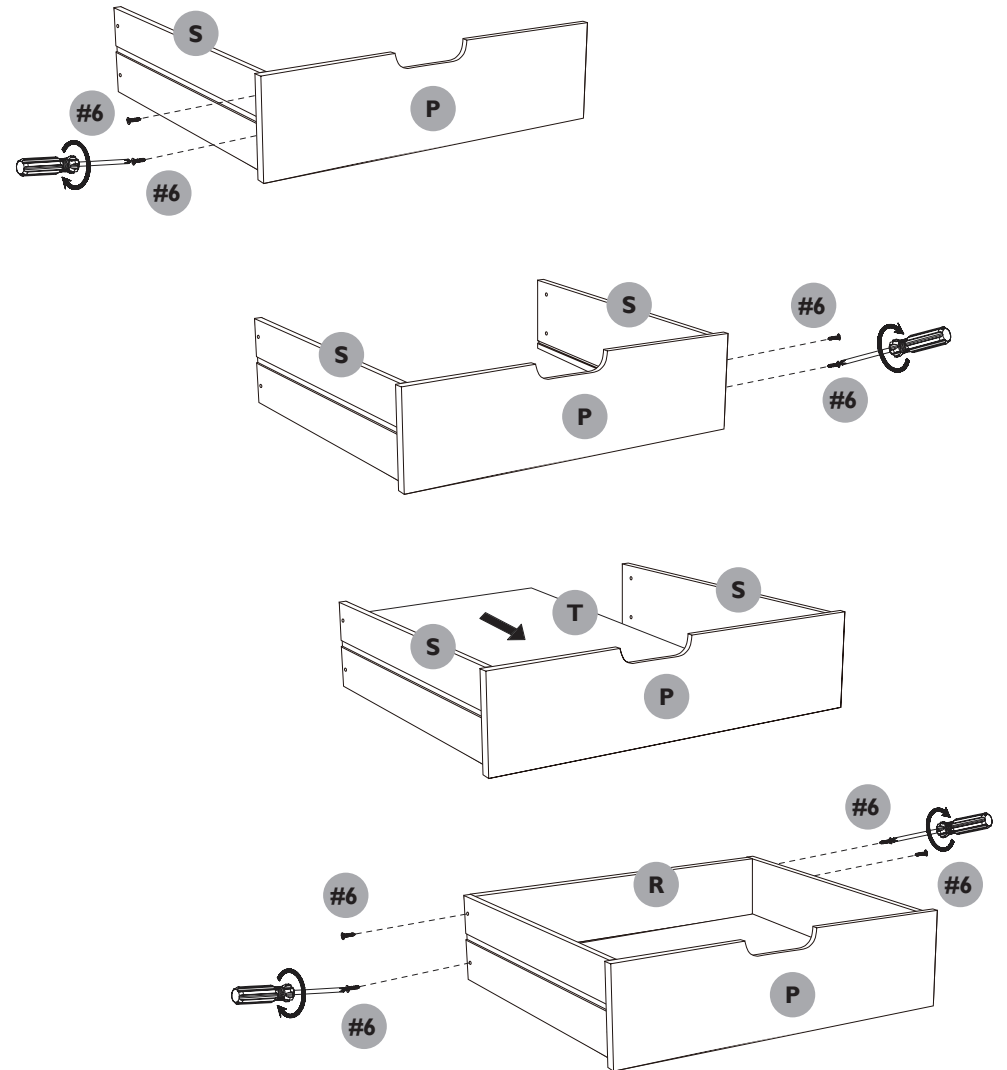

Hardware for Step 16:

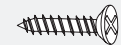

8x #6 Screws

STEP 17:

Create the second drawer, repeat step 16 with drawer front Q.

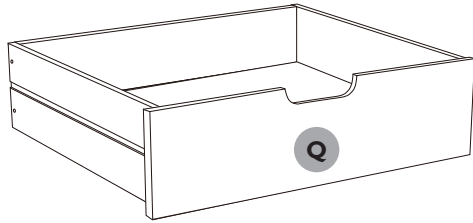

Hardware for Step 16:



8x #6 Screws

STEP 18:

Complete the desk by inserting the pen holder panels and the drawers.

