

# ASSEMBLY INSTRUCTION

Accent chair





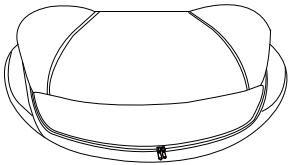
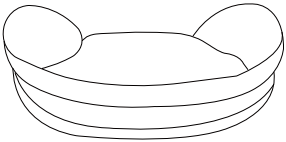
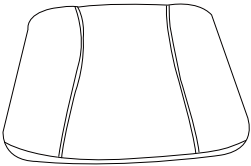
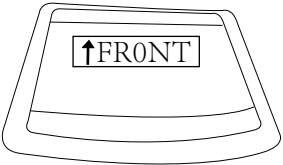
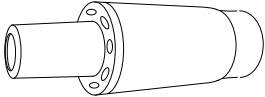
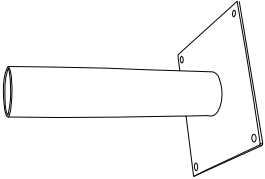
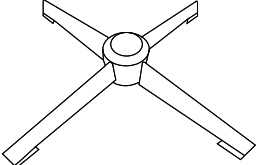
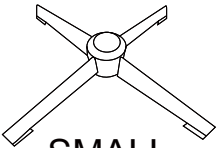

DY- WX 18839 -42-1PC



# Component List

LABEL		DESCRIPTION	QTY
A		Chair Back	1
B		Chair Seat	1
C		Footrest Cushion	1
D		Footrest Frame	1
E		Gas Lift	1
F		Metal Rod	1
G	 <p data-bbox="587 1843 655 1877">BIG</p>	Chair Base	1
H	 <p data-bbox="568 2074 692 2107">SMALL</p>	Footrest Base	1

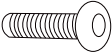
# Hardware List

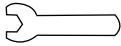
LABEL		DESCRIPTION	QTY
H1		Hanger Bolts	3
H2		Hex Nut	3
H3		Flat Washer	3
H4		Spring Washer	3
H5		Bolts	4
H6		Allen Key	1
H7		Wrench	1

## Assembly Steps

1

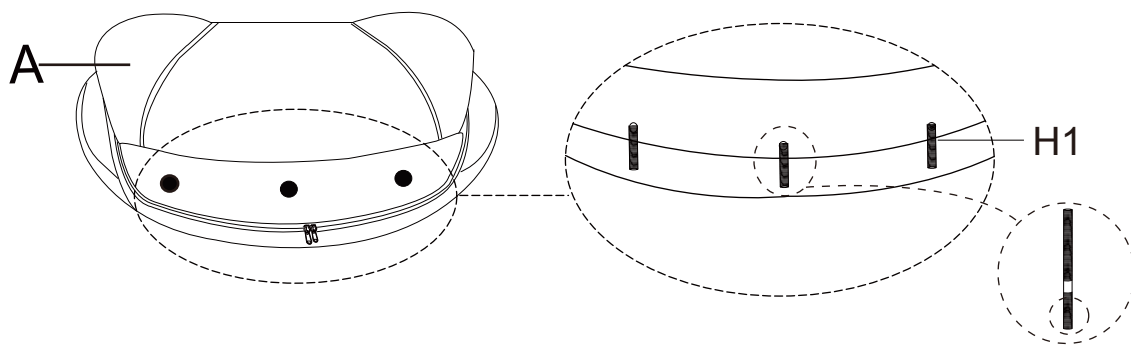

Place chair back (A) on a clean padded surface, fasten bolt (H1) to insert on bottom edge of the chair back (A)

# Assembly Steps

2

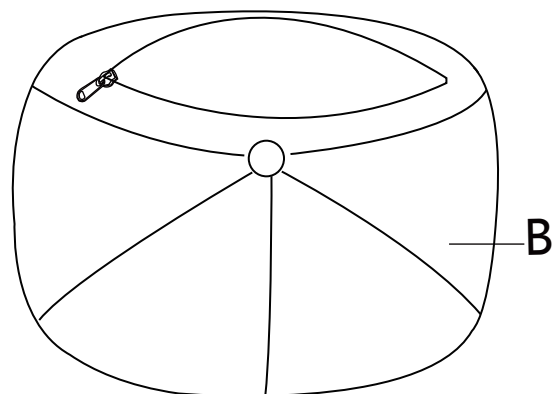

Open zipper pocket under the chair seat (B)

3

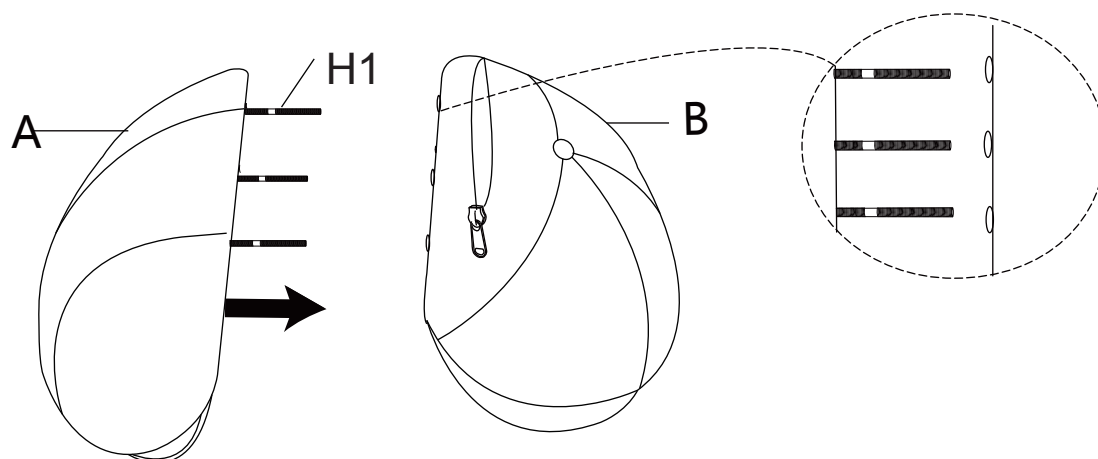

Carefully align then insert bolts through holes on edge of chair seat (B)

# Assembly Steps

4

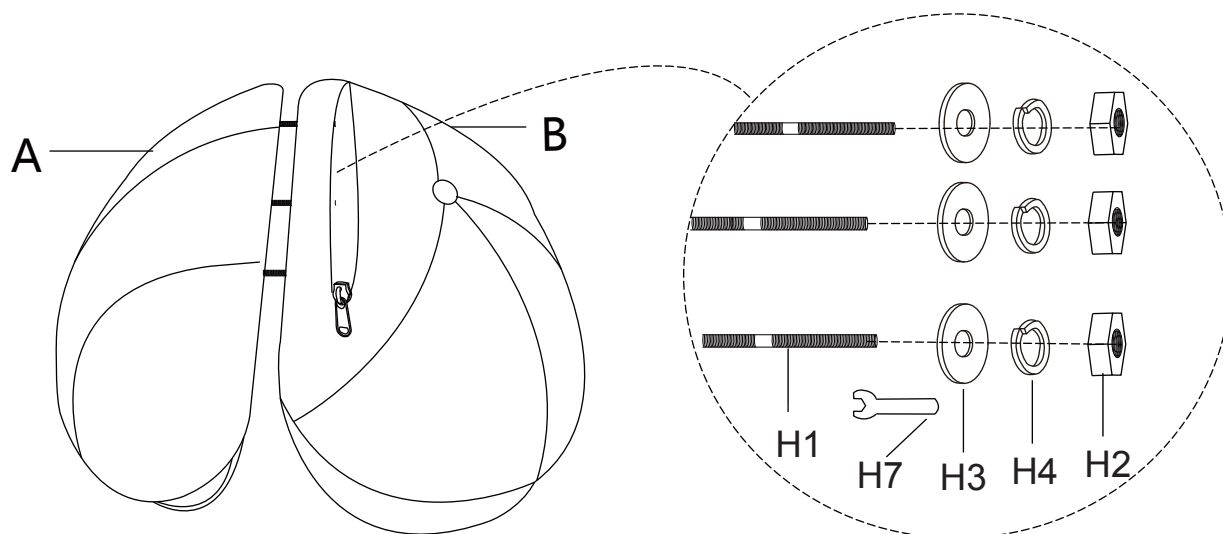

Pierce the non-woven fabric on the inside of chair B  
Attach flat washer (H3),spring washer (H4),hex nut (H2) to bolts (H1)  
then fasten to secure.

5

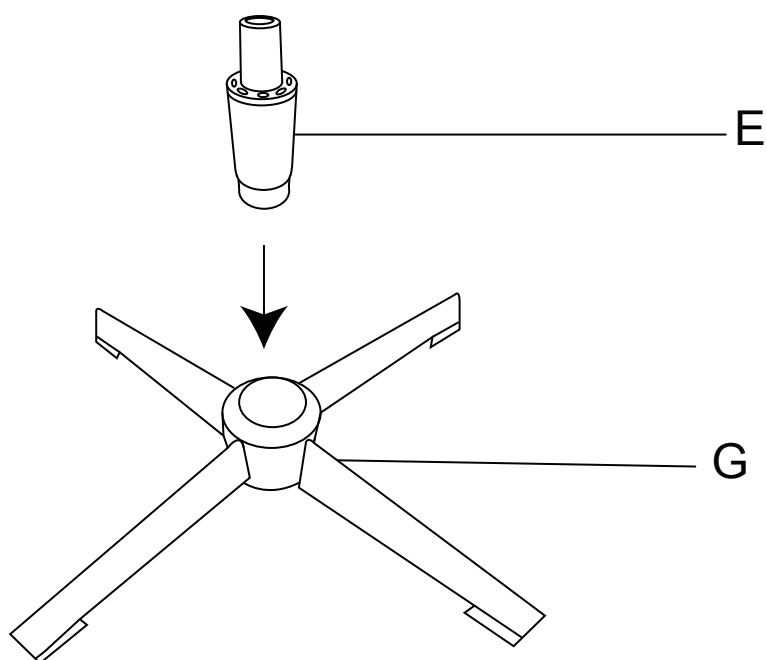

Insert lift(E) to the metal base(G)

## Assembly Steps

6

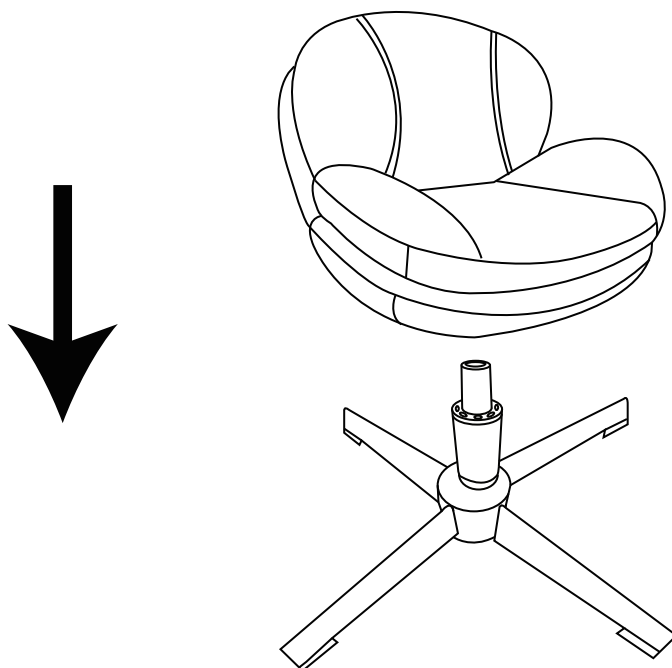

Carefully align center post (E) with hole on bottom of the chair seat (B)

7

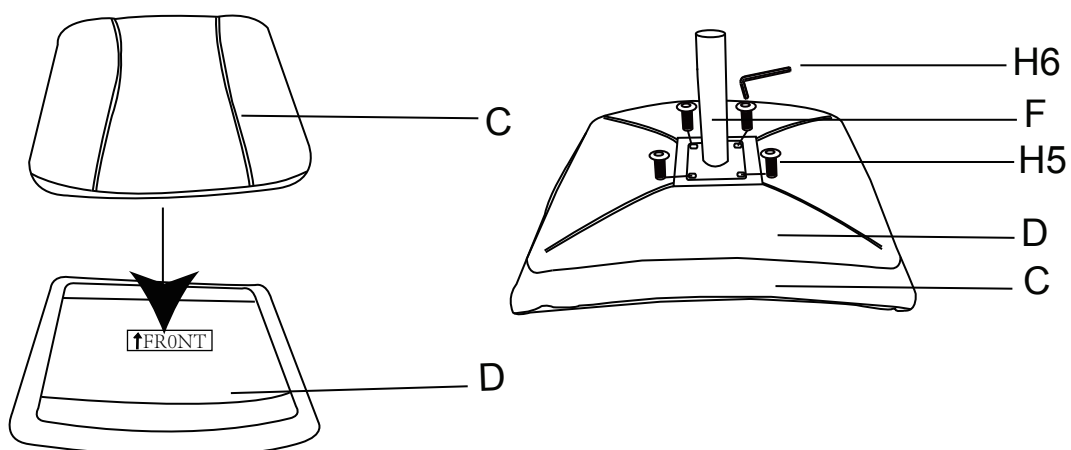

Stick footrest cushion (C) onto footrest frame (D), then assembly the metal rod (F) to footrest frame with BOLTS (H5).

## Assembly Steps

8

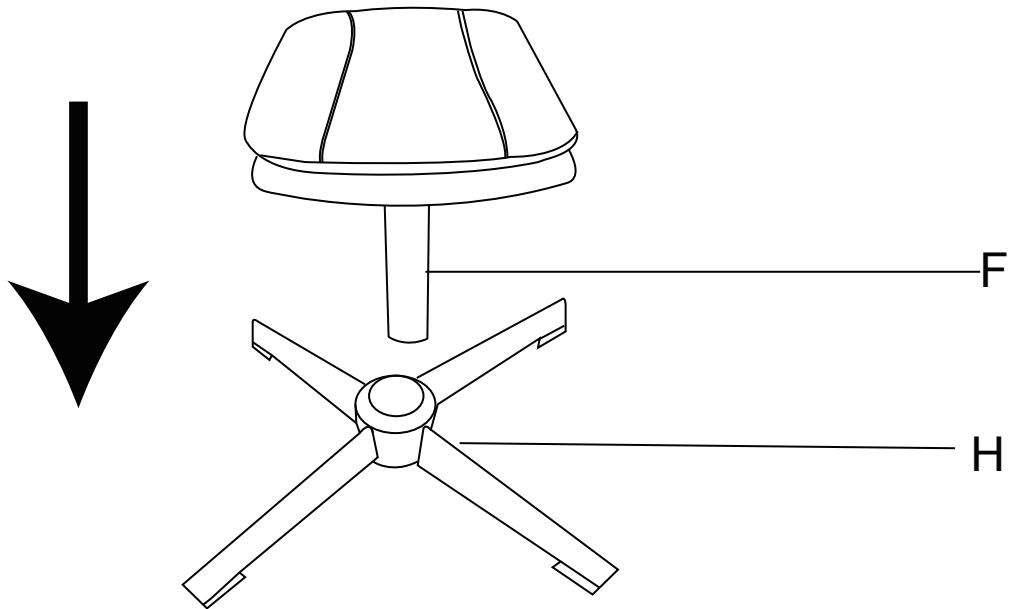

Insert the metal rod (F) into the footrest base.

9

