

RO/HOBBY

1:12 TYPE82 KUBELWAGEN

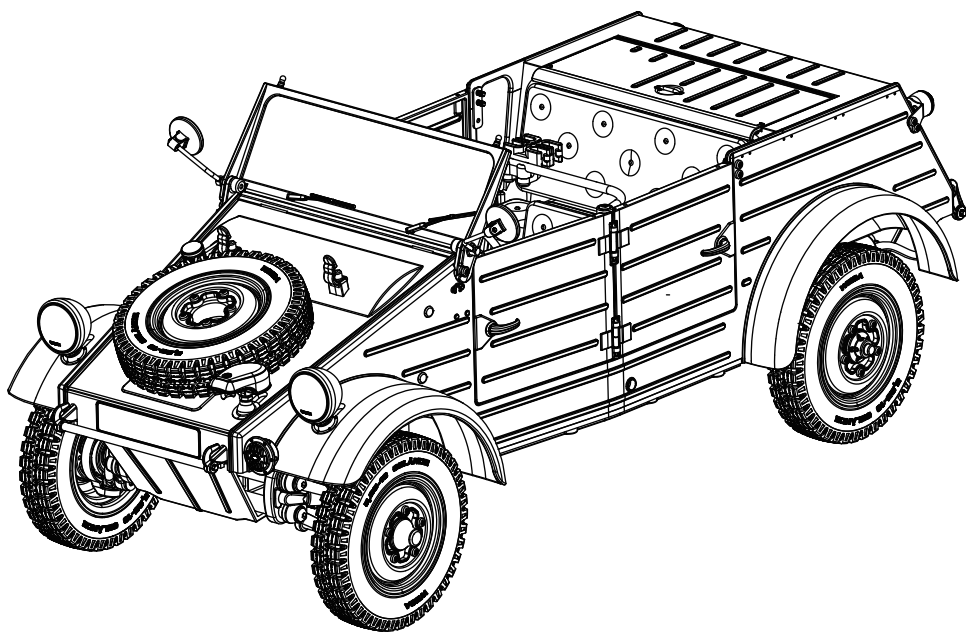

Instruction Manual
Bedienungsanleitung
Manuel d'utilisation
操作手册

SPECIFICATION

Length: 317mm
Width: 135mm

Height: 129mm
Wheel base: 202mm

Ground clearance: 28mm
Approach angle: 40°

Departure angle: 60°

TABLE OF CONTENTS

SAFETY PRECAUTIONS	03
RADIO SYSTEM	05
PRODUCT INTRODUCTION	06
THROTTLE STICK POSITION	18
VEHICLE SETUP	18
OPERATING THE VEHICLE	19
TRANSMISSION	82
CAR SHELL	84
CHASSIS	86
REAR WHEEL	88
RIGHT-FRONT WHEEL	88
ACCESSORIES LIST	89

SAFETY PRECAUTIONS

Introduction

This manual is written to assist you in properly operating, maintaining and repairing the vehicle. As many of the components used are unique to this truck, please retain this manual as a future reference.

Composed of precision-made components, the Rochobby 1:12 Suzuki Jimny is not a toy, thus it is not suited for children under 14 years of age. Minors should be accompanied by an adult when operating. Failure to operate or maintain this vehicle in a safe manner can result in bodily harm. It is the owner responsibility to operate this product in a safe manner. Rochobby and its distributors are not responsible in any way for any and all bodily harm and/ or property damage that may result from the use of this product. Replace damaged components with original factory-parts. Pay special attention to the polarity of all vehicle wiring.

Safety, precautions and warnings

- Replace damaged components with original factory-parts. Pay special attention to the polarity of all vehicle wiring.
- Use common sense when selecting the environment to operate your vehicle. Do not operate near power cables, cellular/radio towers, deep water or unstable terrain. The operator is solely responsible for their actions.
- The product is composed of precision electrical components. It is critical to keep the product away from moisture and other contaminants.
- Always check the radio range of the vehicle prior to operation in order to prevent radio loss or interference.
- Operate this product within your ability. If the vehicle is dangerous to retrieve, it never worth the risk.
- Always turn on the transmitter before connecting the battery on the model. When turning off the model, always disconnect the battery first, and then turn off the model, always disconnect the battery first, and then turn off the transmitter. If this order is reversed, the model may become uncontrollable and cause serious damage.
- Never allow transmitter batteries to run low as it may cause loss of vehicle control.
- Plastics on the vehicle are susceptible to damage or deformation due to extreme heat and cold climate. Do not store the model near any source of heat such as oven or heater. Store the model indoors, in a climate-controlled, room temperature environment.

CE compliance information for the european union

The associated regulatory agencies of the following countries recognize the noted certifications for this product as authorized for sale and use.

UK	DE	DK	BG	SE	GZ	ES	NL	SK	HU	RO	FR	PT	BE
FI	EE	LV	LT	PL	AT	CY	SI	GR	MT	IT	IE	LU	

Declaration of Conformity
 Products: 2.4GHz Controller
 Equipment Class: 2
 The objects of declaration described above are in conformity with the requirements of the specifications listed below.

Item Name : 2.4GHz Controller
 The RED Directive 2014/53/EU
 EN 60950-1:2006 + A11:2009 + A1:2010
 + A12:2011 + A2:2013
 EN EN 300 328 V2.2.2 (2019-07)
 EN 301 489-1 V2.1.1:2017
 EN 301 489-17 V3.1.1:2017

Please read this manual carefully prior to using. We are not responsible for any intentional damage or improper use. If you require any additional information or have any questions about the product or its use, please contact us via .

This product is not a toy! (14+) Recommended for ages 14 and up. Adult supervision required for ages under 14 years old. Contains small parts, keep out of reach of children 3 years of age and younger.



MADE IN CHINA

Certification

FCC Compliance Statement

This device complies with Part 15 of the FCC Rules. Operation is subject to the following two conditions: (1) this device may not cause harmful interference, and (2) this device must accept any interference received, including interference that may cause undesired operation.

Warning: changes or modifications not expressly approved by the party responsible for compliance could void the user's authority to operate the equipment.

This equipment has been tested and found to comply with the limits for a Class B digital device, pursuant to Part 15 of the FCC Rules. These limits are designed to provide reasonable protection against harmful interference in a residential installation. This equipment generates, uses and can radiate radio frequency energy and, if not installed and used in accordance with the instructions, may cause harmful interference to radio communications. However, there is no guarantee that interference will not occur in a particular installation.

If this equipment does cause harmful interference to radio or television reception, which can be determined by turning the equipment off and on, the user is encouraged to try to correct the interference by one or more of the following measures:

- 1.Reorient or relocate the receiving antenna.
- 2.Increase the separation between the equipment and receiver.
- 3.Connect the equipment into an outlet on a circuit different from that to which the receiver is connected.
- 4.Consult the dealer or an experienced radio/TV technician for help.

RF Exposure Compliance

This equipment complies with FCC radiation exposure limits set forth for an uncontrolled environment. This equipment should be installed and operated with minimum distance 20cm between the radiator and your body. This transmitter must not be co-located or operating in conjunction with any other antenna or transmitter.

Environmentally friendly disposal

Old electrical appliances must not be disposed of together with the residual waste, but have to be disposed of separately. The disposal at the communal collecting point via private persons is for free. The owner of old appliances is responsible to bring the appliances to these collecting points or to similar collection points. With this little personal effort, you contribute to recycle valuable raw materials and the treatment of toxic substances.





FCC ID: N4ZR4A10

RADIO SYSTEM

Safety symbols

Pay close attention to the following symbols and their meanings. Failure to follow these warnings could cause damage, injury or death.

	Attention	Not following these instructions may lead to minor injuries.
	Warning	Not following these instructions may lead to major injuries.
	Danger	Not following these instructions may lead to serious injuries or death.

Safety guide



Prohibited



Mandatory



- Do not use the product at night or in bad weather like rain or thunderstorm. It can cause erratic operation or loss of control.
- Do not use the product when visibility is limited.
- Do not use the product on rain or snow days. Any exposure to moisture (water or snow) may cause erratic operation or loss of control.
- Interference may cause loss of control. To ensure the safety of you and others, do not operate in the following places:
 - Near any site where other radio control activity may occur
 - Near power lines or communication broadcasting antennas
 - Near people or roads
 - On any body of water when passenger boats are present
- Do not use this product when you are tired, uncomfortable, or under the influence of alcohol or drugs. Doing so may cause serious injury to yourself or others.
- The 2.4GHz radio band is limited to line of sight. Always keep your model in sight as a large object can block the RF signal and lead to loss of control.
- Do not touch any part of the model that may generate heat during operation, or immediately after use. The engine, motor or speed control, may be very hot and can cause serious burns.



- Misuse of this product may lead to serious injury or death. To ensure the safety of you and your equipment, read this manual and follow the instructions.
- Make sure the product is properly installed in your model. Failure to do so may result in serious injury.
- Make sure to disconnect the receiver battery before turning off the transmitter. Failure to do so may lead to unintended operation and cause an accident.
- Ensure that all motors operate in the correct direction. If not, adjust the direction first.
- Make sure the model stays within the systems maximum range to prevent loss of control.

PRODUCT INTRODUCTION

Research Background

In the 1930s, German constructed the KdF Motor City in Wolfsburg, Lower Saxony, and registered the Gesellschaft zur Vorbereitung des Deutschen Volkswagens mbH, which later developed into the world-renowned Volkswagen headquarters and where the national car KdF-Wagen was produced.

KdF-Wagen, known as the people's car while none of which was sold to the people with all being requisitioned and converted into military vehicles, the most famous one of which is Kübelwagen. The Kübelwagen, which literally means "bucket car" and refers specifically to a light military open-top off-road vehicle, was developed in January 1938, featuring a low body and low weight, being easy to manufacture in large numbers, and cost-effective.

Construction Features

The prototype was developed on the basis of the People's Car KdF-Wagen chassis, model Typ62, with an air-cooled horizontally opposed four-cylinder engine and a rear-mounted rear-wheel drive layout. Although only rear-wheel drive was available, a limited-slip differential from ZF was used, greatly enhancing the ability to get out of trouble. The talented designer Dr. Ferdinand Porsche then continued to improve on this basis, adding wheel-side reducers to build a portal rear axle, and increasing the ground clearance of the chassis by 50mm to a staggering 310mm. In December 1939, two Typ82s rolled off the assembly line, underwent and successfully passed rigorous tests in Kummersdorf and Eisenach, and received its official name Pkw.K1 Typ82. It later became the most widely used and best-performing light off-road vehicle in the German army, and was loved by front line and soldiers. In late 1942, the U.S. Army acquired a Type 82 Kubelwagen, which was then tested at Aberdeen Proving Ground. Army automotive experts evaluated it as an excellent driving performance and good handling car with four-wheel independent suspension and an LSD limited slip differential on the rear axle, with off-road performance approaching that of a four-wheel drive vehicle. The actual test concluded that the bucket car was not as good as the Willys in terms of extrication in extreme terrain, but in most off-road conditions the Typ82 showed excellent driving performance as Willys, and better on-road driving performance and comfort than the Willys. In addition, the barrel weighs only 685kg and the 985cc engine can produce 23.5hp with half the fuel consumption of the Willys. In other words, the Germans used 60% of the raw materials to obtain tactical maneuverability close to that of the Americans. With no beams, a smooth chassis, extremely low unit pressure after installing desert tires, and an air-cooled engine that required even less water, the barrel car's off-road performance in the desert terrain of the North African battlefield far exceeded that of a 4WD. Later in the war the Germans were losing, and the U.S. Army had the opportunity to capture more intact Type82, and the barrel car's good performance was so popular with the U.S. Army that soldiers were even willing to trade two Willys for one Type82.

Type82 is rear-wheel drive, while Typ86 and Typ87 four-wheel drive, of which Typ86 is not mass-produced as the off-road performance of the Typ82 has been so excellent that increased performance four-wheel drive version brought was more than pay for itself considering the strained strategic resources. Moreover, its complex structure is also not conducive to wartime

production on a large scale, not to mention the maintenance burden brought to the logistics units. Therefore, the four-wheel drive structure was only used on the Typ87 and the amphibious Typ128/166, which had to use four-wheel drive.

About Mode

The FMS 1/12 Kübelwagen RC Model presents itself in Mid-term to take you back to the war-torn era with its spectacular design.

We start with engine. The Boxer air-cooled engine serves as the core of the car, an engine used in several later generations of classic cars and lasted 65 years in the Beetle, a saga that came to an end when the last Beetle, number 21,529,464, rolled off the production line in Puebla, Mexico, on July 30, 2003.

Initially the Typ82 used a 985cc engine, later upgraded to 1131cc, then gradually increased displacement, and in the [REDACTED] used a 1488cc engine, doubling the horsepower from the very beginning. The cylinders of the horizontally opposed engine are distributed on both sides, a 130 motor in the right cylinder position, and another 130 motor reserved for the left side, which can output twice as much power when applied to the [REDACTED] or [REDACTED] platform. The engine crankshaft flywheel is connected by a belt to drive the generator and the cooling fan as well. The semi-circular fan fairing is a major feature, in which the airflow is distributed to the cylinders on both sides. All is restored on the model, meaning you can observe the blades rotating through the fan intake when the motor is running. The Kübelwagen has 4 forward gears and the maximum speed of each gear respectively goes as 1st gear 18.4km/h; 2nd gear 32.4km/h; 3rd gear 54.2km/h; 4th gear 83.6km/h. The corresponding red line of gearshift tips is available on the dashboard. On the model, we designed a 2-speed shift to simulate the speed of the 1st and 3rd gears of the real car. The power crosses over from the top of the rear axle differential and then returns to the rear axle. The model share the same structure as the real engine, with the benefit of compactness, making it easy to switch between 4WD and RWD modes. This shift function is perfectly reproduced on the model to provide more driving pleasure when driving off-road.

Then let's move to chassis. The popular portal axle in today's crawler market has been in mass production for barrel car as early as 82 years ago, from which wheelside reducer reduction ratio of 15:21 has learned a lot, making the barrel car chassis minimum ground clearance of 310mm, dwarfing all modern off-road cars on the market today. On the real car, the front and rear wheel speeds are balanced by increasing the front axle differential gear ratio while on the model we set the door axle reduction ratio to 1:1 for common front and rear axle differentials.

Solid load-bearing chassis with stamped central ridge tube chassis and body bears high torsional resistance. The central drive shaft and electrical wiring are hidden in the ridge tube. The one piece injection model features the texture of metal stamping with plastic as location and size of each reinforcement are restored according to the actual car. The front and rear wheels adopt torsion-bar-springs independent suspension allowing long travel capability and little space occupation. We use torsion springs instead of torsion bar springs to present the front and rear suspension, Easy to disassemble and change tuning.

The car body, on which R&D team spend the most time where you can see the [REDACTED] horn and headlights, [REDACTED] camouflage lights. The tires are the most common 5.25x16 in the barrel car.

Like the real car, the simulated wheels need to be fixed with 5 screws, the spare tire on the front available for being taken off and installed for use. Remove the spare tire, the typical of the mid-cycle spare tire bracket is readily accessible. The windshield can be put down and fixed on the front bracket and the real rearview mirror's angle is adjustable like a real car.

The openable four doors are not worth mentioning but it would be much more interesting to find the structure that the doors could be opened and locked by turning the door handle. The comfortable seats have soft foam cushions even a little bit luxurious by 1939 standards.

The dashboard shows the speed and timing of gear changes with the current mileage 203 km, about the distance driven from the Wolfsburg factory to Berlin. No doubt we are selling a new car. To start this car, it is hard to find the switch but the user guide of the real car is available for you to find the start button in the lower left corner of the dashboard. Just press it through the steering wheel. A sweet gadget is also provided for your convenience. As FMS always did, the steering wheel and the wheel are linked. With 1/12 figures, a plot can be vividly displayed and users can gradually refine the plot with the increase of this series.

The armrest in front of the rear seats has four clips in the middle that fit into holes in the floor to hold four 98K rifles which were produced by the Mauser Arsenal in Oberndorf and needed to be purchased separately for 70 Reichsmark each at the 1939 exchange rate. The rear seatbacks could be lowered for easy access to supplies from the trunk. Great efforts have been made on optimizing the layout of the electronics to prevent the battery or receiver from taking up space in the trunk. The trunk height of the Typ82 was designed to accommodate 20L oil (water) Jerry can or to store weapons, ammunition, and food supplies. All these features are properly restored to make the user experience more fun, but of course, these supplies, like the 98K, had to be purchased separately.

For the electronic system, 4-channel digital proportional remote control system is applied. In addition to 1&2 channels for steering and throttle control, the 3rd channel controls the gearshift and the 4th channel switching between 4WD and RWD. There is also integrated light control, which allows you to turn on the headlights during normal night driving. Linked turn signals and brake lights are at the rear of the car. Users can only turn on the anti-aircraft lights during the night light restriction.

Then comes to the packaging, which used environmental friendly foam material to simulate the World War II German tin ammunition boxes. The recyclable box can bear long-distance transport easy to store, easy to carry.

Kübelwagen has a far-reaching impact on automobile history. Many famous hobby brands have repeatedly launched related products. So far, no one can do as well as us.

We here at FMS hope you enjoy the Kübelwagen Type 82 as much as we did in bringing it to life in the form of this classic piece of wartime history.

Ty82 Research Team
2021.9.29

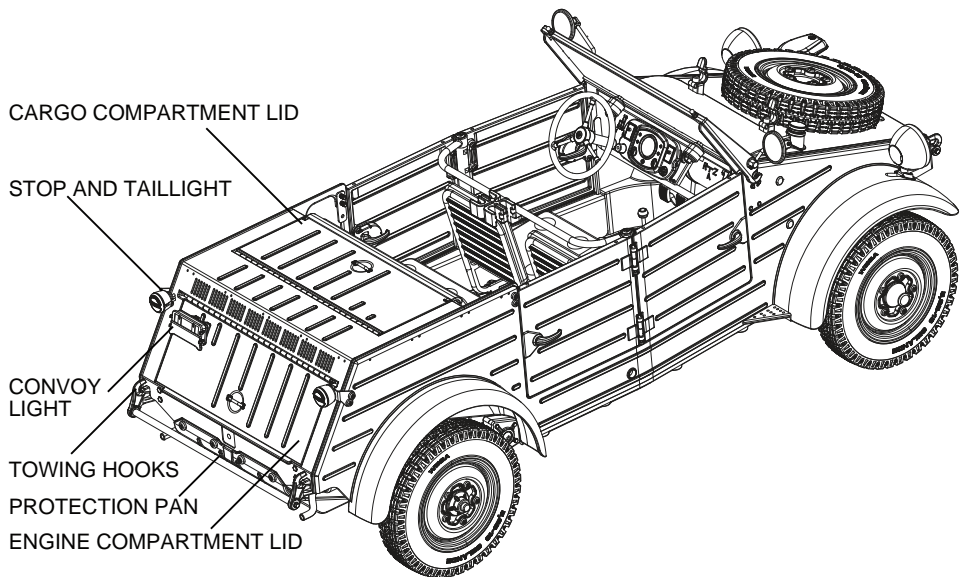
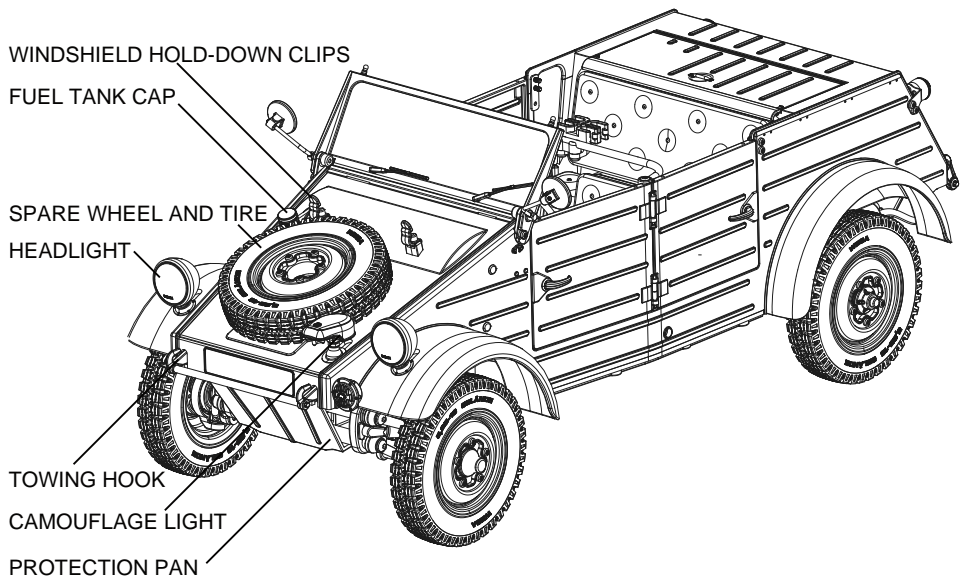

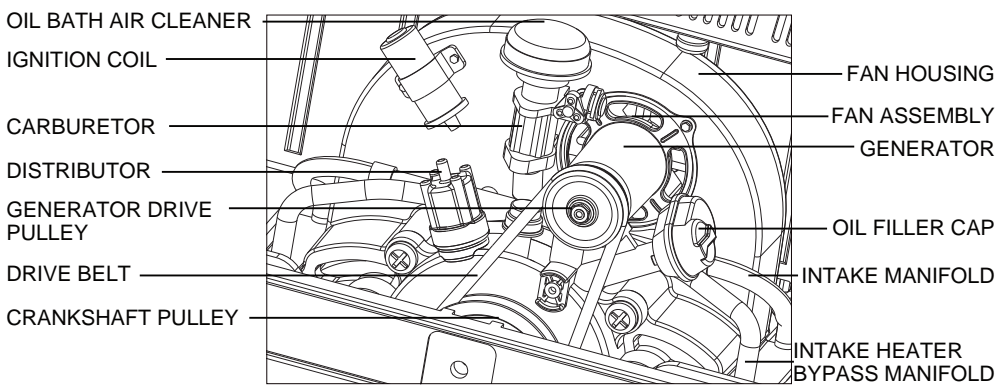
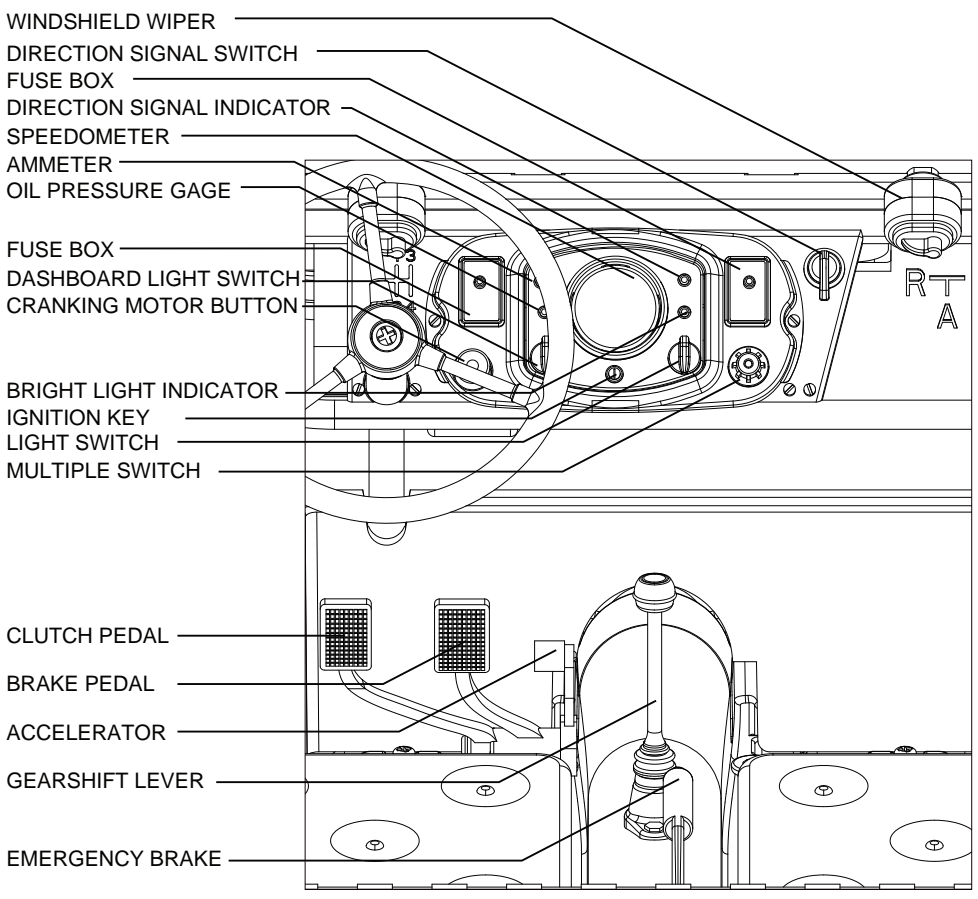

Transmitter instruction

Introduction

FS-R4A1 based on ANT protocol is a three-in-one receiver with ESC and LED light group control board. It has an external single antenna, can output PWM signal and light control signal, can implement two-way transmission, adopts automatic binding, and has a compact design, which can be adapted to various model cars.

Transmitter Overview

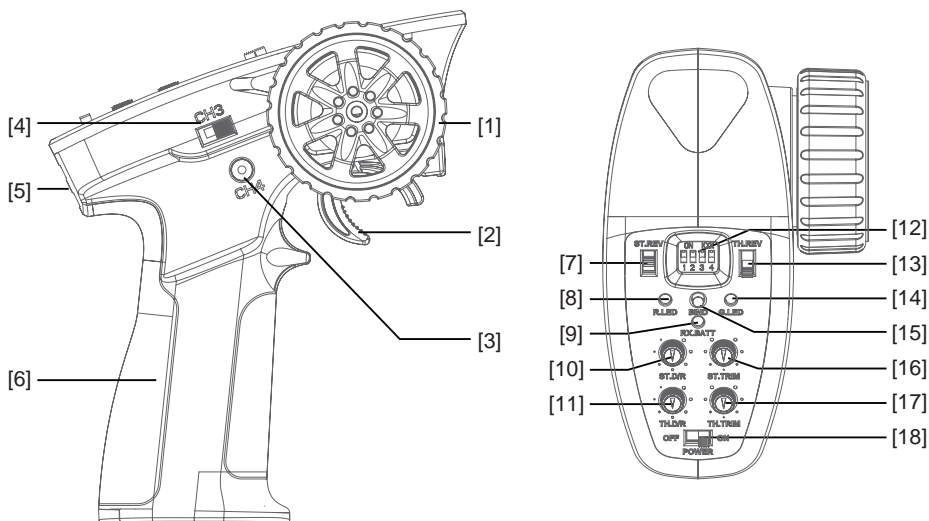

[1]	Traversing handwheel, 35 degrees on each side (CH1)	[10]	ST.D/R
[2]	Throttle button, 25 degrees in front and 12.5 degrees at rear (CH2)	[11]	TH.D/R
[3]	Push button switch (CH4) [Push button function is flip type]	[12]	Switch to the electric adjustment mode
[4]	Three-position toggle switch (CH3)	[13]	TH.REV
[5]	Lanyard hole	[14]	G.LED
[6]	Handle, 4*AAA battery compartment	[15]	BIND
[7]	ST.REV	[16]	ST.TRIM
[8]	R.LED	[17]	TH.TRIM
[9]	RX.BATT	[18]	Power Switch

Overview

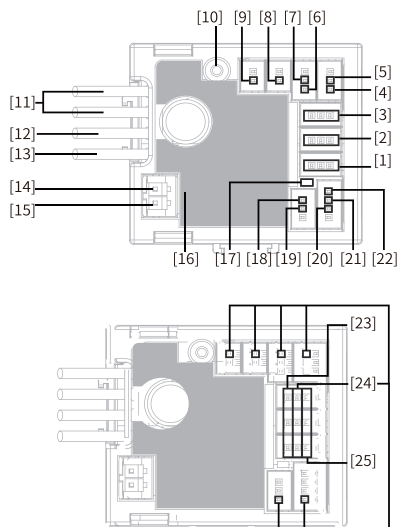

- | | |
|---------------------------|----------------------------|
| [1] CH1 | [14] Motor port "+" |
| [2] CH3 | [15] Motor port "-" |
| [3] CH4 | [16] Stickers |
| [4] Left-turn light port | [17] LED |
| [5] Head light port | [18] Left-turn light port |
| [6] Right-turn light port | [19] Right-turn light port |
| [7] Head light port | [20] Reversing light port |
| [8] Fog light port | [21] Brake light port |
| [9] Fog light port | [22] Taillight port |
| [10] Antenna | [23] Signal pin |
| [11] Power switch | [24] Power "+" |
| [12] Battery line "+" | [25] Power "-" |
| [13] Battery line "-" | |

Specifications

- Product Name: FS-R4A1
- Adaptive transmitter: FS-MG41
- Model Type: Car
- Channels: 4
- Numbers of Light Interfaces: 7
- RF: 2.4GHz ISM
- 2.4G Protocol: ANT
- Antenna: Single antenna
- Input Power: Lipo (2S)/NiMH (5~7Cell)
- BEC Output: 6V/1A
- Continuous/Peak Current: 10A/50A
- Data Output: PWM
- Temperature Range: -10°C—+60°C
- Humidity Limit: 20%~95%
- WaterProof: PPX4
- Online Update: No
- Dimensions: 33mm*30mm*12mm
- Weight: About 11g
- Certification: CE, FCC ID: N4ZR4A10

Binding

The receiver automatically enters the binding state once it is powered on.

Press the **BIND** Key to turn on the transmitter and allow it to enter its binding state. Here, **G.LED** flashes quickly, and operator releases the **BIND** Key.

1. When the receiver is powered on and waits for 1 second, it will automatically enter the binding state if it is not connected;
2. After the binding is successful, the LED indicator of the receiver is always on.

Notes: (1) Set the transmitter to its binding state first, and then set the receiver to its binding state. If the binding is not completed within 10s, the indicator light of the receiver will enter its slow flashing state. (2) If re-binding is successful, all the settings of the car lights will be restored to their default values.

ESC protection

This receiver has multiple prompt functions such as power-on self-check display, overheating alarm prompt, and low/high voltage alarm prompt.

- Self-check display: all car lights will be on for 1S when the receiver is powered on;
- Overheating alarm: When the internal temperature of the ESC is detected to exceed 110°C ,motor has no output, all car lights flash promptly, and the normal output will be restored when the temperature is lower than 70°C;
- Low/high voltage alarm: When the receiver enters the low voltage protection, motor has no output, and all the lights flash slowly; when the receiver enters the high voltage protection, all channels have no output. All car lights flash promptly.

ESC function instructions

1.Connect related equipment:

Make sure the ESC is off before connection.Connect the motor with M+ and M- of ESC. Connect the steering servo to the 3Pin interface marked with "ST" of ESC (- + S connected correspondingly).Connect the battery with the positive and negative poles of ESC correspondingly.

2. Normal boot, identification throttle midpoint:

After connecting related equipment as step 1, turn on the radio first, move the throttle trigger to the neutral position. Turn on the switch of ESC at last. The receiver will automatically recognize the battery type when it is powered on again. Then it can run it.

Notes:

- a. The ESC can be run after completing self-inspection (about 3 seconds) if power on, otherwise it cannot be operated normally.
- b. If there is no power output and the red light of ESC flashes quickly after power on, please check whether the throttle trim of the transmitter is set to the "0" position, the receiver will automatically recognize the midpoint of the trim throttle after restarting;
- c. If the rotation direction is not correct during running, exchange the two wires connecting motor and ESC.
- d. To make sure everything is ok, please turn on the transmitter first and finally turn on the ESC, turn off the ESC first and finally turn off the transmitter.

Notes: Please refer to the relevant sections for details about the battery type, drag brake force and running mode of the ESC.









Failsafe

This function is used to protect the safety of the model and the operator when the receiver cannot normally receive the signal from the transmitter and is out of control. The receiver defaults that the throttle channel is fixed to be out of control and enters the brake state. After other channels are out of control, the receiver has no signal output. If you set it on the transmitter, it will output according to the set value.

Attention:

- Make sure the product is installed and calibrated correctly, failure to do so may result in serious injury.
- Please carefully check each power device and car frame instructions to ensure the power matching is reasonable before use. Avoid damaging power system due to incorrect matching.
- Do not let the external temperature of the system exceed 90°C / 194°F, because high temperature will damage the power system.
- Make sure the receiver's battery is disconnected before turning off the transmitter, failure to do so may lead to unintended operation or loss of control.
- After use, remember to disconnect the battery and the ESC. If the battery isn't disconnected, the ESC will consume electric energy all the time even if it is off. It will discharge completely if connect the battery for a long time, thus resulting in the failure of the battery or the ESC. We are not responsible for any damage caused by this!
- Make sure the receiver is mounted away from motors or any device that emits excessive electrical noise.
- Keep the antenna of the receiver at least 1cm away from conductive materials such as carbon or metal.
- Do not power on the receiver during the setup process to prevent loss of control.

ESC Parameter Setting

Running Mode	Battery Type	Drag Brake	
 FWD/REV/BRK	 Lipo	 0%	 75%
 FWD/REV	 NiMH	 50%	 100%

Dial Switch sign

The Dial Switch on the transmitter is used to set ESC parameters, that is, the Dial Switch is located at different positions and the corresponding parameter values are different.

Setting Method:

There are three parameters can be set for the ESC, which are "Running mode", "Battery type", "Drag brake", There are slide switches numbered 1 2 3 4 on the radio panel . The above parameters can be set by dialing down and up. The specific operation is as follows:

When No. 1 slide switch is on the down, it indicates that the operation mode is set to FWD / REV / BRK.

When No. 1 slide switch is on the up, it indicates that the operation mode is set to FWD/REV.

When No. 2 slide switch is on the down, it indicates that the battery type is set to Lipo.

When No. 2 slide switch is on the up, it indicates that the battery type is set to NiMH.

When No. 3 and No.4 slide switch are on the down, it indicates that the drag brake force is set to 0%.

When No. 3 slide switch is on the down and No.4 slide switch is on the up, it indicates that the drag brake force is set to 50%.

When No. 3 slide switch is on the up and No.4 slide switch is on the down, it indicates that the drag brake force is set to 75%.

When No. 3 and No.4 slide switch are on the up, it indicates that the drag brake force is set to 100%.

Parameter Explanation:**1. Running Mode**

FWD/REV/BRK: This mode adopts "double click" reverse mode, that is, when the throttle trigger is pushed from neutral range to the reverse area for the first time, the motor is only braking and will not reverse; when the throttle trigger is moved back to the neutral range and pushed to the reverse area for the second time, it will reverse. This mode is applicable to general models.

FWD/REV: This mode adopts "one click" reverse mode, that is, when the throttle trigger is pushed from neutral range to the reverse area, the motor immediately generates reverse action, which is generally applied to rock crawler.

Parameter setting method:

When No. 1 slide switch is on the down, it indicates that the operation mode is set to FWD / REV / BRK.

When No. 1 slide switch is on the up, it indicates that the operation mode is set to FWD/REV.

2. Battery Type

There are LiPo and NiMH cells. The low-pressure protection value is different under different types. It can be set according to the actual use.

Parameter setting method:

When No. 2 slide switch is on the down, it indicates that the battery type is set to Lipo.

When No. 2 slide switch is on the up, it indicates that the battery type is set to NiMH.

3. Drag Brake Force

The drag brake means that when the throttle trigger moves from the forward or reverse area to neutral range, it will produce certain braking force to the motor, the larger the value is, the greater the drag brake force is. Select proper braking force according to the actual situation.

Parameter setting method:

When No. 3 and No.4 slide switch are on the down, it indicates that the drag brake force is set to 0%.

When No. 3 slide switch is on the down and No.4 slide switch is on the up, it indicates that the drag brake force is set to 50%.

When No. 3 slide switch is on the up and No.4 slide switch is on the down, it indicates that the drag brake force is set to 75%.

When No. 3 and No.4 slide switch are on the up, it indicates that the drag brake force is set to 100%.







Lighting function

				Times for Pressing						
Button	Light Position	Function	Power on is off by default	I	II	III	IV	V	Control Mod	Remarks
CH4	Headlight	White headlights keep on		OFF	•	OFF	OFF	OFF		
		White headlights keep on with high brightness		OFF	OFF	•	•	OFF		
	Taillights	Taillights keep on		OFF	•	•	•	OFF		
		Taillights turn red with high brightness amid brake operation		○	○	○	○	○	Throttle linkage control	Brake lights are on with high brightness amid brake operation
	Fog lamp	The yellow headlights keep on		OFF	OFF	OFF	•	•		
	Turn Signal	Left turn yellow light		OFF	○	○	○	○	Direction linkage controlL	3 left turn signals automatically blink in the left turn with a 1-sec flashing frequency, namely on 0.5 sec and off 0.5 sec.
		Right turn yellow light		OFF	○	○	○	○	Direction linkage control	3 right turn signals automatically blink in the right turn with a 1-sec flashing frequency, namely on 0.5 sec and off 0.5 sec.
		The brake lights show double flash in the left and right turn.		OFF	OFF	OFF	•	OFF		A total of 6 left and right turn signals flash automatically regardless of direction with a 1-sec flashing frequency, namely on 0.5 sec and off 0.5 sec.

Getting started

Before operation, install the battery and connect the system as instructed below.

★ Transmitter Battery Installation

 Danger	Only use specified battery (X4 AA batteries).
 Danger	Do not open, disassemble, or attempt to repair the battery.
 Danger	Do not crush/puncture the battery, or short the external contacts.
 Danger	Do not expose to excessive heat or liquids.
 Danger	Do not drop the battery or expose to strong shocks or vibrations.
 Danger	Always store the battery in a cool, dry place.
 Danger	Do not use the battery if damaged.

Battery Type: AAA

Battery Installation:

1. Open the battery compartment cover.
2. Insert 4 fully-charged AAA batteries into the compartment. Make sure that the battery makes good contact with the battery compartment's contacts.
3. Replace battery compartment cover.

Low battery alarm: When the battery is lower than 4.2V, the LED on the panel will flash slowly.

Instructions

After setting up, follow the instructions below to operate the system.

1. Automatic code matching (the transmitter and receiver have been successfully coded before leaving the factory.)

If you need to replace another transmitter or receiver, please follow the following steps to code:

1. When the transmitter power is on and the code matching mode is on, the light keeps flashing;
2. The power supply of the receiving board is turned on, and the front lights keep flashing to enter the code matching mode;
3. When the code matching is successful, all the transmitter lights are on and all the lights on the car are off;

Note: when code matching, please operate the transmitter to enter the code matching state first, and then operate the receiver to enter the code matching state.

THROTTLE STICK POSITION

Throttle stick position

Neutral point



Top point of forward direction

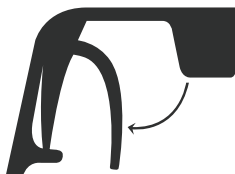

Top point of backward direction



VEHICLE SETUP

Connecting the battery

Step 1: open the hood.

Step 2: place the battery in the battery box and connect the battery plug.

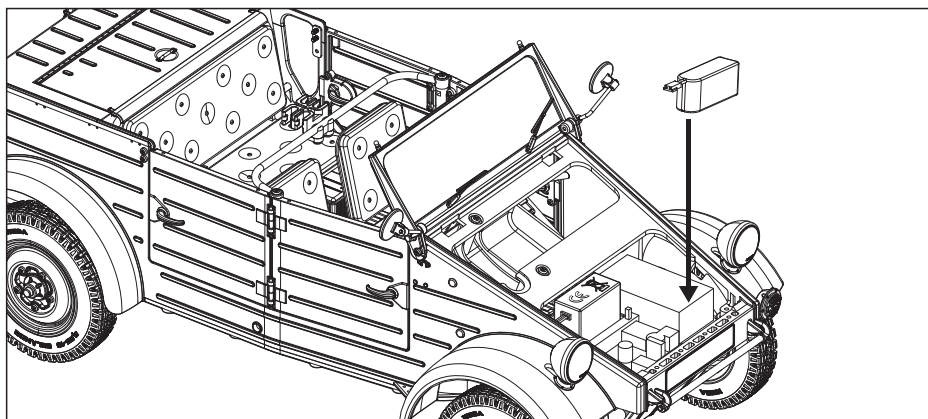

NOTE

- 1.If it is not in use for a long time, unplug and take off the battery to prevent battery leakage.
- 2.Do not open, disassemble, or attempt to repair the battery.
- 3.After use unplug battery from vehicle.Do not charge battery in vehicle.

OPERATING THE VEHICLE

Step 1: turn on the transmitter, the headlamp of the transmitter will flash and enter the frequency matching mode.

Step 2: turn on the receiver switch, the headlight will flash and enter the frequency matching mode.

Step 3: when the transmitter and receiver are successful in frequency up, the front lights of the transmitter will be on for a long time, and the front lights of the vehicle will be off.

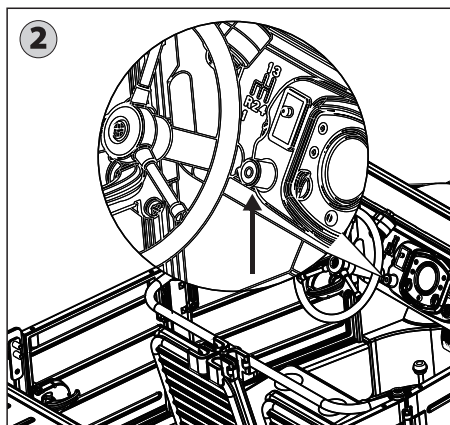
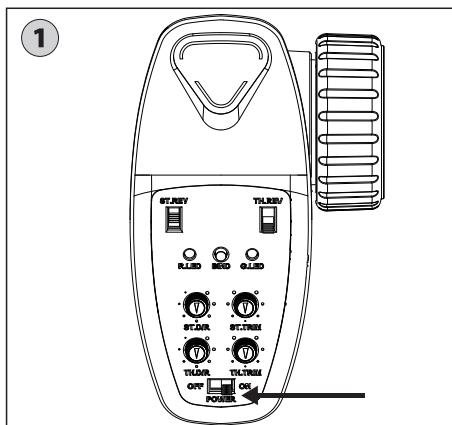

Standard Precautions for Type82 Kubelwagen

- The Type82 Kubelwagen was a vehicle with a high reputation in the history of automotive development, featuring many design firsts. This perfectly replicated model restores the charm of the original full-size car and features a large number of parts to complete the finished model. With assembly being complex it is impossible to set standards for all parts one by one, improper use may lead to model damage, so the following additional precautions are prepared along with the manual. Please refer to it if needed.

- Like the real car, the front windshield is properly fixed on the front two snaps. If you wish to erect the windshield, please lightly push this snap forward; otherwise, the windshield can be easily damaged.



- When erecting the windshield, there is slight interference between the windshield fixing hook and the door (at the dot), in this case please lightly press the door inward so you can erect the windshield smoothly; otherwise, there is a risk of damaging the windshield.



- Grasp the spare tire and use a little force to push upwards to open the front cover.



- The front cover is not hinged and can be completely separated, but there is a set of wires inside to power the anti-aircraft lights. Attention please when opening the cover.

- The anti-aircraft light brightness is set with reference to the actual car, meeting the minimum lighting requirements under light control conditions. Hence it's normal to have low brightness.

The front cover may have a gap of unequal spacing within 0.6mm. This is normal.



- Type82 Kubelwagen uses swing axle independent suspension, namely torsion springs are adopted instead of torsion bars as the elastic element. If torsion springs are too hard when holding up car weight, the cars movement will be extremely bouncy and in this case will not act like the real car. Hence, we selected soft and tight torsion springs to ensure a better driving performance, but also to lead to the front and rear suspension not rebounding at rest, which is normal.

- The real car's maximum ground clearance is 310mm (scaling ratio 25.8mm). To meet the performance requirements of RC off-road and considering the extra weight of figures, the maximum ground clearance set in the model is 30mm for no-load and 25mm for full-load, which can present a more simulated driving posture under different load conditions.

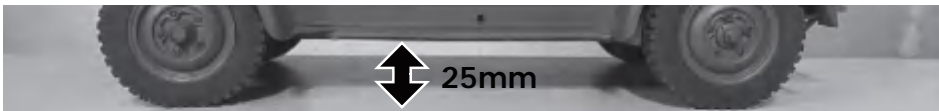
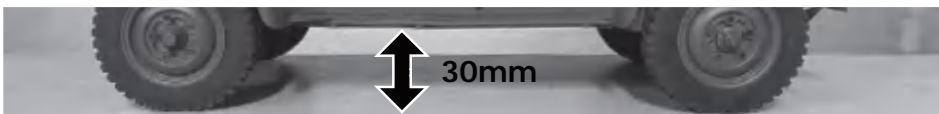

DISTRIBUTOR

North America:

Horizon Hobby LLC

2904 Research Road

Champaign, IL 61822, USA

Tel.: 217-403-3584

Sweden:

Minicars Hobby Distribution AB

Annelundsgatan 17C

749 40 Enköping, Sweden

Tel.: +46-171-14 30 02

The United Kingdom:

CML Distribution Ltd

Saxon House, Saxon Business Park, Hanbury Road

Bromsgrove, Worcestershire

B60 4AD, England

Tel.: +44 (0)1527 575349

Australia:

Model Engines Pty Ltd

Unit 1/32 Bluett Drive

Smeaton Grange

NSW 2567 Australia

Tel.: +61(0)411128284